



XPert® TXE™ Equipment Enclosures



XPert® TXE™ Equipment Enclosure is designed to address the needs of pharmaceutical research and quality control laboratories. It provides a safe, ventilated space for keeping powder-generating apparatus contained. Its tall 42" interior height accommodates equipment such as pill presses, grinders, crushers and sieves. HEPA-filtered air is returned to the laboratory.

Features & Benefits:

- Patented* rear baffle with zones of perforations promotes horizontal laminar airflow. The baffle sections pivot down or may be removed for cleaning.
- Interior height of 42" (107 cm) accommodates tall equipment such as pill presses, grinders, crushers and sieves.



- Built-in impeller with speed control and vibration-isolation supports. Blower has 40% reserve capacity to overcome filter loading.
- HEPA exhaust filter, 99.99% efficient, traps particles 0.3 micron in size so that clean air returns to the laboratory.
- True bag-in/bag-out filter disposal system.
- Static-dissipative and durable epoxy-coated metal exterior, stainless steel interior sides and integral work surface, and safety glass doors.
- Pre-wired fluorescent lamp and separate switches for blower and light.
- Two adjustable height doors of 1/4" (0.6 cm) thick tempered safety glass (see photo at bottom left). Door hinges are reversible to accommodate right or left side placement. Magnets keep doors securely closed.

All models conform to the following regulations and standards:

- SEFA 1-2005
- Modified ASHRAE 110-95
- ANSI Z9.5-2003
- UL 3101-1/61010-1
- CAN/CSA C22.2 No. 1010.1
- CE Conformity Marking (230 volt models)

Models with Guardian Airflow Monitor include:

- Guardian Airflow Monitor that continuously monitors airflow with a green LED that glows when airflow is within set point range and a red LED that glows and an audible alarm that sounds when airflow is outside set point range.

*U.S. Patent No. 6461,233

Exclusive feature



XPert TXE Equipment Enclosure 3890002 includes the Guardian 1000 Digital Airflow Monitor. The enclosure is shown atop Telescoping Base Stand 3746715.

Models with Guardian 1000 Digital Airflow Monitor include:

- Guardian 1000 Digital Airflow Monitor that continuously monitors airflow and provides a digital readout of actual face velocity. An audible/visual alarm alerts the operator when airflow is outside set point range. RS232 communications port allows connection to user-supplied computer.

All models require (not included):

- Supporting base.



Protecting your
laboratory environment
LABCONCO

XPert® TXE™ Equipment Enclosures

Nominal Width	Catalog Number	Overall Dimensions	Interior Dimensions	Electrical Requirements	Built-In Airflow Monitor	Shipping Weight lbs./kg
2'	3892000	24.0" w x 31.0" d x 56.9" h (61.0 x 78.7 x 144.5 cm)	22.6" w x 26.1" d x 42.0" h (57.4 x 66.3 x 106.7 cm)	115 volts, 60 Hz	None	250/113
2'	3892001	24.0" w x 31.0" d x 56.9" h (61.0 x 78.7 x 144.5 cm)	22.6" w x 26.1" d x 42.0" h (57.4 x 66.3 x 106.7 cm)	115 volts, 60 Hz	Guardian	250/113
2'	3892002	24.0" w x 31.0" d x 56.9" h (61.0 x 78.7 x 144.5 cm)	22.6" w x 26.1" d x 42.0" h (57.4 x 66.3 x 106.7 cm)	115 volts, 60 Hz	Guardian 1000 Digital	250/113
2'	3892020*	24.0" w x 31.0" d x 56.9" h (61.0 x 78.7 x 144.5 cm)	22.6" w x 26.1" d x 42.0" h (57.4 x 66.3 x 106.7 cm)	230 volts, 50 Hz no plug	None	250/113
2'	3892021*	24.0" w x 31.0" d x 56.9" h (61.0 x 78.7 x 144.5 cm)	22.6" w x 26.1" d x 42.0" h (57.4 x 66.3 x 106.7 cm)	230 volts, 50 Hz no plug	Guardian	250/113
2'	3892022*	24.0" w x 31.0" d x 56.9" h (61.0 x 78.7 x 144.5 cm)	22.6" w x 26.1" d x 42.0" h (57.4 x 66.3 x 106.7 cm)	230 volts, 50 Hz no plug	Guardian 1000 Digital	250/113

Dimensional Data

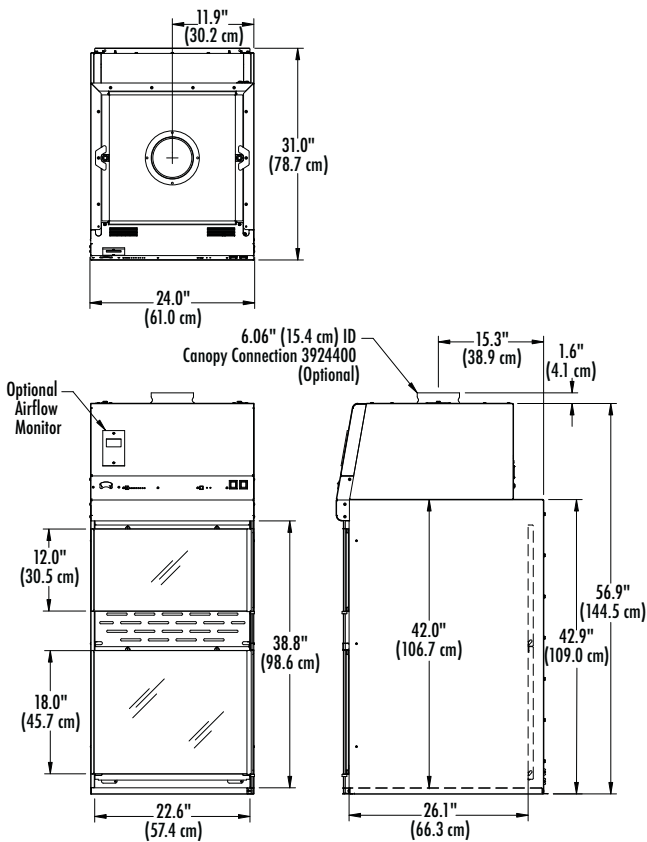

Telescoping Base Stands

Support XPert TXE Equipment Enclosures. Epoxy-coated 1.75" (4.4 cm) tubular steel. Adjustable to eight height positions at installation in 1" (2.5 cm) increments from 27.5" (70 cm) to 34.5" (88 cm). Available with fixed feet or 5" (13 cm) diameter casters. Shipping weight 100 lbs. (45 kg)

Telescoping Base Stands

Catalog Number	Overall Width X Depth	Description
3746715	24.0" w x 29.9" d (61.0 x 75.9 cm)	With leveling feet
3746716	25.2" w x 33.8" d (64.0 x 192.8 cm)	With toe-locking casters

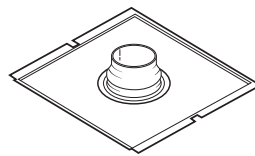

3924400 Canopy Connection

Allows the XPert TXE Equipment Enclosure to be thimble-ducted to the outside for additional protection. The canopy's air gap provides a means of balancing air by allowing room air to enter the ductwork and mix with the filtered air being exhausted from the XPert Enclosure. **House exhaust or remote blower is required (not included).** Shipping weight 15 lbs. (7 kg)

Contact Labconco for ordering information on remote blowers and ductwork.



Labconco Corporation
8811 Prospect Avenue
Kansas City, MO 64132-2696

800-821-5525 • 816-333-8811
FAX 816-363-0130
www.labconco.com

