

WaterPro[®] RO Stations

INSTRUCTION MANUAL

Models 90750-00, 90750-02

Product designs are subject to change without notice

© 2002 Labconco Corporation

90873 Revision I / ECO B402

Printed in U.S.A.

TABLE OF CONTENTS

Introduction

Components Shipped	1
General Description	2
Performance	3
Flow Chart	4
Component Identification	5-6

Specification

RO Specifications	7
Inlet Water Specifications	7
Environmental Conditions	8

Installation

Preparation	9
Inspection	9
Installation	9
Electronic Connection	9
Feed Water Requirement	9
Location	10
Feed Water Connection	10
Tubing Installation	10
Utility Connections	11
Optional Dispense Gun Installation	12
RO Membrane Installation	13-14
WaterPro PS and Glassware Washer	15

Safety Precautions.....16

Normal Operation

Electronic Control	17
Initial Start Up	18
Automatic Flush Valve	18
Work Techniques	19
Shut Down	19
Start-Up	19

Maintenance20

TABLE OF CONTENTS

Decontamination/Cleaning

Sanitization	21
Inorganic Fouling.....	22
Procedure	22
Organic Fouling	23
Preserving RO Membrane.....	23

Service

Front Panel Removal.....	24
Prefilter and Carbon/Prefilter Replacement.....	24
Air Vent Filter Replacement.....	24

Expendables	25
--------------------------	----

Replacement Parts	26-27
--------------------------------	-------

Dimensions	28
-------------------------	----

RO Production Rates Table	29
--	----

Wiring Diagrams	30-31
------------------------------	-------

Troubleshooting	32-33
------------------------------	-------

Warranty	34
-----------------------	----

Operating Log Sheet	35
----------------------------------	----

Shipping Claims	36
------------------------------	----

Accessories	37
--------------------------	----

Contacting Labconco	38
----------------------------------	----

Components Shipped

Carefully check the contents of the carton for damage that might have occurred in transit. Do not discard the carton or packaging material until all components have been checked against the following list and the equipment has been installed and tested.

As shipped, the carton should contain the following:

<u>Part Number</u>	<u>Description</u>
90750-00	115V WaterPro RO Station – wall mounted
or	
90750-02	230V WaterPro RO Station – wall mounted
90873-00	Manual, RO
90447-00	Spanner wrench
91082-00	Template
10503-06	Guide to Laboratory Water Purification
1305800	115V Power Cord
or	
1305900	230V Power Cord
9081500	Water Test Kit Request Card
9013415	Tube, Parflex 3/8" O.D. x 1/4" I.D. x 60"
1895320	Tapping Screw, Wall Mount 1/4-14 x 1-1/4" Lg

INTRODUCTION

General Description

The Labconco WaterPro RO Stations, models 90750-00 and 90750-02 produce reverse osmosis water upon demand. The units are equipped with a 17-liter storage tank as standard.

The unit may be interfaced with a Labconco WaterPro PS Polishing Station to directly feed the Polishing Station with RO purified water. The unit may also be connected to a Labconco Glassware Washer to dispense RO purified water for the final rinse cycle of the water.

An optional dispensing gun kit is available to allow easy installation in the field. The dispense gun has a 6 foot hose for remote dispensing.

The units are designed to be wall mounted. An optional stand, Catalog #90774-00, converts the wall-hung unit for bench mounting.

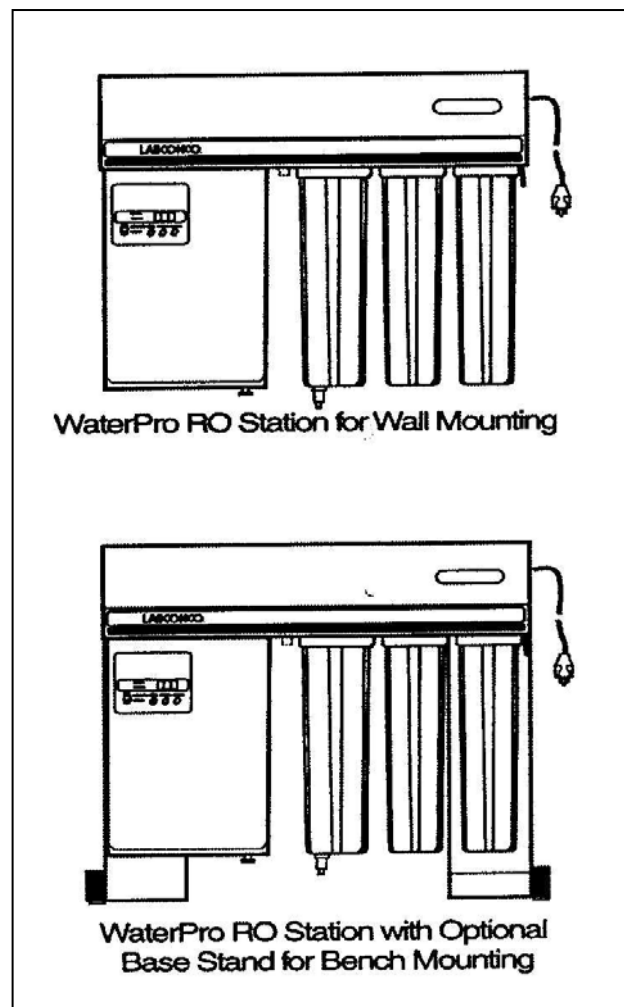

Figure 1

Performance

Labconco's WaterPro RO Station dispenses reverse osmosis purified water at the rate of up to 1 liter per minute at 25°C from either the manual dispense valve or the optional dispensing gun. Water from the dispense valve may also be activated automatically by using the timed dispense feature that allows dispensing of the water for a period up to 99.9 minutes. An outlet port from the 17-liter storage tank is provided for connection to a WaterPro PS Polishing Station and/or a Labconco Glassware Washer.

The unit accepts softened or tap feed water. Softened water is preferred for extended membrane life. Softened water is required when the LSI (Langlier Saturation Index) is positive. This is determined through the Water Profile testing service from Labconco. Each model has the capability of displaying water quality in microsiemens μS , water temperature in °C, timed dispense duration from 0 – 99.9 minutes and a storage tank full indication light. The RO Station includes built in activated carbon and particulate prefilters prior to the reverse osmosis membrane and storage.

The WaterPro RO Station is preset to 150 psi operating backpressure to provide an optimal RO membrane conversion rate, prolonging membrane life.

To reduce bacterial growth in the storage tank, an automatic flush valve is incorporated to automatically flush the storage tank while flushing the RO membrane for 3 minutes every 12-hour period of inactivity. This process is controlled by the microprocessor board.

A hydrophobic filter is installed above the storage tank to filter air entering the tank as the tank empties.

A 70-liter tank with or without a dispensing gun, and pump is available in addition to the standard 17-liter storage when greater quantities of RO water are required.

Figure 2 shows the flow diagram of the WaterPro RO Station.

INTRODUCTION

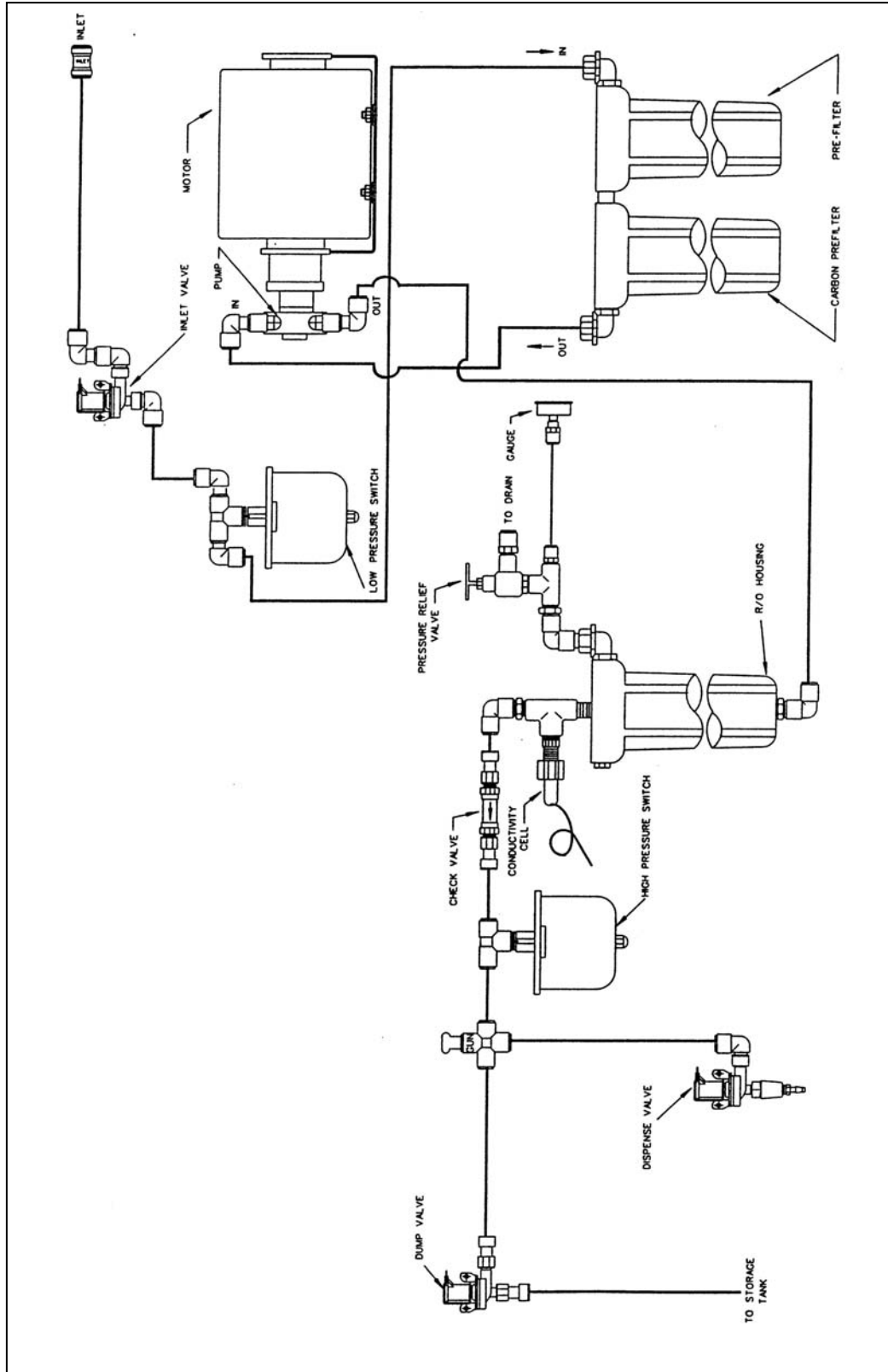

Figure 2

Component Identification (Refer to Figure 3)

1. **Control Panel.** The control panel located on the left side of the unit contains the PC board.
2. **ON/OFF Switch.** The ON/OFF switch activates the display.
3. **Pressure Gauge.** The pressure gauge indicates the RO back pressure. It is preset to 150 psi. **Do not increase or decrease the pressure.**
4. **Air Vent Filter.** The air vent filter introduces bacteria-free air into the reservoir.
5. **Inlet Valve.** The inlet valve allows feed water to enter the system.
6. **Conductivity Sensor.** The conductivity sensor transmits conductivity readings of the permeate (RO purified water) to the PC board.
7. **Pressure Switch.** The pressure switch shuts down the unit when the pressure in the system reaches approximately 40 psi.
8. **Rotary Vane Pump.** The rotary vane pump boosts the pressure to the RO.
9. **Low Pressure Switch.** The low-pressure switch senses low inlet pressure and shuts off the pump to prevent pump damage.
10. **Flush Valve.** The flush valve opens to flush the membrane and storage tank after 12 hours of inactivity.
11. **Dispensing Valve.** Manual dispensing valve dispenses RO water when the valve is open and automatic timed dispense when timed dispense selected.
12. **Check Valve.** The check valve installed in the RO housing prevents damage to the membrane due to permeate backpressure.
13. **Dispensing Outlet Port.** This port allows the unit to be connected to other equipment (such as a polishing station or glassware washer).
14. **Inlet Water Fitting.** Connects to feed water supply.
15. **Storage Tank.** Provides storage for 17 liters of RO purified water.
16. **Pump Motor.** ¼ HP motor drives the rotary vane pump.
17. **Float Switch.** Turns unit off when 17-liter tank is full.
18. **Storage Tank Cover.** Removable to expose storage tank.
19. **Back Pressure Relief Valve.** Provides constant back-pressure across the membrane.

INTRODUCTION

Component Identification

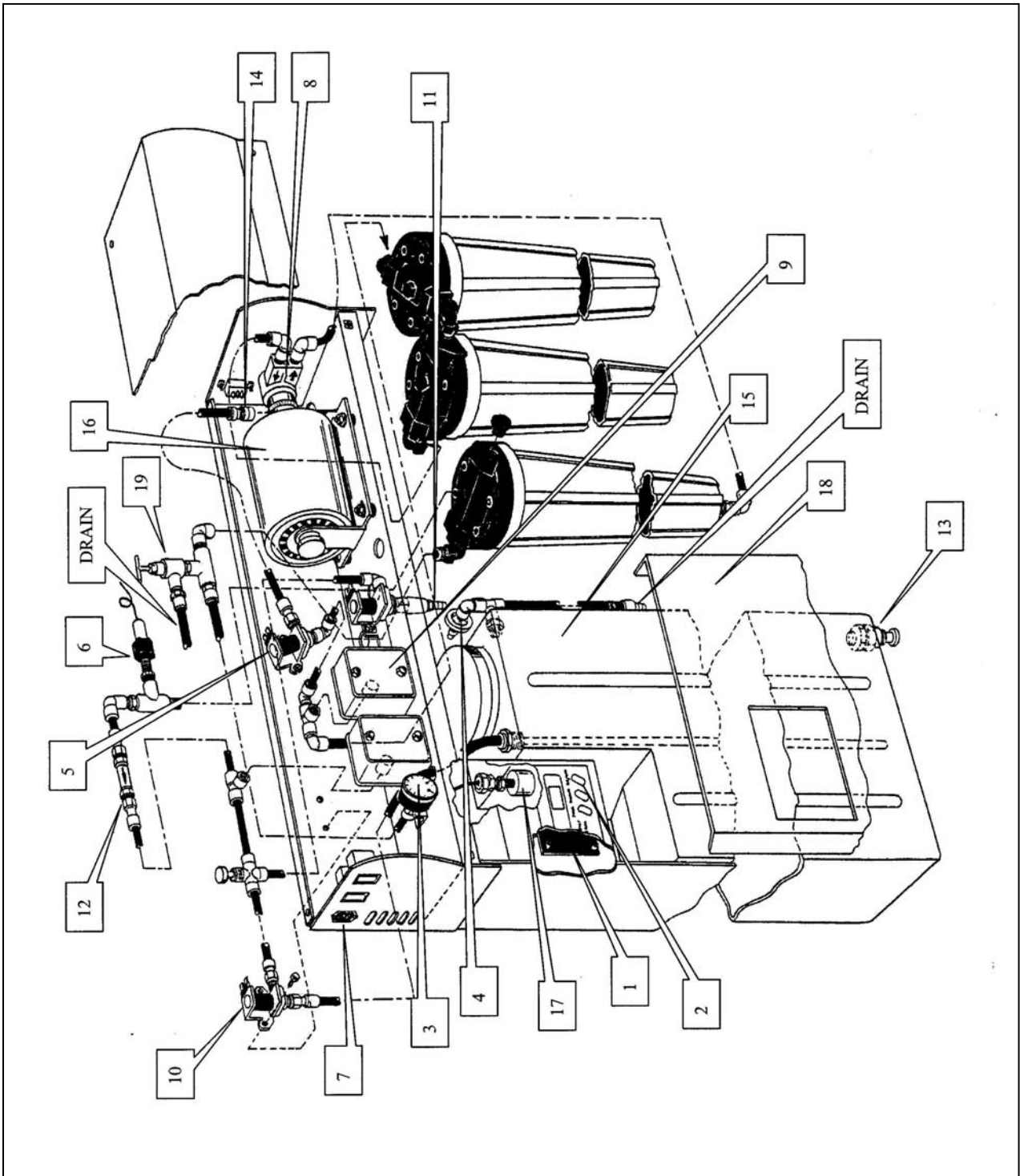

SPECIFICATIONS

RO SPECIFICATIONS:

Technology:	Reverse Osmosis
Reverse Osmosis Membrane:	Polyamide thin film composite membrane
Minimum Rejection Rate:	94%
Maximum Pressure Drop per Element	6 psig
Relative Humidity:	Less than 80%
Water Dispensing System:	Manual dispensing when automatic timed dispense is not selected. Timed dispense 0 – 99.9 minutes.
RO Water Production Rate:	Port for WaterPro PS and/or Steam-Scrubber Glassware Washer connection. From RO: Up to 1 L/min. (at 25°C) 8.7 L/min. typical flow (gravity) from storage tank.
Optional Storage Tanks:	70 liter with or without pump and dispensing gun. (91000-00 & 91000-01, 91010-00 & 91010-01)
Electrical Requirements:	115V, 60 Hz, 7.5 Amps or 230V, 50 Hz, 4 amps. 115V, 60 Hz, 12 amps or 230V, 50 Hz, 6 amps when WaterPro RO is electrically connected to a WaterPro PS Polishing Station.

INLET WATER SPECIFICATIONS:

Temperature:	5° - 40° C 41° - 104° Fahrenheit
pH:	4 – 10
Water Pressure and Flow:	30 – 100 psi (2-7 bar) 1.6 gallons/min (6 liters/min) at a minimum pressure of 30 psi
Maximum Silt Density Index:	5 SDI
Turbidity:	≤ 1 NTU
Langlier Saturation Index*:	Negative (if positive, requires water softener pretreatment)

*LSI is indicated in the Water Profile water analysis test treatment. Recommendations will be provided by Labconco.

SPECIFICATIONS

Maximum Ion Concentrations:

Iron (Total):	0.1 ppm (mg/L)
Manganese	0.1 ppm
Free Chlorine:	0.5 ppm

Environmental Conditions:

This equipment is designed to be safe under the following conditions:

- Indoor use.
- Altitude up to 6562 Ft. (2000 m).
- Maximum relative humidity 80% for temperatures up to 88°F (31°C) decreasing linearly to 50% relative humidity at 104°F (40°C).
- Main supply voltage fluctuations not to exceed $\pm 10\%$ of the nominal voltage.
- Transient over-voltages according to Installation Categories II (Over-Voltage Categories per IEC 1010).
- Pollution degrees 2 normally only non-conductive foreign matter, solid, liquid, or gaseous (ionized gases), that may produce a reduction of dielectric strength or surface resistivity occurs. Occasionally, however, a temporary conductivity caused by condensation must be expected, in accordance with IEC 664.

Preparation

The WaterPro RO Station should be located adjacent to appropriate electrical, feed water and drain connections. There are two gravity drain lines, one from the overflow tank and one from the RO. **The floor drains must be located below the exit points of the WaterPro RO Station.** When mounting next to a WaterPro PS Polishing Station use the optional electrical connection cord, part number 13060-00. This cord conveniently connects the RO to a PS.

Do not remove the RO Station from its carton until it is ready to be placed in its final location. If your feed water was not tested by Labconco prior to purchase of the WaterPro RO Station, call Labconco at (800) 821-5525 or (816) 333-8811, or return the business reply card to obtain a Water Profile test kit. Pretreatment of the feed water, if required, will be recommended after analysis.

Inspection

Your WaterPro RO has been fully tested and inspected prior to shipment. Inspect your unit thoroughly at the time of receiving shipment, and report any damage that may have occurred in transit immediately to your freight carrier.

Installation

Unfold the installation template included and follow the instructions listed on it to prepare the surface for mounting. If the optional support stand or optional WaterPro RO/PS Mobile Stand has been purchased, discard the templates and follow instructions provided with the stands.

Electrical Connection

Your 115V WaterPro RO Station comes fully wired with electrical cord, and plug to connect to a standard outlet. The 230V unit comes fully wired with electrical cord, but without plug. The electrical outlet should be rated at 115 VAC, 60 Hz, 15 Amps for Models 90750-00 (230 VAC, 50 Hz, 10 Amps for Models 90750-02).

Feed water Requirements

The WaterPro RO Stations are designed for use with feed water that has a minimum pressure of 30 psi, and minimum flow rate of 1.6 gal/min. and a negative Langelier Saturation Index. (A positive LSI, requires water softener pretreatment, see Inlet Water Specifications on page 8 for additional information).

<p>IMPORTANT NOTE: System performance, membrane, and cartridge life span are directly related to the feed water. It is important to establish feed water pressure, and flow rate, before installing and operating the unit. If your feed water, or feed water quality has not been tested, contact Labconco at 1-800-821-5525 or 1-816-333-8811.</p>

INSTALLATION

WARNING: Do not install the WaterPro RO Station directly over or near equipment that uses electrical service. Routine use and maintenance of the unit may involve water spillage. A potential for electrical shock hazard exists if improperly located.

Location

Locate the RO Station close to a water source and drain. The unit can be wall mounted or mounted on the optional stands. There are two drain lines. One is from the tank overflow drain and the other is from the RO. Direct both drain lines to a floor drain located below the exit points of the WaterPro RO Station, and secure in place. Drain must be located lower and must be able to handle a minimum of 2-gal/min water flow.

Unfold the installation template included and follow the instructions to prepare surface for mounting. Mounting surface composition, condition and construction must be considered when mounting this unit. The surface must be able to support at least 500 pounds. Inadequate support may result in damage to the mounting surface and/or equipment. We have provided ¼ -14 x 1.25" Lg. tapping screws (1895320) for securing the unit to the wall. If the optional support stand has been purchased, discard template and follow instructions with stand.

Wall mounted units require a minimum of 6" clearance on the bottom for cartridge, and membrane installation/removal.

Feed Water Connection

The supplied feed water is 3/8" OD (0.95 cm) rigid plastic tubing. If more tubing is required, refer to Replacement Parts section, page 27 in this manual. The tubing is inserted into the inlet port identified as #14 on page 27. At a convenient spot in the supply line, a valve should be installed so the WaterPro RO may be isolated from the feed water supply when required. Line pressure should not exceed 100 psi (7 Bar). Feed water line must be able to supply 1.6 gal/min at a minimum pressure of 30 psi or pump cycling will occur.

To connect the feed water supply to the inlet port, cut the tube with a sharp knife, check for burrs, and insert as explained in the Tubing Installation section below.

Tubing Installation

The tubing connectors used in the WaterPro RO have been selected for their dependability and ease of installation. A detailed drawing of a typical connection is shown in Figure 4.

For flexible tubing, be sure to insert a tube support into the end of the tubing. Rigid tubing does not require the use of a tube support.

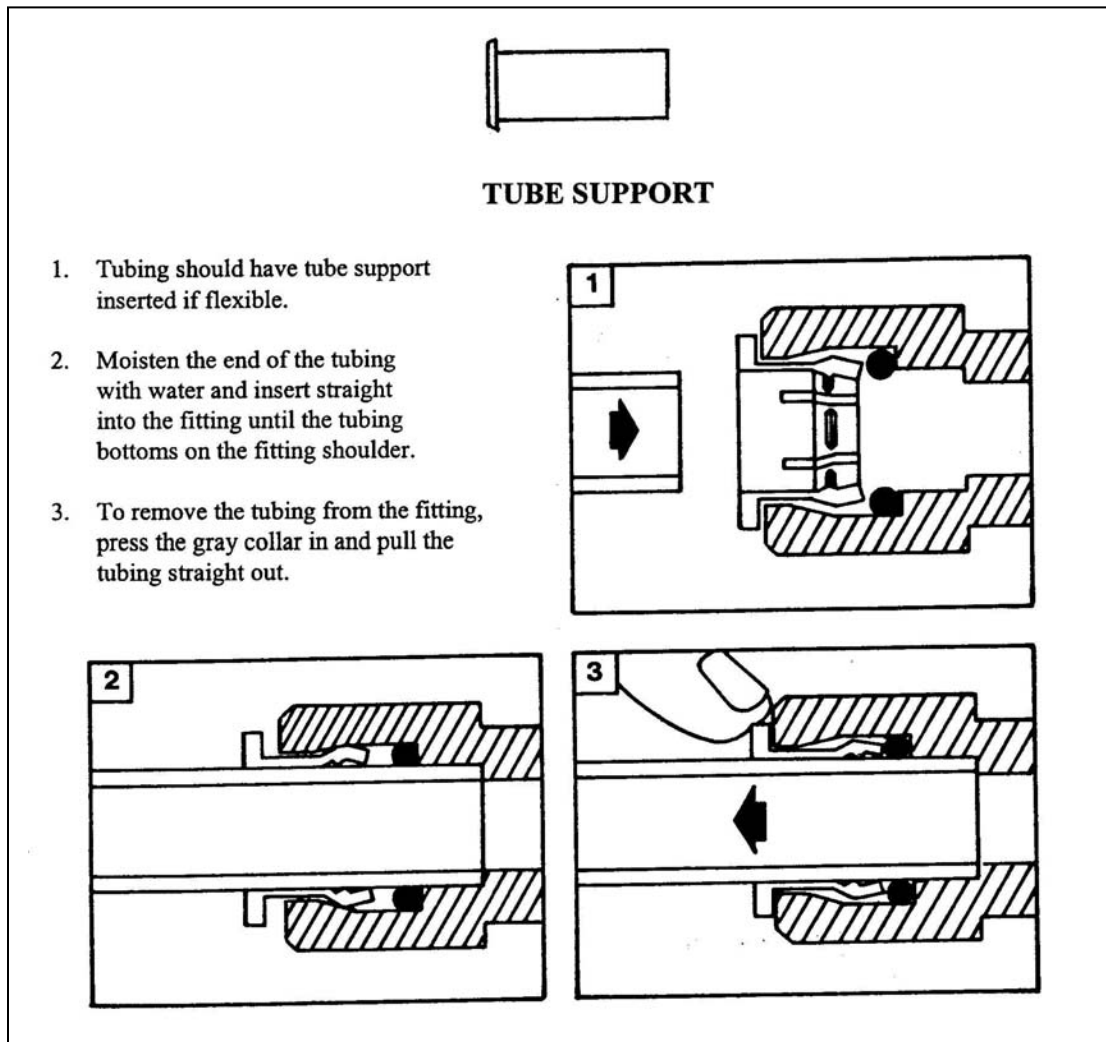

Figure 4

Utility Connections

The electrical outlet should be rated at 115 VAC, 60 Hz, 15 Amps for models 90750-00 (230 VAC, 50 Hz, 10 Amps for models 90750-02) and be dedicated to the RO system only.

Refer to RO Specifications section for feed water requirements.

INSTALLATION

Optional Dispense Gun Installation

1. Close feed water supply line valve and relieve pressure in system by pressing dispense button. Disconnect from electrical power after relieving pressure.
2. Remove the two screws located on the front of the cabinet cover with a Phillips screwdriver. Loosen the two screws located on top of the cover and remove cover.
3. Remove the metal bracket with the grommet from the plastic bag.
4. Remove the storage tank cover by lifting up and pulling out. Remove the storage tank by tilting tank forward and disconnecting the float switch, electrical connection and the tank fill tubing. See Gun Installation Instruction Sheet.
5. Install the bracket on the right side of the storage tank housing using the hardware provided. See Gun Installation Instruction Sheet.
6. Remove the dispense gun with the tubing from the shipping carton.
7. Inside the cabinet of the RO unit, locate the fitting marked “GUN”, which is located next to the pressure switch. Remove the plug in this fitting by pressing down on the gray collar to release the plug.
8. Push the black short tubing of the dispense gun into the end of the fitting marked gun.
9. Set the gun trigger to the constant ON position and direct to drain.
10. Connect unit to electrical supply. Turn on the feed water supply valve.
11. Allow water to fill the clear tubing attached to the gun and then close the trigger to stop flow. Check for leaks.
12. Place gun in previously installed bracket so that the nozzle of the gun inserts into the black grommet on the bracket and the tubing clamps into the hose slot provided.
13. The unit is ready to be used.

RO Membrane Installation

1. Install prefilter, P/N 90927, in first bowl on the right side of the unit with the O-Rings pointing up. Use Spanner Wrench for bowl removal. Wear sterile laboratory gloves to prevent contamination of filters.
2. Install one carbon/filter P/N 90622 in second bowl from the right with the O-Rings pointing up.
3. Remove the braided tubing from the connector in the bottom of the third bowl by pressing the gray collar back towards the connector and pulling the tubing straight out. (See Tubing Installation, page 12).
4. With the Spanner Wrench remove the third bowl from the unit.
5. Center the lower spacer disk over the support post in the bottom of the bowl. **NOTE:** Orient the disk in the bowl so that the slots are upward. (See Figure 5).
6. Install the lower adaptor into the bottom of the RO membrane by pushing it until it seats firmly.
7. Install the upper adaptor in the top of the RO membrane by twisting while pushing until it seats firmly.
8. Place the Reverse Osmosis membrane in the bowl, such that the upper adaptor is in the top of the bowl.
9. Install the bowl. Do not over tighten.
10. Connect the tubing into the elbow. A firm tug on the tubing should not pull it out.
11. Connect a drain line to the dispensing valve.
12. Set timed dispense for 1.5 hours and start unit. After time runs out unit will automatically shut off. (Be sure prefilter and carbon/prefilter are in place).
13. Unit is ready for operation.

INSTALLATION

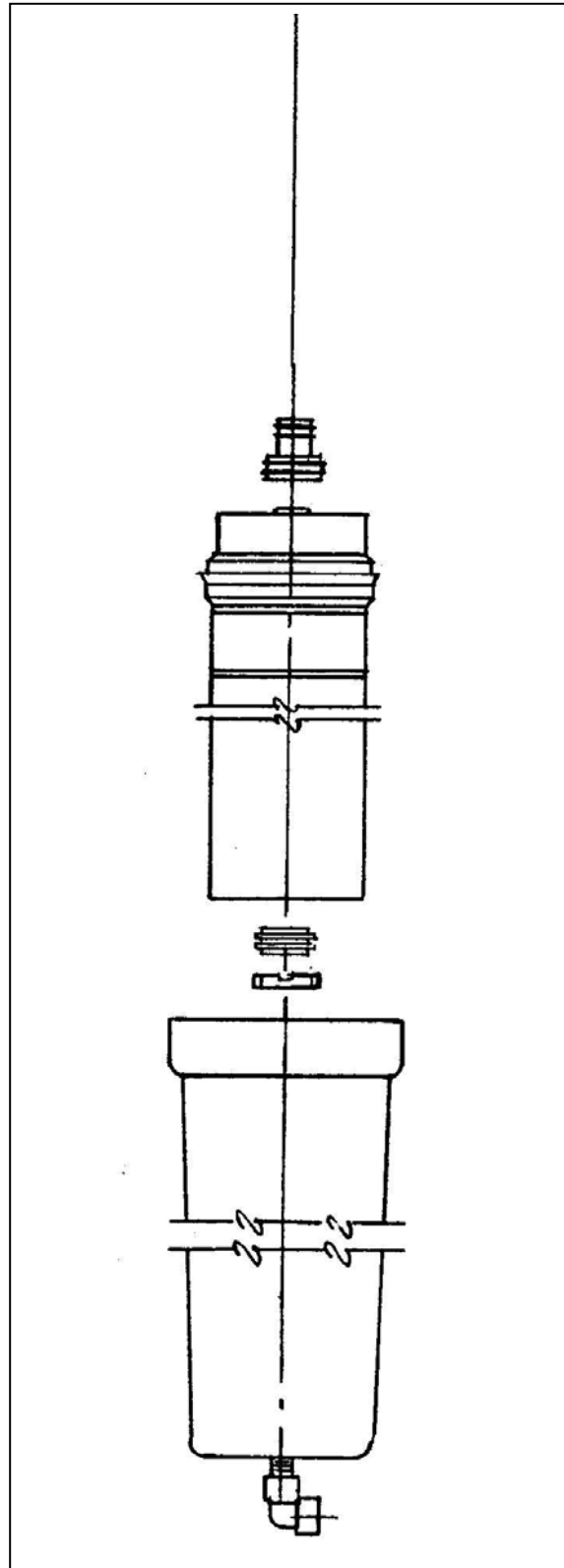

Figure 5

WaterPro PS and Glassware Washer Feed

The WaterPro RO can be used to feed purified water to the WaterPro PS Polishing Station and Labconco's Glassware Washers. To make the connection(s), first empty the storage tank of stored water. Remove a gray plug located on the bottom of the storage tank and insert tubing from either the Glassware Washer or the WaterPro PS. Connection of both the PS and Glassware Washer can be made with the use of a tee.

NOTE: The Glassware Washer will require a full tank at the beginning of the purified rinse cycle and also requires RO water production during the first purified rinse. Use of RO water from the tank or dispense valve during the washer rinse cycle may result in a short fill for the washer. While the storage tank is filling with water the flow rate to the dispense valve will be diminished.

SAFETY PRECAUTIONS

- Pretreat feed water appropriately as indicated by Labconco Water Profile test, to extend life of the RO membrane.
- Change prefilters frequently as stated in this manual to prevent free chlorine from destroying the RO membrane.
- Ensure that the unit is connected to electrical service according to local and national electrical codes. Failure to do so may create a fire or electrical hazard.
- Do not remove or service any electrical components without first disconnecting the RO system from the outlet.
- Preserve RO membrane whenever unit is unplugged for more than a week without usage per instructions under “Preserving RO Membrane” page 24.
- Mounting surface composition, condition and construction must be considered when mounting this unit. The surface must be able to support at least 500 pounds. Inadequate support may result in damage to the mounting surface and/or equipment.
- System performance and cartridge life span are directly related to the feed water quality. It is important to establish feed water quality before operating the unit.

WARNING: Do not install the WaterPro RO over or near equipment that uses electrical service. Routine use and maintenance of the unit may involve water spillage and the potential for electrical shock if improperly located.

WARNING: The WaterPro RO automatically starts and stops at intervals during nonuse. To prevent the possibility of water spillage or electrical shock, always unplug the unit prior to servicing the unit.

**WARNING: When sanitizing the system or preserving the membrane:
Avoid splashing the solution on skin or clothing.
Ensure that all piping connections are tight to avoid leakage.
Always depressurize the system COMPLETELY before disassembly.
Ensure adequate ventilation.**

Carefully follow the manufacturer’s safety instructions when handling sanitizers, and always dispose of sanitizing solutions in accordance with local and national laws.

NOTE: Mounting surface composition, condition and construction must be considered when wall mounting this unit. The surface must be able to support at least 500 lbs. Inadequate support may result in damage to the mounting surface and/or equipment.

Thoroughly understand procedures and equipment before beginning work. Prefilter, carbon/prefilter and RO membrane should already be installed. See page 14 of this manual.

Electronic Control

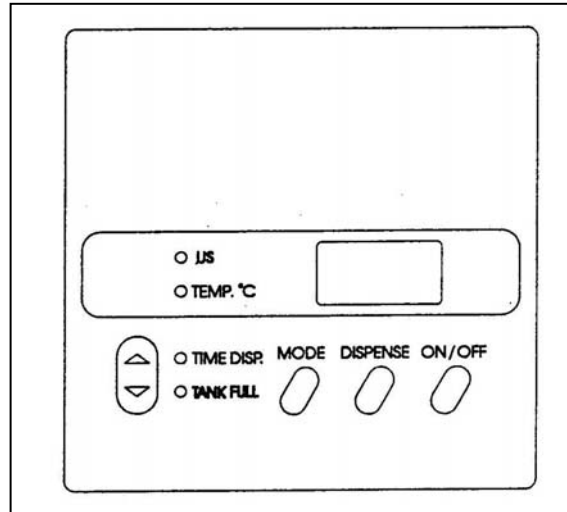

Figure 6

1. **ON/OFF Switch.** This switch turns on the unit and lights the display. When the switch is in the OFF or ON position the pump will automatically start to flush the RO membrane and tank for three minutes every 12 hours of inactivity. Before automatic flush occurs the units must be connected to an electrical supply and inactive for the 12-hour period.
2. **Mode.** This key selects the mode of operation and displays the water purity measured in conductivity.
 - a. **Microsiemens (μS).** This is the normal operating mode and displays the water purity measured in conductivity.
 - b. **Temp.** Displays temperature of the water in degrees Centigrade.
 - c. **Time Dispense.** Displays amount of time in minutes the system will dispense water from the dispense valve. Time can be increased or decreased using arrow keys.
3. **Tank Full.** Light illuminates when the storage is full.
4. **Dispense.** Pressing this key delivers water from the dispense valve. The key must be held down to continue dispensing. The delivery will be time controlled if that mode has been selected, and value entered into the display.

NORMAL OPERATIONS

Initial Start Up

- Pretreat feed water as recommended by Labconco based upon the Water Profile test.
- Plug unit in electrical outlet. Turn unit ON.
- Turn the feed water valve ON.
- Connect tubing to dispensing valve and direct to drain. (For gun installation, extend gun to drain and click into the ON position).
- Set timed dispense to 99 minutes.
- Operate unit for 99 minutes to purge preservative to drain.
- Dispensing valve will close automatically, storage tank will fill and unit will automatically shut off.
- Unit is now ready to dispense RO water any time from the dispensing valve, optional dispensing gun or from the storage tank.

Automatic Flush Valve

The unit is equipped with a flush valve. The flush valve automatically opens every 12 hours of inactivity to flush the membrane and storage tank. In order for the flush valve to work, keep the unit plugged into an electrical outlet at all times.

Work Techniques

- Use clean glassware to collect RO water.
- Always leave unit plugged into electrical outlet. Disconnect unit to service.
- Preserve membrane if unit is left unplugged for more than a week.
- Check to ensure security of drain lines.
- Keep a log of RO performance.

Shut Down

When changing the filters or cleaning the unit, do the following:

- Turn ball valve to ON position to drain water and relieve pressure.
- Unplug unit from electrical outlet.
- Turn feed valve OFF.

Start Up

- Plug unit into electrical outlet.
- Turn feed water valve ON.
- Turn unit ON.
- Open dispensing valve to vessel to be filled and dispense.

MAINTENANCE

Under normal operation, your RO unit will require little routine maintenance. The following schedule is recommended.

Weekly

- Change prefilter and carbon/prefilter if more than 500 gallons of feed water have been processed.
- Clean unit of any dust.
- Preserve unit if unplugged for more than one week.

Monthly

- Change prefilter and carbon/prefilter once every two months.
- All weekly activities.

Quarterly

- Change air vent filter.

Annually

- Clean RO membrane.
- Disinfect unit.
- All monthly activities.

Biennial (once every two years)

- Replace RO membrane if the normalized (flow rate at 25°C see chart on page 30) flow rate has decreased by 20% or more.
- All annual activities.

Sanitization

Sanitization is necessary when the RO element or storage tank become biologically fouled. Biological fouling of the RO is an obstruction due to living or dead bacteria on the membrane or tank surface. This may occur if the RO is left stagnant without flushing for more than a week.

If biological fouling of the membrane occurs, the unit should be sanitized with 0.1% (wt/wt) formaldehyde as follows:

1. Collect approximately 4 liters of RO purified water in a container and set aside.

CAUTION: Use only chlorine-free water. Use of chlorinated tap water will degrade and destroy the RO membrane.

2. Shut off the feed water valve. Relieve the water pressure in the unit by opening the dispense valve (dispense gun, if installed) and directing the water to drain.
3. Disconnect the unit by unplugging it from the outlet.
4. Remove both 20" prefilter and 20" carbon/prefilter cartridges. Do not remove RO membrane.
5. Carefully wash inside the prefilter bowl, carbon/prefilter bowl and storage tank with liquid detergent using a clean sponge or cloth. Rinse out the bowls several times to remove any residue.
6. Prepare 0.1% formaldehyde in the RO purified water collected in Step 1.

CAUTION: Prepare and handle solutions in well-ventilated areas. Wear protective clothing, gloves and eye protection. Dispose of excess or spillage properly.

7. Install a new 20" prefilter cartridge, P/N 90210-00 in the empty, clean 20" bowl.
8. Fill the carbon/prefilter bowl with the 0.1% formaldehyde.
9. Reinstall the bowls in their correct position.
10. Plug the unit into the electrical outlet. Reopen the feed water valve.
11. Start the RO unit with the dispense valve open. Allow the unit to run for five minutes.
12. Turn off feed water supply and press the manual dispense button to relieve the pressure.
13. Remove the tank and sanitize with formaldehyde solution.
14. Allow the unit to stand for 1 hour.
15. If the system will not be in use for an extended time, leave the formaldehyde solution in the system.
16. If the system is to be returned to service, flush the residual solution from the vessel for 1 hour by attaching a hose to the dispensing valve and setting time dispense to 60 minutes.

DECONTAMINATION/CLEANING

Both inorganic and organic fouling are indicated when either or both of the following occur:

- The normalized (temperature corrected) product flow rate drops by 20%.
- The conductivity of the permeate rises noticeably.

Inorganic Fouling

Inorganic fouling of the membrane is caused by mineral scale such as:

- Calcium carbonate
- Calcium sulfate
- Barium sulfate
- Strontium sulfate
- Iron or manganese

Inorganic fouling can be cleaned with the following recommended solutions:

0.5% HCl with a final pH of 2

Procedure

1. Collect approximately 4 liters of reverse osmosis water in a container and set aside for use in preparing the cleaning solution.

CAUTION: Use chlorine-free water to prepare the cleaning solutions. The use of chlorinated tap water will destroy the reverse osmosis membrane.

2. Shut off feed water valve.
3. Relieve the water pressure in the unit by opening the dispense valve and directing the water to a drain.
4. Disconnect the RO unit from the electrical power source by unplugging the unit.
5. Remove the carbon/prefilter cartridge and discard the water.
6. Fill the carbon/prefilter bowl approximately $\frac{3}{4}$ full with the cleaning solution.
7. Reinstall the bowl.
8. Open the feed water valve.
9. Plug the unit into an electrical outlet, activate the unit and allow it to operate for 5 minutes.
10. Disconnect the unit from the electrical outlet and allow the membrane to soak for at least 2 hours.
11. Relieve the pressure in the system by connecting unit to an electrical outlet and pressing the dispense button.

CAUTION: Do not attempt to remove the acid-filled bowls when the system is pressurized.

12. Carefully remove the prefilter bowl and dispose of the water appropriately.

CAUTION: The water in the bowl contains cleaning solution. Handle and dispose of properly.

13. Install a new prefilter (first bowl from right) and carbon/prefilter (second bowl) cartridges.
14. Connect a hose to the dispensing valve and route to drain. Activate the unit by connecting the unit to an electrical outlet. Set time dispense for 60 minutes and direct water to drain.
15. At the end of the hour, set off water feed valve and release the pressure by pressing the dispense button.
16. Start the unit. The RO module is now ready for normal operation.

Organic Fouling

Organic fouling of the membrane can be caused by silt, bacterial slime, or any other organic materials.

The following recommended cleaners may be used:

- Sodium hydroxide 0.5%
- Sodium dodecyl sulfate 0.1% (Adjust pH to 11.5 with HCl, if necessary)
- Trisodium phosphate, 1%
- Sodium tri-polyphosphate, 1%
- Tetra sodium EDTA, 1% (Adjust pH to 11.5 with HCl, if necessary)

For cleaning procedure, follow steps 1 through 17 under Inorganic Fouling.

Preserving RO Membrane

If the system will not be in use (without electricity) for over a week, preserve with 0.1% formaldehyde.

1. Collect approximately 4 liters of RO purified water in a container. Set aside.
2. Shut off the fed water valve and relieve the water pressure in the unit by pressing the dispense button.
3. Disconnect from the electrical supply. Remove both 20" prefilter and 20" carbon/prefilter cartridges. Do not remove RO membrane.
4. Carefully wash inside the prefilter bowl, carbon/prefilter bowl and storage tank with liquid detergent using a clean sponge or cloth. Rinse out the bowls and tank several times to remove any residue.
5. Prepare 0.1% formaldehyde in the RO purified water collected in Step 1.
6. Install a new 20" prefilter cartridge, P/N 90210-00 in the first bowl from the right.
7. Fill the carbon/prefilter bowl with the 0.1% formaldehyde.
8. Reinstall the bowls in their correct position.
9. Plug the unit into the electrical outlet. Reopen the feed water valve.
10. Activate the unit and allow it to operate for 5 – 10 seconds.
11. Close off feed water and disconnect from electrical source.

SERVICE

Front Cover Removal

1. Remove the two black screws on the front panel.
2. Loosen the two screws on the top and remove the cover.

Prefilter and Carbon/Prefilter Replacement

NOTE: Prefilter – change at least once a month, carbon/prefilter change at least once every two months.

1. Shut off feed water supply and release pressure in the system by pressing the dispense valve button.
2. With the Spanner wrench provided, remove the first bowl on the right.
3. Remove the old prefilter.
4. Discard water in bowl.
5. Clean the bowl with mild soap and water, rinse and towel dry.
6. Insert new prefilter and place bowl on unit.
7. Hand tighten bowl in place. Do not use wrench to tighten as this may damage the bowl.

Air Vent Filter Replacement

1. Remove old filter and discard. Press new filter in tubing.

EXPENDABLES

<u>KIT #</u>	<u>DESCRIPTION</u>
90787-00	Reverse Osmosis membrane and adaptor package is required for operation
90622-00	Replacement carbon/prefilter contains 2 each.
90672-01	Prefilter/Carbon Filter Kit required for operation. Includes prefilters (3), carbon filters (3), for initial start-up and two filter changes.
19305-00	Air Vent Filter
<u>PART #</u>	
90927-00	20" Prefilter, combination carbon
90594-00	20" Carbon/Prefilter 1 of 90622-00
90786-00	RO Membrane

REPLACEMENT PARTS

<u>ITEM #</u>	<u>QUANTITY</u>	<u>PART #</u>	<u>DESCRIPTION</u>
1	1	1363300	Check Valve
2	1	9105300	Conductivity Sensor
3	1	1329100	Low Pressure Switch
4	1	1303200	High Pressure Switch
5	1	9047503	Pump Assy 115V
5a	1	9047502	Pump Assy 230V
6	1	9106500	Valve - Dump/Dispense 115V/Inlet
6a	1	9108900	Valve – Dump/Dispense 230V/Inlet
7	1	1210101	Motor Pump, 115V
7a	1	1210102	Motor Pump, 230V
8	1	1953500	Pressure Gauge
9	1	9112300	PC Board Assembly
10	1	9111200	Level Switch
11	1	1365100	Valve, Pressure Relief
12	1	1930500	Air Vent Filter
13	1	9110700	Tank, Water Storage
14	5 ft.	1552500	Drain Tubing – not shown
15	5.3 ft.	9013201	Tank Overflow Drain Tubing – not shown
16	5.0 ft.	9013415	Inlet Connection Tubing – not shown

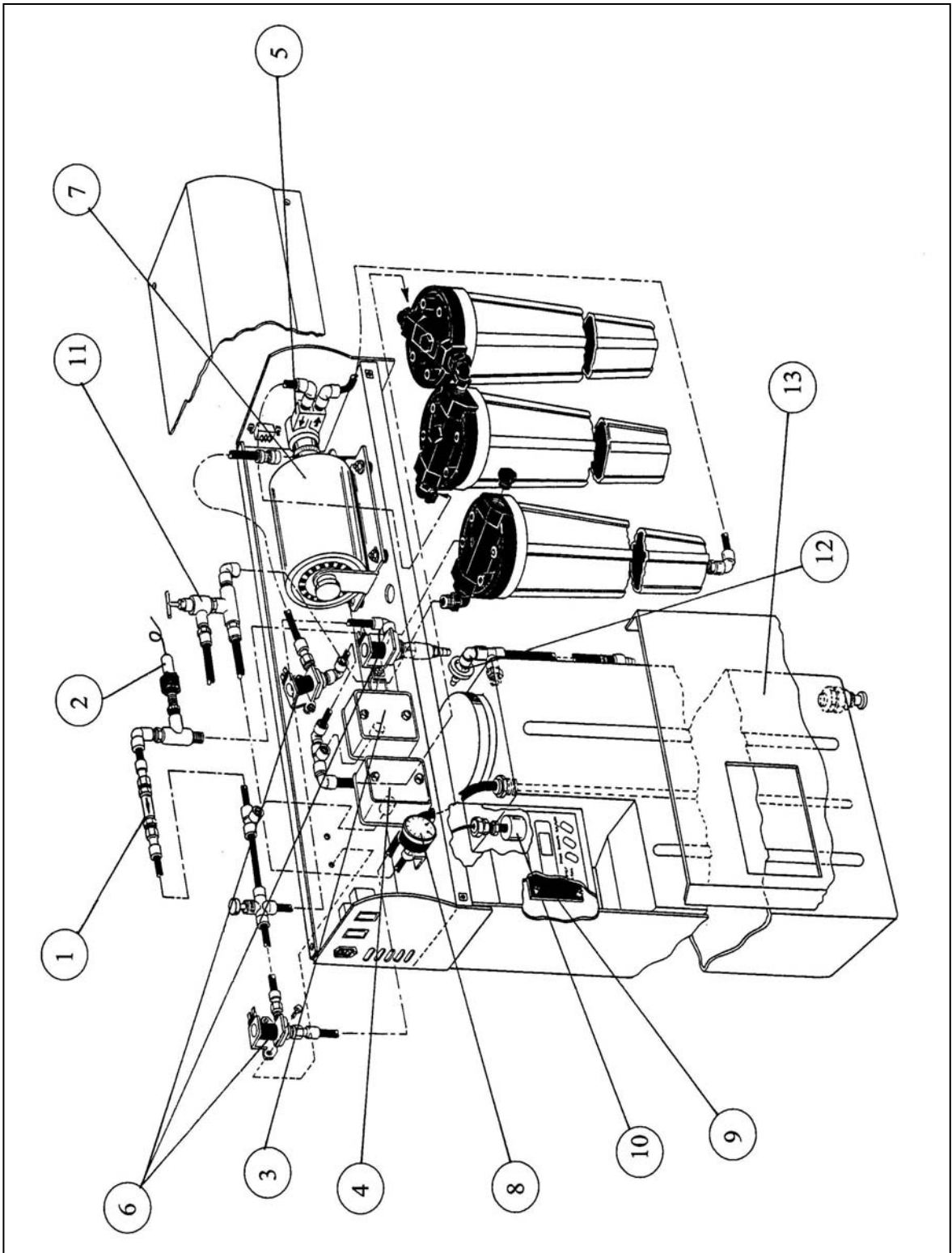

Figure 7

DIMENSIONAL DRAWING

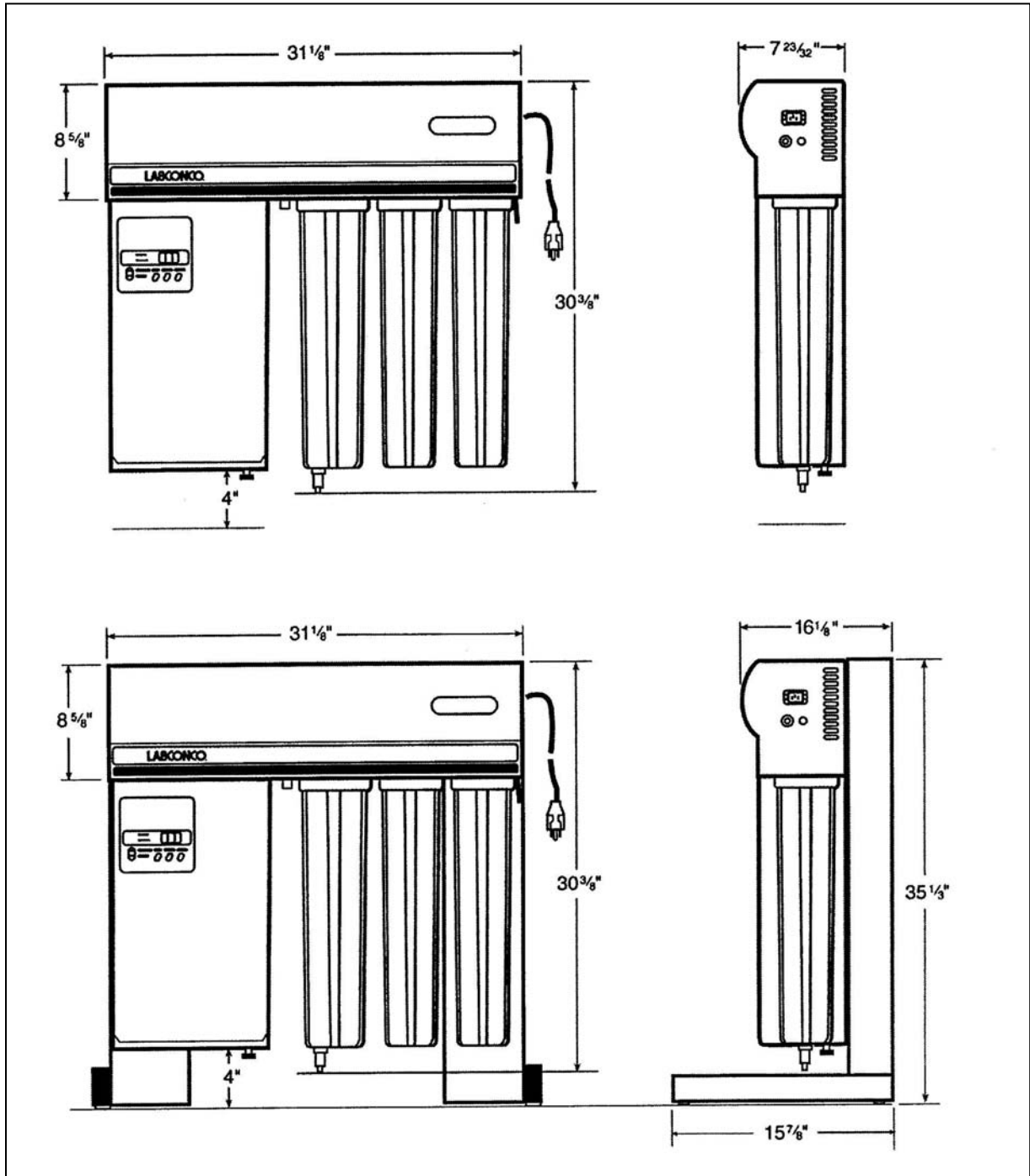

Figure 8

RO PRODUCTION RATES TABLE

**R/O Production Rates Versus Feed Water Temperature
R/O Production Rates in Liters/Minute**

**Temperature
C**

30	0.58	0.69	0.80	0.92	1.04	1.15	1.27	1.38	1.50	1.61	1.73	1.84	1.96	2.07	2.19	2.30
29	0.56	0.67	0.78	0.90	1.01	1.12	1.23	1.34	1.46	1.57	1.68	1.79	1.90	2.02	2.13	2.24
28	0.55	0.65	0.76	0.87	0.98	1.09	1.20	1.31	1.42	1.53	1.64	1.74	1.85	1.96	2.07	2.18
27	0.53	0.64	0.74	0.85	0.95	1.06	1.17	1.27	1.38	1.48	1.59	1.70	1.80	1.91	2.01	2.12
26	0.52	0.62	0.72	0.82	0.93	1.03	1.13	1.24	1.34	1.44	1.55	1.65	1.75	1.85	1.96	2.06
25	0.50	0.60	0.70	0.80	0.90	1.00	1.10	1.20	1.30	1.40	1.50	1.60	1.70	1.80	1.90	2.00
24	0.49	0.58	0.68	0.78	0.87	0.97	1.07	1.16	1.26	1.36	1.46	1.55	1.65	1.75	1.84	1.94
23	0.47	0.56	0.66	0.75	0.85	0.94	1.03	1.13	1.22	1.32	1.41	1.50	1.60	1.69	1.79	1.88
22	0.46	0.55	0.64	0.73	0.82	0.91	1.00	1.09	1.18	1.27	1.37	1.46	1.55	1.64	1.73	1.82
21	0.44	0.53	0.62	0.70	0.79	0.88	0.97	1.06	1.14	1.23	1.32	1.41	1.50	1.58	1.67	1.76
20	0.43	0.51	0.60	0.68	0.77	0.85	0.94	1.02	1.11	1.19	1.28	1.36	1.45	1.53	1.62	1.70
19	0.41	0.49	0.57	0.66	0.74	0.82	0.90	0.98	1.07	1.15	1.23	1.31	1.39	1.48	1.56	1.64
18	0.40	0.47	0.55	0.63	0.71	0.79	0.87	0.95	1.03	1.11	1.19	1.26	1.34	1.42	1.50	1.58
17	0.38	0.46	0.53	0.61	0.68	0.76	0.84	0.91	0.99	1.06	1.14	1.22	1.29	1.37	1.44	1.52
16	0.37	0.44	0.51	0.58	0.66	0.73	0.80	0.88	0.95	1.02	1.10	1.17	1.24	1.31	1.39	1.46
15	0.35	0.42	0.49	0.56	0.63	0.70	0.77	0.84	0.91	0.98	1.05	1.12	1.19	1.26	1.33	1.40
14	0.34	0.40	0.47	0.54	0.60	0.67	0.74	0.80	0.87	0.94	1.01	1.07	1.14	1.21	1.27	1.34
13	0.32	0.38	0.45	0.51	0.58	0.64	0.70	0.77	0.83	0.90	0.96	1.02	1.09	1.15	1.22	1.28
12	0.31	0.37	0.43	0.49	0.55	0.61	0.67	0.73	0.79	0.85	0.92	0.98	1.04	1.10	1.16	1.22
10	0.29	0.35	0.41	0.46	0.52	0.58	0.64	0.70	0.75	0.81	0.87	0.93	0.99	1.04	1.10	1.16
9	0.28	0.33	0.39	0.44	0.50	0.55	0.61	0.66	0.72	0.77	0.83	0.88	0.94	0.99	1.05	1.10
8	0.26	0.31	0.36	0.42	0.47	0.52	0.57	0.62	0.68	0.73	0.78	0.83	0.88	0.94	0.99	1.04
7	0.25	0.29	0.34	0.39	0.44	0.49	0.54	0.59	0.64	0.69	0.74	0.78	0.83	0.88	0.93	0.98
6	0.23	0.28	0.32	0.37	0.41	0.46	0.51	0.55	0.60	0.64	0.69	0.74	0.78	0.83	0.87	0.92
5	0.22	0.26	0.30	0.34	0.39	0.43	0.47	0.52	0.56	0.60	0.65	0.69	0.73	0.77	0.82	0.86

To read this chart: For example, if your regular Flow rate is 1.00 liter at 25°C, read the 25°C in the left column, move across the page to the 1.00. If the temperature of the water is now 19°C, locate 19°C on the left side and move across into the same column as the 1.00. The flow rate will now be 0.82 LPM (820 ml/min).

WIRING DIAGRAM

115V Wall Mount and Bench top
Models 90750 and 90751

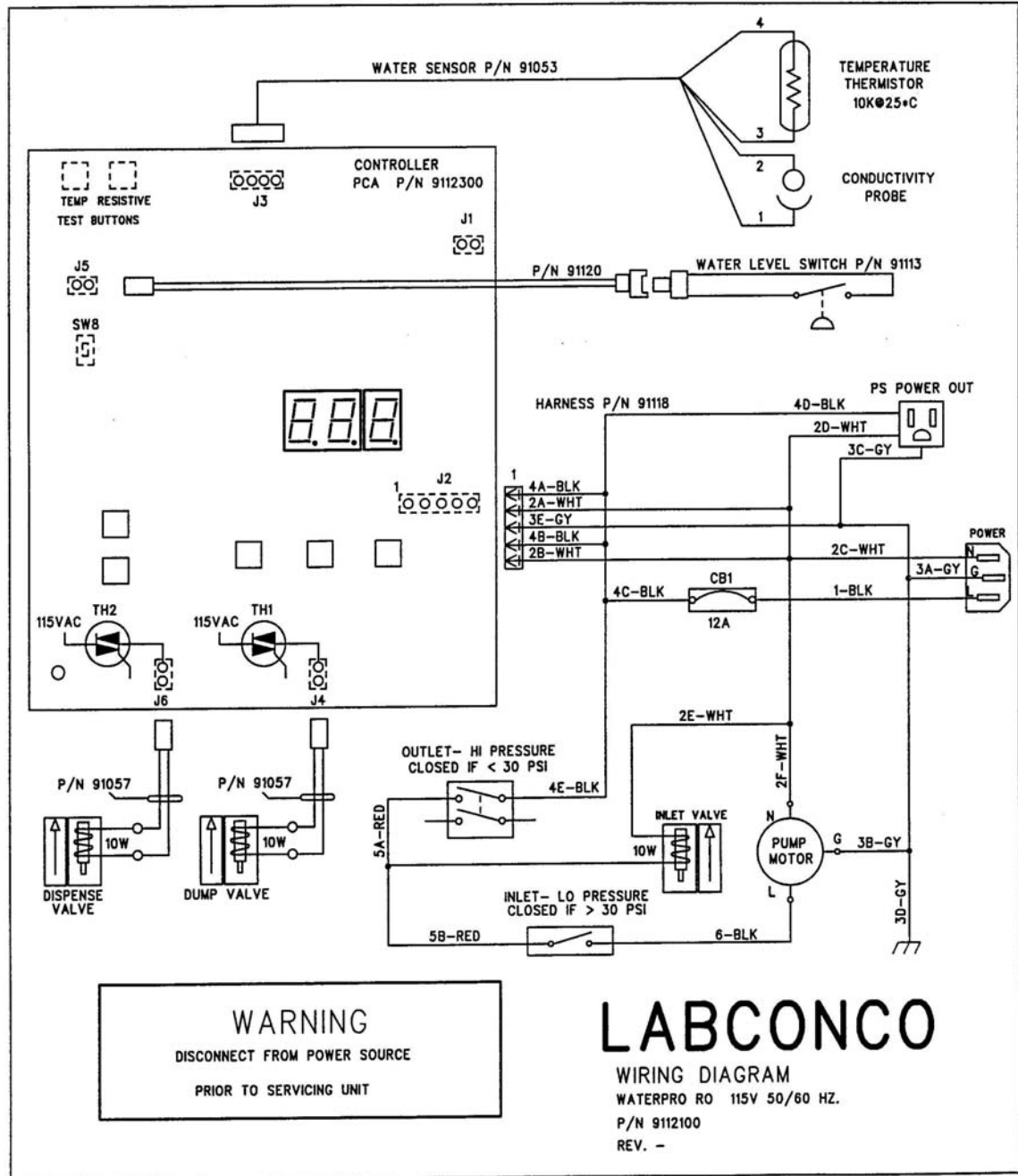

WIRING DIAGRAM

230 V Wall Mount and Bench Top
Models 90750-02 and 90751-02

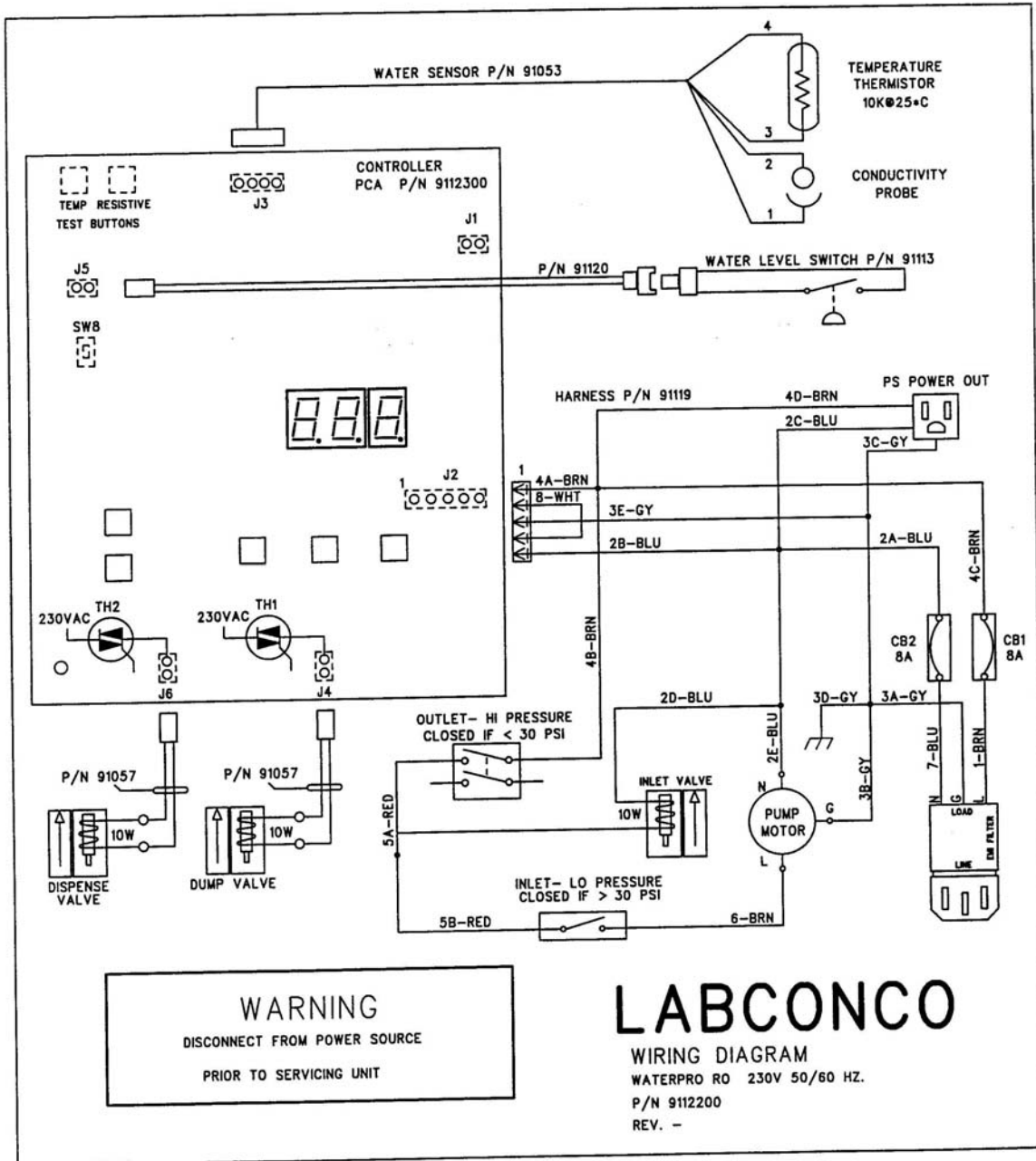

TROUBLESHOOTING

<u>PROBLEM</u>	<u>CAUSES</u>	<u>CORRECTIVE ACTION</u>
Unit inoperative no display	Unit not plugged into outlet	Plug WaterPro RO into appropriate electrical service
	Circuit breaker tripped/fuse blown	Reset circuit breaker/replace fuse
	Power Switch is in the OFF position	Press power button to switch system on
	Defective circuit board	Replace circuit board
Pump does not operate and no water is dispensed	Customer supplied Feed valve is closed	Open the valve
	Feed water line is restricted, or no supply	Inspect and adjust feed water line as required
	Pump is defective	Replace pump
Reduced flow at dispense valve/gun and storage tank slow to fill	Restricted tube in the feed line or polishing system	Inspect polishing loop tubing for any restrictions
	Insufficient feed water pressure and flow rate	Pressure must be a minimum of 30 psi at a flow rate of at least 6 liters per minute
	Partial open feed valve	Open feed valve fully
	Plugged prefilter and/or carbon filter	Replace filters
	Water temperature less than 25°C	Install water temperature mixing valve
	Kinked or restricted tubing in system	Trace restriction and remove or straighten tube

TROUBLESHOOTING

<u>PROBLEM</u>	<u>CAUSES</u>	<u>CORRECTIVE ACTION</u>
Water quality display acting erratically	Decrease in RO back pressure	Increase back pressure relief valve to 150 psi
	New cartridges installed in system	Purge all of the air out of the polishing system
	Air trapped in conductivity cell	Purge all of the air out of the RO system
	Polishing loop conductivity cell not connected to wiring harness	Reconnect cell to wiring harness
Display reads 000	Conductivity cell is defective	Replace cell
	Conductivity sensor disconnected from harness	Connect sensor to harness from circuit board
Increase in μS (microsiemen) reading	Air in conductivity sensor	Purge unit until air is expelled by opening the dispensing valve
	High inlet TDS	This is normal. With increased inlet TDS, RO μS increases
Excessively high μS	RO membrane scaling or other deposits	Clean membrane per instructions in RO cleaning section
	RO membrane fouled Biofilm formed	Clean RO membrane per instructions in RO cleaning section
	RO poisoned Chlorine damage	Replace RO membrane and prefilters per installation instructions

WARRANTY

We are committed to providing our customers with quality equipment and service after the sale. Part of this objective involves keeping you informed of changes and new product additions. We, therefore, request that you take a moment to fill out the product registration card so we may know your location as well as some of the reasons that prompted you to purchase our product.

Labconco provides a warranty on all parts and factory workmanship. The warranty includes areas of defective material and workmanship, provided such defect results from normal and proper use of the equipment.

The warranty for all Labconco products will expire one year from date of installation or two years from date of shipment from Labconco, whichever is sooner, except the following:

- Purifier® Delta™ Series Biological Safety Cabinets carry a three-year warranty from date of installation or four years from date of shipment from Labconco, whichever is sooner.
- Carts carry a lifetime warranty.
- Glassware is not warranted from breakage when dropped or mishandled.

This limited warranty covers parts and labor, but not transportation and insurance charges. In the event of a warranty claim, contact Labconco Corporation or the dealer who sold you the product. If the cause is determined to be a manufacturing fault, the dealer or Labconco Corporation will repair or replace all defective parts to restore the unit to operation. Under no circumstances shall Labconco Corporation be liable for indirect, consequential, or special damages of any kind. This statement may be altered by a specific published amendment. No individual has authorization to alter the provisions of this warranty policy or its amendments. Lamps and filters are not covered by this warranty. Damage due to corrosion or accidental breakage is also not covered.

WARNING: The disposal and/or emission of substances used in connection with this equipment may be governed by various federal, state or local regulations. All users of this equipment are urged to become familiar with any regulations that apply in the user's area concerning the dumping of waste materials in or upon water, land or air and to comply with such regulations.

SHIPPING CLAIMS

If a shipment is received in visibly damaged condition, be certain to make a notation on the delivering carrier's receipt and have their agent confirm the damage on your receipt. Otherwise, the damage claim may be refused.

If concealed damage or pilferage is discovered, notify the carrier immediately and retain the entire shipment intact for inspection. Interstate Commerce Commission rules require that the claim be filed with the carrier within 15 days after delivery.

NOTE: Do not return goods. Goods returned without prior authorization will not be accepted. Labconco Corporation and its dealers are not responsible for shipping damage. Claims must be filed directly with the freight carrier by the recipient. If authorization has been received to return this product, by accepting this approval, the user assumes all responsibility and liability for biological and chemical decontamination and cleansing. Labconco reserves the right to refuse delivery of any products, which do not appear to have been properly cleaned and/or decontaminated prior to return.

ACCESSORIES

<u>ACCESSORY PART #</u>	<u>DESCRIPTION</u>
91131-00	Gun Kit Allows in field installation of an optional gun to dispense RO water
90774-00	Support Stand for converting wall mounted WaterPro RO Station to bench mounted
91132-00	WaterPro RO/PS Mobile Stand allows the mounting of a RO and a PS on the same mobile stand
13060-00	WaterPro RO/PS 125-230 Volt, 10 amp, electrical connecting cord for connecting PS to RO when mounted within 15 inches of each other

CONTACTING LABCONCO

If you have any questions that are not addressed in this manual, or if you need technical assistance, please contact Labconco's Sales Information Department at 1-800-821-5525, and Service Information at 1-800-522-7658 or 1-816-333-8811, between the hours of 7:00 a.m. and 6:00 p.m. Central Standard Time.

Labconco's mailing address is:

Labconco Corporation
8811 Prospect Avenue
Kansas City, Missouri 64132-2696

Fax # 816-363-0130

Visit Labconco through the Internet at:

<http://www.labconco.com>

or

email: labconco@labconco.com

DECLARATION OF CONFORMITY

Application Council Directive(s): 73/23/EEC, 89/336/EEC

Standard(s) to which conformity is declared: EN61010, EN55014, EN50082-1

Manufacturer's Name: Labconco Corporation

Manufacturer's Address: 8811 Prospect Avenue
Kansas City, MO 64132 USA

Importer's Name: See Shipping/Customs Documents*

Importer's Address: See Shipping/Customs Documents for your equipment

Type of Equipment: Laboratory Equipment – Water Purification

Model No.: WaterPro RO – 90750-02

Serial No.: Various – See Individual Declaration

Year of Manufacture: 1995 and Subsequent

I, the undersigned, hereby declare that the equipment specified above conforms to the above Directive(s) and Standard(s).

See individual Declaration of Conformity which will be signed by the importer for your country.

Place: _____
(Signature)

Date: _____
(Full Name)

(Position)

*An individual version of this declaration is included with your shipping/customs documentation.