



LABCONCO CORPORATION

8811 Prospect Avenue
Kansas City, MO 64132
(800) 821-5525, (816) 333-8811
(816) 363-0130 fax
labconco@labconco.com

User's Manual

PuriCare[®] Vertical Flow Stations

Models

3830000
3830020

To receive important product updates,
complete your product registration card
online at register.labconco.com

Please read the User's Manual before operating the equipment.

Copyright © 2018 Labconco Corporation. The information contained in this manual and the accompanying products are copyrighted and all rights reserved by Labconco Corporation. Labconco Corporation reserves the right to make periodic design changes without obligation to notify any person or entity of such change.

Warranty

Labconco Corporation provides a warranty to the original buyer for the repair or replacement of parts and reasonable labor as a result of normal and proper use of the equipment with compatible chemicals. Broken glassware and maintenance items, such as filters, gaskets, light bulbs, finishes and lubrication are not warranted. Excluded from warranty are products with improper installation, erratic electrical or utility supply, unauthorized repair and products used with incompatible chemicals.

PuriCare® Vertical Flow Stations carry a three-year warranty from date of installation or four years from date of shipment from Labconco, whichever is sooner. Warranty is non-transferable and only applies to the owner (organization) of record.

Buyer is exclusively responsible for the set-up, installation, verification, decontamination or calibration of equipment. This limited warranty covers parts and labor, but not transportation and insurance charges. If the failure is determined to be covered under this warranty, the dealer or Labconco Corporation will authorize repair or replacement of all defective parts to restore the unit to operation. Repairs may be completed by 3rd party service agents approved by Labconco Corporation. Labconco Corporation reserves the rights to limit this warranty based on a service agent's travel, working hours, the site's entry restrictions and unobstructed access to serviceable components of the product.

Under no circumstances shall Labconco Corporation be liable for indirect, consequential, or special damages of any kind. This warranty is exclusive and in lieu of all other warranties whether oral, or implied.

Returned or Damaged Goods

Do not return goods without the prior authorization from Labconco. Unauthorized returns will not be accepted. If your shipment was damaged in transit, you must file a claim directly with the freight carrier. Labconco Corporation and its dealers are not responsible for shipping damages.

The United States Interstate Commerce Commission rules require that claims be filed with the delivery carrier within fifteen (15) days of delivery.

Limitation of Liability

The disposal and/or emission of substances used in connection with this equipment may be governed by various federal, state, or local regulations. All users of this equipment are required to become familiar with any regulations that apply in the user's area concerning the dumping of waste materials in or upon water, land, or air and to comply with such regulations. Labconco Corporation is held harmless with respect to user's compliance with such regulations.

Contacting Labconco Corporation

If you have questions that are not addressed in this manual, or if you need technical assistance, contact Labconco's Customer Service Department or Labconco's Product Service Department at 1-800-821-5525 or 1-816-333-8811, between the hours of 7:30 a.m. and 5:30 p.m., Central Standard Time.

TABLE OF CONTENTS

CHAPTER 1: INTRODUCTION	1
About This Manual	1
Typographical Conventions	3
CHAPTER 2: PREREQUISITES	4
Location Requirements	5
Exhaust Requirements	5
Electrical Requirements	5
Space Requirements	6
Overhead Clearance	6
CHAPTER 3: GETTING STARTED	7
Unpacking Your Vertical Flow Station	7
PuriCare Components	8
Preparing the Station for Operation	8
Exhaust System Requirements	9
Initial Certification	9
CHAPTER 4: THEORY OF OPERATION AND SAFETY PRECAUTIONS	10
HEPA Filters	10
Directional Airflow	11
Impellers and Motor/Blower	12
Speed Controls	12
Station Air Intakes (Grilles), Ductwork & Air Balance Controls	13
Safety Precautions	13
CHAPTER 5: USING YOUR PURICARE	16
Operating the Sash	16
Working in Your PuriCare	18
CHAPTER 6: MAINTAINING YOUR PURICARE	20
Routine Maintenance Schedule	20
Service Operations	21
Downflow Velocities	24
Downflow Velocity Grid Patterns	24
Inflow Volume Calculation – Primary Method	24
Inflow Volume Calculation – Secondary Method	25
Speed Control Adjustments	25

Supply HEPA Filter Replacement	27
Exhaust HEPA Filter Replacement	28
Impeller and Motor/Blower Maintenance & Replacement	29
Diffuser Removal	30
Storage	31
CHAPTER 7: MODIFYING YOUR VERTICAL FLOW STATION	
Installing a Shelf	32
CHAPTER 8: TROUBLESHOOTING	34
APPENDIX A: VERTICAL FLOW STATION COMPONENTS	36
APPENDIX B: VERTICAL FLOW STATION DIMENSIONS	38
APPENDIX C: VERTICAL FLOW STATION SPECIFICATIONS	39
Electrical Data	39
Impeller Specifications	39
Motor Specifications	40
APPENDIX D: PURICARE ACCESSORIES	43
Shelf Kit	43
APPENDIX E: QUICK CHART FOR THE PURICARE VERTICAL FLOW STATIONS	44
APPENDIX F: REFERENCES	45

CHAPTER 1

INTRODUCTION

Congratulations on your purchase of a Labconco PuriCare Series Vertical Flow Station. Your PuriCare product is designed to protect you, your product and your laboratory environment from aerosols. It is the result of Labconco's years of experience manufacturing laboratory equipment, and many of its features were suggested to us by users like you.

The PuriCare offers many unique features to enhance safety, performance and ergonomics. To take full advantage of them, please acquaint yourself with this manual and keep it handy for future reference. If you are unfamiliar with how Vertical Flow Stations operate, please review *Chapter 4: Theory of Operation and Safety Precautions* before you begin working in the station. Even if you are an experienced user, please review *Chapter 5: Using Your Vertical Flow Station*; it describes your PuriCare's features so that you can use the station efficiently.

About This Manual

This manual is designed to help you learn how to install, use, and maintain your Vertical Flow Station. Instructions for installing optional equipment on your station are also included.

Chapter 1: Introduction provides a brief overview of the Vertical Flow Station, explains the organization of the manual, and defines the typographical conventions used in the manual.

Chapter 2: Prerequisites explains what you need to do to prepare your site before you install your Vertical Flow Station. Electrical and service requirements are discussed.

Chapter 3: Getting Started contains the information you need to properly unpack, inspect, install, and certify your Vertical Flow Station.

Chapter 4: Theory Of Operation And Safety Precautions explains how the PuriCare operates and the appropriate precautions you should take when using the station.

Chapter 5: Using Your PuriCare discusses the basic operation of your station. Information on how to prepare, use and shut down your PuriCare are included.

Chapter 6: Maintaining Your PuriCare explains how to perform routine maintenance on your Vertical Flow Station. Information on how to safely disinfect the interior of your station and replace the lamps are included.

Chapter 7: Modifying Your Vertical Flow Station describes how to install the optional equipment on the station.

Chapter 8: Troubleshooting contains a table of problems you may encounter while using your Vertical Flow Station including the probable causes of the problems and suggested corrective actions.

Appendix A: Vertical Flow Station Components contains labeled diagrams of all of its components.

Appendix B: Vertical Flow Station Dimensions contains comprehensive diagrams showing all of the dimensions for the PuriCare model.

Appendix C: Vertical Flow Station Specifications contains the electrical requirements for the Vertical Flow Station. Wiring diagrams for both the 115V and 230V models are also included.

Appendix D: PuriCare Accessories lists the part number and descriptions of all of the accessories available for your Vertical Flow Station.

Appendix E: Quick Chart for the PuriCare Vertical Flow Station provides useful operating specifications.

Appendix F: References lists the various resources available that deal with biosafety.

Typographical Conventions

Recognizing the following typographical conventions will help you understand and use this manual:

- Book, chapter, and section titles are shown in italic type (e.g., *Chapter 3: Getting Started*).
- Steps required to perform a task are presented in a numbered format.
- Comments located in the margins provide suggestions, reminders, and references.
- Critical biosafety information is presented in boldface type in paragraphs that are preceded by the biosafety icon. Failure to comply with the information following a biosafety icon may result in illness or death.



- Critical information is presented in boldface type in paragraphs that are preceded by the exclamation icon. Failure to comply with the information following an exclamation icon may result in injury to the user or permanent damage to your Vertical Flow Station.

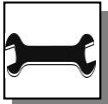

- Critical information is presented in boldface type in paragraphs that are preceded by the wrench icon. These operations should only be performed by a trained certifier or contractor. Failure to comply with the information following a wrench icon may result in injury to the user or permanent damage to your Vertical Flow Station.

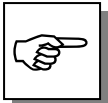

- Important information is presented in capitalized type in paragraphs that are preceded by the pointer icon. It is imperative that the information contained in these paragraphs be thoroughly read and understood by the user.

115V

230V

- Information that is specific to a particular model of Vertical Flow Station is preceded by a number icon. The 115V icon indicates the text is specific to the 115 volt models. The 230V icon indicates the text is specific to the 230 volt models.

CHAPTER 2

PREREQUISITES

Before you install your Vertical Flow Station, you need to prepare your site for installation. Carefully examine the location where you intend to install your station. You must be certain that the area is level and of solid construction. In addition, a dedicated source of electrical power must be located near the installation site.

Carefully read this chapter to learn:

- the location requirements for your installation site.
- the electrical power requirements for your installation site.
- the exhaust requirements for your installation site.
- the space requirements for your installation site.

Refer to *Appendix C: Vertical Flow Station Specifications* for complete station electrical and environmental conditions, specifications and requirements.

Location Requirements



The PuriCare should be located away from traffic patterns, doors, fans, ventilation registers, fume hoods and any other air-handling device that could disrupt its airflow patterns. All windows in the room should be closed. Figure 2-1 shows the optimum location for the PuriCare.

Figure 2-1

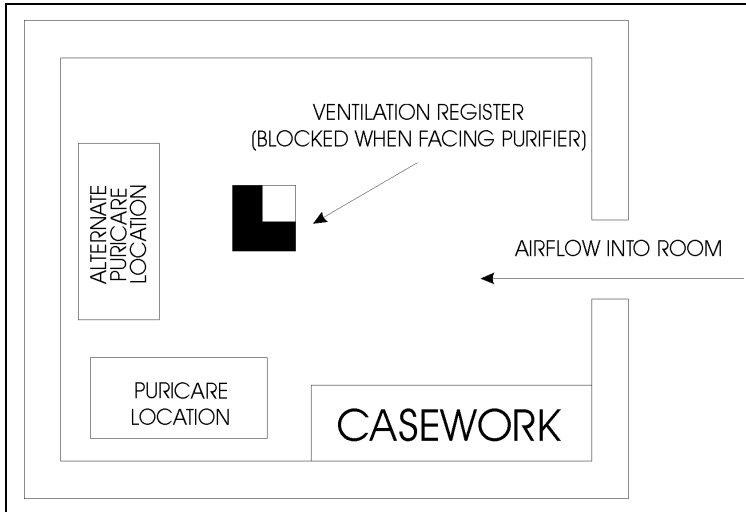

Exhaust Requirements

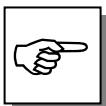

THE VERTICAL FLOW STATION DISCHARGES ITS FILTERED EXHAUST AIR UNDERNEATH THE UNIT. IT SHOULD BE PLACED AT LEAST 12 INCHES AWAY FROM ANY VERTICAL OBSTRUCTION TO OPERATE PROPERLY.

Electrical Requirements

The different PuriCare models have the following electrical requirements:

Table 2-1

Model #	Requirements
38300- 00-09	115 VAC, 60 Hz, 12 Amps
38300- 20-29	230 VAC, 50 Hz, 6 Amps

All PuriCare Stations with model numbers ending in –00 to –09 are designed for operation at 115 volts, 60Hz, alternating current. PuriCare Stations with model numbers ending in –20 to –29 are designed for operation at 230 +/- 20 volts, 50 Hz alternating current. A dedicated outlet with a circuit breaker rated at 20 Amps for 115 volt models and 10 Amps for 230 volt models, should be located within 10 feet of the station.



Always follow the plug manufacturer's instructions for the proper assembly and testing of the plug and power cord.



THE ELECTRICAL OUTLETS OF THE 115 VOLT PURICARE IS PROTECTED BY A GROUND FAULT INTERRUPTER CIRCUIT (GFIC). LABCONCO DOES NOT RECOMMEND INSTALLING A GFIC ON THE OUTLET THAT THE PURICARE PLUGS INTO.

Space Requirements

The dimensions for the different models are shown in *Appendix B: Vertical Flow Station Dimensions*.

Overhead Clearance

In order for the Vertical Flow Station to operate properly, at least six inches (150 mm) clearance from any overhead obstructions is required when the station is in its final operating position.

CHAPTER 3

GETTING STARTED

Now that the site for your Vertical Flow Station is properly prepared, you are ready to unpack, inspect, install, and certify it. Read this chapter to learn how to:

- unpack and move your PuriCare.
- set up the station.
- connect the electrical supply source.
- arrange certification.

Depending upon which model you are installing, you may need common tools in addition to a 3/4" wrench, a flat-blade screwdriver, and a Phillips screwdriver.



The PuriCare models weigh approximately 450 lbs. (205 kg). The carton allows for lifting with a mechanical lift truck or floor jack.

Unpacking Your Vertical Flow Station

The United States Interstate Commerce Commission rules require that claims be filed with the delivery carrier within fifteen (15) days of delivery.

Carefully unpack your PuriCare and inspect it for damage that may have occurred in transit. If your unit is damaged, notify the delivery carrier immediately and retain the entire shipment intact for inspection by the carrier.

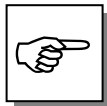

DO NOT RETURN GOODS WITHOUT THE PRIOR AUTHORIZATION OF LABCONCO. UNAUTHORIZED RETURNS WILL NOT BE ACCEPTED.

IF YOUR STATION WAS DAMAGED IN TRANSIT, YOU MUST FILE A CLAIM DIRECTLY WITH THE FREIGHT CARRIER. LABCONCO CORPORATION AND ITS DEALERS ARE NOT RESPONSIBLE FOR SHIPPING DAMAGES.

Do not discard the carton or packing material for your PuriCare until you have checked all of the components and installed and tested the unit.



Do not remove the PuriCare from its shipping skid until it is ready to be placed into its final location. Move the unit by placing a flat, low dolly under the shipping skid, or by using a floor jack.

Do not move the station by tilting it onto a hand truck.

PuriCare Components

Labconco manufactures Vertical Flow Stations for use with 115 volts or 230 volts.

Locate the station model you received in the following group of tables. Verify that the components listed are present and undamaged.

Catalog #	PuriCare Description
3830000	Vertical Flow Station, 115 VAC, 60 Hz
3830020	Vertical Flow Station, 230 VAC, 50 Hz

Plus the Following:

Part #	Component Description
3794300	User's Manual
	Power Cord
	(4) Caster Wheels
	(8) Washers
	(4) Lock Washers
	(4) Acorn Nuts

If you did not receive one or more of the components listed for your PuriCare, or if any of the components are damaged, contact Labconco Corporation immediately for further instructions.

Preparing the Station for Operation

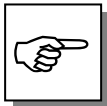

ASSEMBLY INSTRUCTIONS FOR THE STATION (LABCONCO P/N 1058300) ARE ATTACHED TO THE SASH OF THE PURICARE. IF THESE INSTRUCTIONS ARE MISSING OR UNCLEAR, CONTACT LABCONCO AT 800-821-5525.

Exhaust System Requirements

The Vertical Flow Station discharges its HEPA filtered exhaust air beneath the unit.



Maintain at least 12 inches clearance between the station and any vertical obstruction on all sides of the unit.

Initial Certification

Prior to use, all PuriCare stations should be certified by a qualified certifier. Under normal operating conditions, the PuriCare stations should be recertified at least annually or when serviced. The certifier should perform the following tests:

- HEPA Filter Leak Tests
- Downflow Velocity Profile Test*
- Inflow Volume Test
- Airflow Smoke Patterns

*There is no tolerance on the downflow profile values.

If you have any questions regarding certification agencies or need assistance in locating one, contact Labconco's Product Service Department at 1-800-522-7658 or 816-333-8811.

CHAPTER 4

THEORY OF OPERATION AND SAFETY PRECAUTIONS

The Vertical Flow Station operates using the following principles:

- Filtration and retention of particulates by High Efficiency Particulate Air (HEPA) filters Directional airflow

The major components in the Vertical Flow Station are:

- The HEPA filters
- The impellers and motor/blower to force air through the unit
- A speed controls for the impellers and motor
- Station air intakes (grilles)

HEPA Filters

HEPA filters are disposable, dry-type particulate filters. The filter material or media is typically made of borosilicate microfibers that are made into a thin sheet, in a process similar to the production of paper. This sheet is folded, or pleated to increase its surface area. The pleats are held in place by aluminum diffusers or by beads of glue that add rigidity to the media pack. The media pack is then set into a suitable frame, and the perimeter sealed to the filter frame, as shown in Figure 4-1.

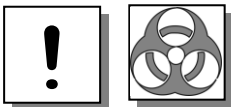

The HEPA filter media is very fragile. Do not touch or contact the media surface. If you think the surface of a HEPA filter is damaged, DO NOT USE THE STATION. Have the HEPA filter integrity tested by a qualified certifier before using the station.



HEPA Filters are only effective against particulate material. Gases will pass through the filter.

Figure 4-1

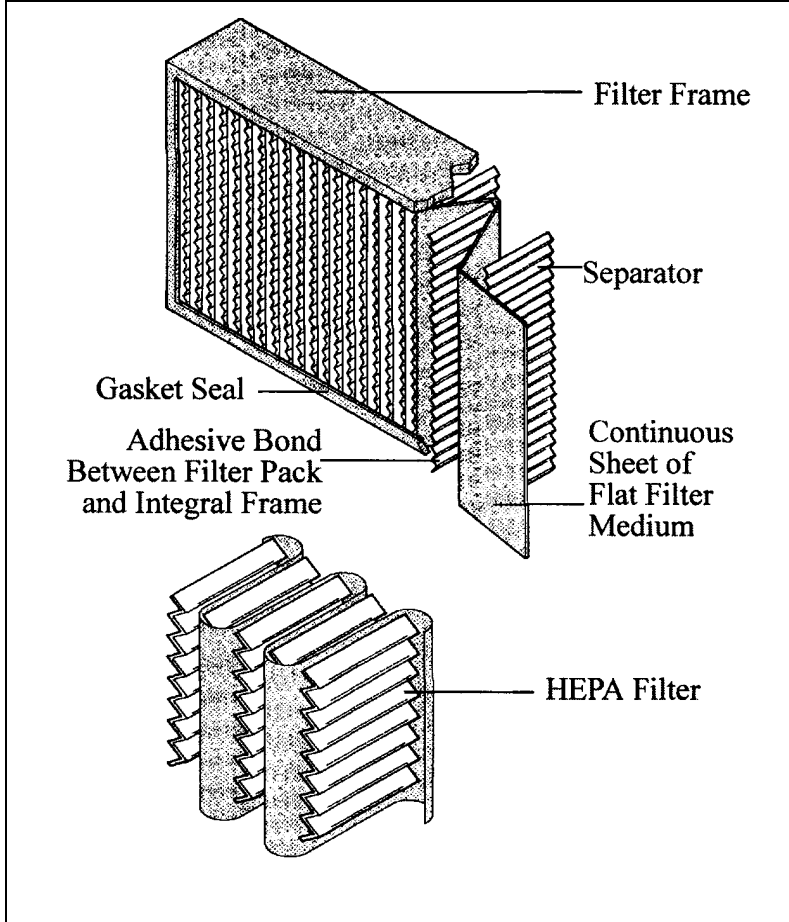

Directional Airflow

Directional airflow plays a key role in the Vertical Flow Station's performance. Sterile, HEPA filtered air flows downward throughout the work area, protecting the animals inside from external and cross contamination. All of this "supply" air and some room air is drawn into the front of the station at the grille. This "curtain" of air makes it difficult for aerosols to escape out of the work area and into the outside environment.

Figure 4-2

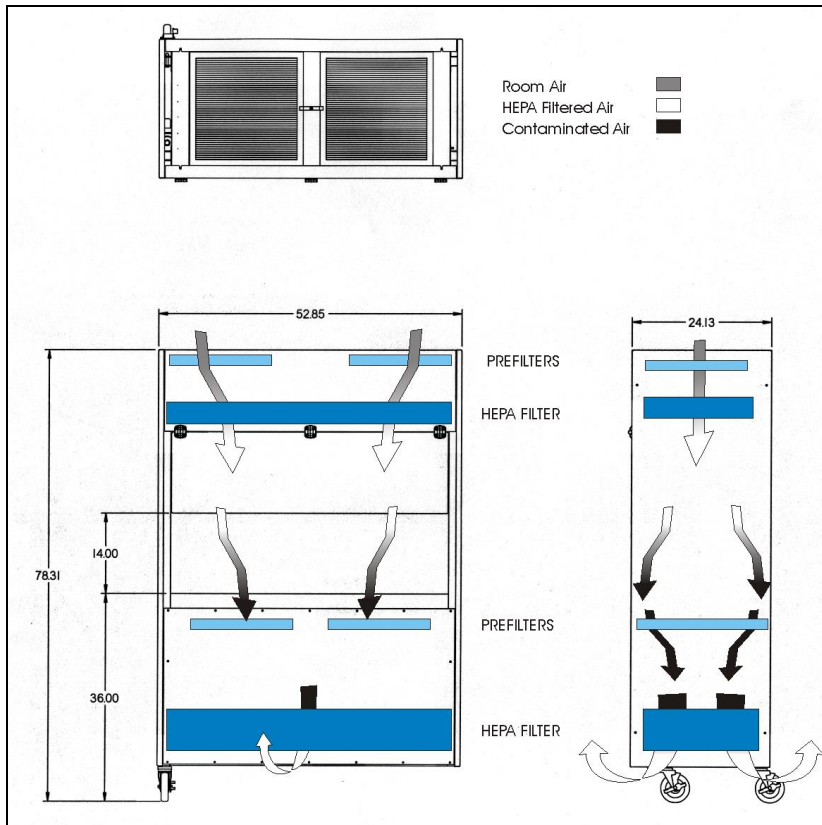

Impellers and Motor/Blower

The Vertical Flow Station uses two air handling systems to direct air through it. In the top of the station twin motorized impellers draw room air in through prefilters and then force the air through the upper (supply) HEPA filter. Below the worksurface there are another set of prefilters, a heavy duty motor blower and the exhaust HEPA filter.

Speed Controls



The speed controls should only be adjusted by a qualified certifier.

The speed controls are electronic circuits that allow the certifier to set the speed of the motors by adjusting their voltage. The PuriCare speed controls are rated for 10 Amps current each, far in excess of the motor's normal current draw, to allow for greater reliability.

Station Air Intakes (Grilles), Ductwork and Air Balance Controls

The station's containment and performance are affected by the location, size, and pattern of the grilles at the front and rear of the work area.



Never block or obstruct the grilles of the PuriCare.

The internal ductwork of the PuriCare conveys the air from the work area to the blower, and then from the blower to the filters. The exhaust filter plenum of the PuriCare is unique in the industry, utilizing perfect manifold technology to deliver a more uniform airflow to the exhaust HEPA filter, optimizing filter loading and operational life.

Safety Precautions



The PuriCare Vertical Flow Station is NOT a biosafety cabinet. Do not use this device for the containment of biohazardous, toxic, flammable, or explosive materials. If you have questions regarding the operation of this device, contact Labconco at 800-821-5525 or www.labconco.com.



HEPA filters are only effective for the entrapment of particulate matter. Manipulations which generate gases or vapors, i.e., toxic chemicals or radionuclides, should not be performed in this station.



The PuriCare Vertical Flow Station should be certified by a qualified certification technician before its initial use. The station should be recertified whenever it is relocated, serviced or at least annually thereafter.



Some components of the PuriCare Vertical Flow Station should only be serviced by a qualified certification technician. Some internal components of the PuriCare may become contaminated with allergenic materials during operation of the unit. Only experienced personnel competent in decontamination procedures should decontaminate the station before servicing contaminated components. If you have any questions regarding certification agencies, or need assistance in locating one, contact Labconco's Product Service Department at 800-522-7658 or 816-333-8811.

Ensure that the unit is connected to electrical service in accordance with local and national electrical codes. Failure to do so may create a fire or electrical hazard. Do not remove or service any electrical components without first disconnecting the PuriCare from electrical service.

Avoid the use of flammable gases or solvents in the PuriCare. Care must be taken to ensure against the concentration of flammable or explosive gases or vapors. An open flame should NOT be used in the PuriCare. Open flames may disrupt the airflow patterns in the station, burn the HEPA filter and/or damage the filter's adhesive. Gases under high pressure should not be used in the PuriCare station, as they may disrupt the airflow patterns of the station.

The surface of the HEPA filters are fragile and should not be touched. Care must be taken to avoid puncturing either HEPA filter during installation or normal operation. If you suspect that a HEPA filter has been damaged, DO NOT use the station; contact a local certification agency or Labconco at 800-821-5525 or 816-333-8811 for recertification information.

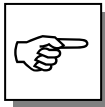

THE HEPA FILTERS IN THE PURICARE STATION WILL GRADUALLY ACCUMULATE AIRBORNE PARTICULATE MATTER FROM THE ROOM AND FROM WORK PERFORMED IN THE STATION. THE RATE OF ACCUMULATION WILL DEPEND UPON THE CLEANLINESS OF THE ROOM AIR, THE AMOUNT OF TIME THE STATION IS OPERATING AND THE NATURE OF WORK BEING DONE IN THE STATION.



Proper operation of the station depends largely upon the station's location and the operator's work habits. Consult the *Installation and Normal Operation* sections of this manual for further details.

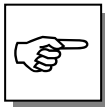

WHEN SURFACE DISINFECTING THE PURICARE STATION:

- AVOID SPLASHING THE DISINFECTING SOLUTION ON SKIN OR CLOTHING.
- ENSURE ADEQUATE VENTILATION.
- CAREFULLY FOLLOW THE MANUFACTURER'S SAFETY INSTRUCTIONS WHEN HANDLING DISINFECTANTS AND ALWAYS DISPOSE OF DISINFECTING SOLUTIONS IN ACCORDANCE WITH LOCAL AND NATIONAL LAWS.

DO NOT ALLOW DISINFECTANTS WITH FREE CHLORINE TO CONTACT THE STAINLESS STEEL COMPONENTS OF THE PURICARE FOR A LONG PERIOD OF TIME. FREE CHLORINE WILL CORRODE STAINLESS STEEL AFTER EXTENDED CONTACT.



The electrical receptacle cover, because of its construction, may be difficult to surface decontaminate. In the event of gross contamination, the cover should be removed, sterilized and/or decontaminated as required and discarded. The receptacle cover should then be replaced with the repair part listed in *Appendix A: PuriCare Components*.

CHAPTER 5

USING YOUR PURICARE

Operating the Sash

The sash of the Vertical Flow Station can be locked in the full open position. To lock the sash open:

1. Grasp the bottom edge of the sash, and pivot it up until the sash is fully opened.
2. Locate the sash locking bolt on the inside left side of the sash, as shown in Figure 5-1.
3. Restrain the sash by aligning the bolt with the hole in the left side wall of the station, and pressing the bolt to the left until it engages the hole.
4. To release the sash, support the bottom edge while pulling the bolt to the right. Allow the sash to pivot down to its closed position, ensuring that the sash is set in the closed position.

Figure 5-1

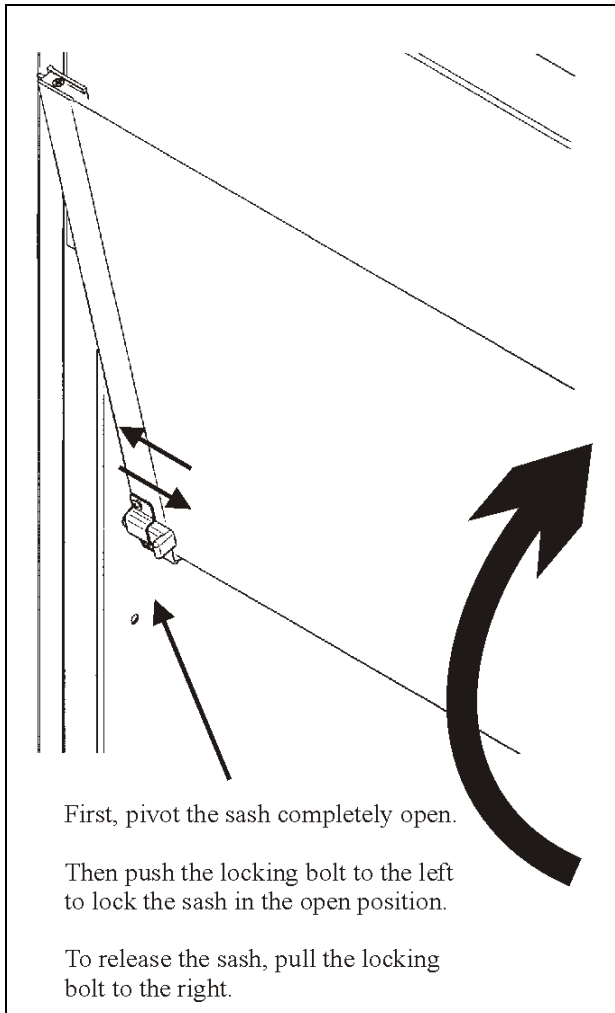

The sash must be completely closed for the PuriCare to contain properly.

5. Turn the blower and light switches to the 'On' position, as shown in Figure 5-2.

Figure 5-2

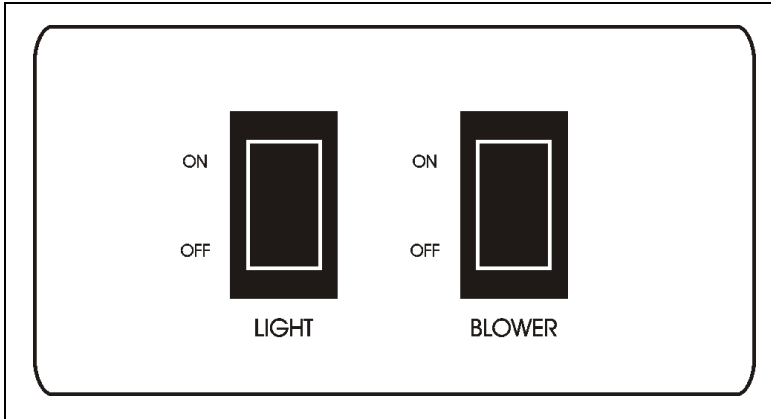

Working In Your PuriCare

Planning

- Thoroughly understand procedures and equipment required before beginning work.
- Arrange for minimal disruptions, such as room traffic or entry into the room while the station is in use.

Start-up

- Turn on fluorescent light and station blower.
- Check the return air grilles for obstructions, and note the pressure gauge reading.
- Allow the station to operate unobstructed for 5 minutes.
- Wash hands and arms thoroughly with germicidal soap.
- Wear a long sleeved lab coat with knit cuffs and over-the-cuff rubber gloves. Use protective eyewear. Wear a protective mask if appropriate.

Wipe-Down

- Pivot the sash to its full open position.
- Wipe down the interior surfaces of the station with 70% ethanol, or a suitable disinfectant, and allow to dry.
- Slowly close the sash.

Loading Materials and Equipment

- Only load the materials required for the procedure. Do not overload the station.
- Do not obstruct the grilles on the front, back or sides of the work area.
- Large objects should not be placed close together.

Work Techniques

- Keep all materials at least 4 inches inside of the sash, and perform all contaminated operations as close to the center of the work area as possible.
- Segregate all clean and contaminated materials in the work area.
- Arrange materials to minimize the movement of contaminated materials into clean areas.
- Keep all discarded contaminated material to one zone work area.
- Avoid the use of an open flame.
- Use proper aseptic technique.
- Avoid using techniques or procedures that disrupt the airflow patterns of the station.
- If there is a spill or splatter during use, all objects in the station should be surface decontaminated before removal. Thoroughly disinfect the working area of the station WHILE IT IS STILL IN OPERATION. This will prevent the release of contaminants from the station.

Final Purging

- Upon completion of work, the station should be allowed to operate for two to three minutes undisturbed, to purge airborne contaminants from the work area.

Unloading Materials and Equipment

- Objects in contact with contaminated material should be surface decontaminated before removal from the station.
- All open trays or containers should be covered before being removed from the station.

Wipe-Down

- Wipe down the interior surfaces of the station with 70% ethanol, or a suitable disinfectant, and allow to dry.
- Periodically lift the work surface and wipe down the area beneath it.
- Inspect the prefilters located beneath the work surface, beneath the work pan. Replace them if necessary
- Dispose of rubber gloves appropriately, and have lab coat laundered properly.
- Wash hands and arms thoroughly with germicidal soap.

Shutdown

- Turn off the fluorescent light and station blower, close the sashes.

CHAPTER 6

MAINTAINING YOUR

PURICARE

Now that you have an understanding of how to work in the Vertical Flow Station, we will review the suggested maintenance schedule and the common service operations necessary to maintain your PuriCare for peak performance.



Many of the service operations should be performed only by trained and experienced certification technicians after the station has been properly decontaminated. DO NOT attempt to perform these operations if you are not properly trained. The service operations that require qualified certifiers are preceded by the wrench icon.

Routine Maintenance Schedule

Weekly

- Using 70% ethanol, or a suitable disinfectant, surface disinfect the inside of the station, and the work surface.
- Using an appropriate optical glass cleaner and cloth, clean the sash.
- Operate the station blowers, noting the pressure readings in an operational log.
- Lift the work surface and inspect the prefilters.

Monthly (or more often as required)

- Using a damp cloth, clean the exterior surfaces of the station, particularly the front, back and top of the unit, to remove any accumulated dust.
- Disinfect and lift the work surface. Surface disinfect the lower plenum with a solution of 70% ethanol, or a suitable disinfectant. Check the prefilters for retained materials.
- Replace the prefilters as needed.
- All weekly activities.

Annually

- Have the station recertified by a qualified certification technician.
- All monthly activities.

Biannually

- Replace the fluorescent lamp.

Service Operations

Work Surface Removal:

1. Loosen and remove the three thumbscrews located at the front of the work surface. Only loosen the three thumbscrews on the back of the work surface.
2. Lift the front edge of the work surface up and pull it out of the station work area.

Prefilter Removal and Cleaning:



The prefilters may be contaminated with allergenic material. Take appropriate precautions when removing and handling the prefilters to prevent exposure. The prefilters are disposable and cannot be cleaned.

Upper Prefilter Removal:

1. Loosen the nuts that secure the two upper prefilter brackets as shown in Figure 6-1.
2. Swing the upper prefilter brackets until the prefilters can be lifted out of the top of the units.
3. Replace the prefilter elements, ensuring the air flow direction arrow on the prefilter frame points down.

Figure 6-1

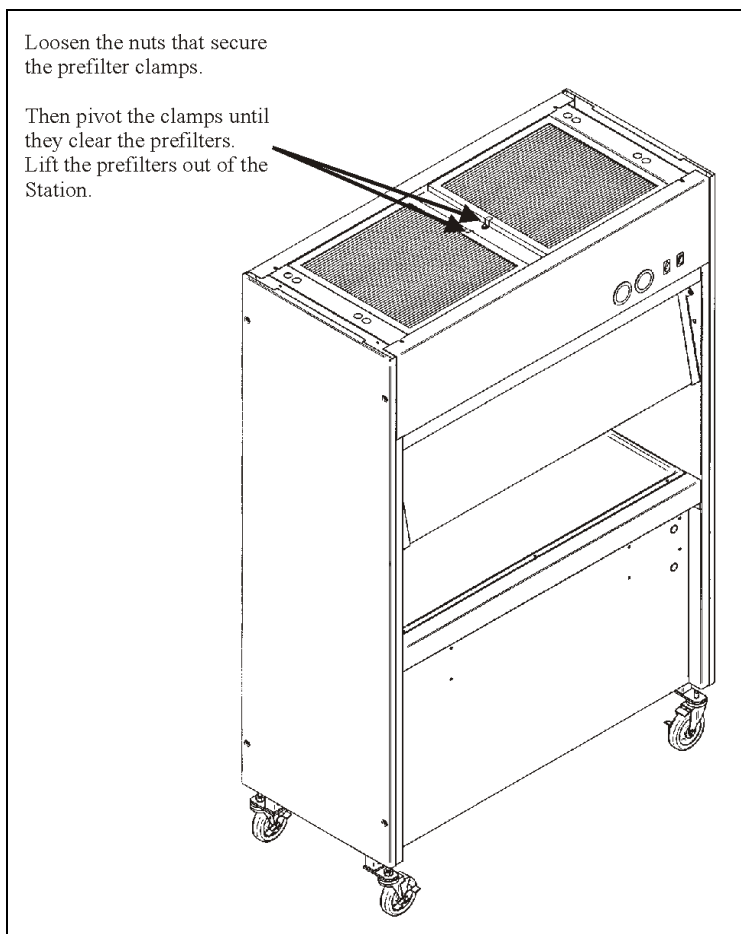

Lower Prefilter Removal:

1. Remove the work surface as described earlier.
2. Loosen the nuts that secure the two lower prefilter brackets as shown in Figure 6-2.
3. Swing the lower prefilter brackets until the prefilters can be lifted out of the unit.
4. Replace the prefilter elements, ensuring the air flow direction arrow on the prefilter frame points down.

Figure 6-2

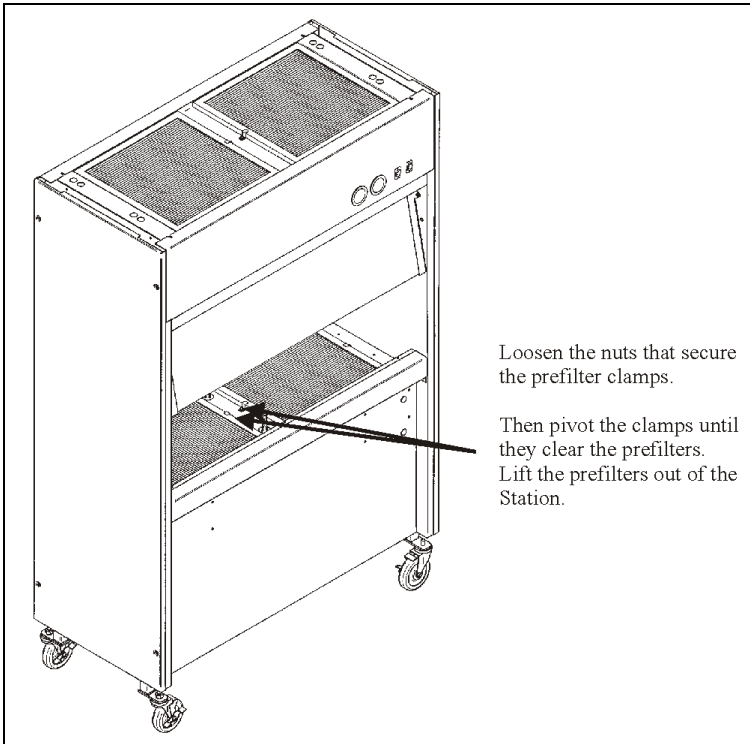

Changing the Fluorescent Lamp:

1. Unplug the station.
2. Swing up the sash.
3. Remove the fluorescent lamp by rotating it 90 degrees and pulling it straight down and out of its sockets.
3. Install the new lamp by reversing the removal procedure.



THE LAMP(S) IN THIS PRODUCT CONTAIN MERCURY

Manage in accordance with local disposal laws. DO NOT place lamps in trash. Dispose as a hazardous waste. For information regarding safe handling, recycling and disposal, consult www.lamprecycle.org

CETTE LAMPE DANS CE PRODUIT CONTIENT DU MERCURE

Éliminez ou recyclez conformément aux lois applicables. Pour de l'information concernant des pratiques de manipulation sécuritaires et l'élimination sécuritaire et le recyclage, veuillez consulter www.lamprecycle.org

Resetting a Circuit Breaker:

To reset any of the circuit breakers located on the back of the unit near the power cord outlet, depress the white button until it sets.



The service operations listed in the rest of this chapter should only be performed by a qualified certifier.

Downflow Velocities

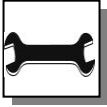

The average downflow velocity for all Vertical Flow Stations should be set at 50-55 FPM.

Downflow Velocity Grid Patterns

The downflow velocity test grid for all Vertical Flow Stations is as follows:

The perimeter of the down test grid is 6.00 inches from the side walls and 6.00 from the rear of the work area. The grid consists of three rows, 5.95 inches apart, from the back to the front, with eight test points on each row, spaced 5.21 inches apart. All points are read at the bottom edge of the sash.

Inflow Volume Calculation - Primary Method

The Inflow Volume can be measured directly, using a Direct Inflow Measurement (DIM) meter, using the following method:

1. Turn the station off and raise the sash.
2. Remove the work surface and the lower prefilters as described earlier.
3. Using rigid cardboard, or fiberboard, cut two patterns as shown in Figure 6-3.
4. Place the solid pattern over the prefilter hole directly above the blower. Seal the pattern to the prefilter shelf with duct tape if necessary.
5. Place the pattern with the hole over the other prefilter hole. Seal the pattern to the prefilter shelf if necessary.
6. Place the DIM upside down over the hole in the second pattern. Seal the DIM to the pattern with duct tape if necessary.
7. Start the Station and let it run for at least two minutes. Turn on the DIM and take at least 10 readings of the inflow volume. Average the readings.
8. The average inflow volume, corrected for local conditions, should be 650-670 CFM.

Figure 6-3

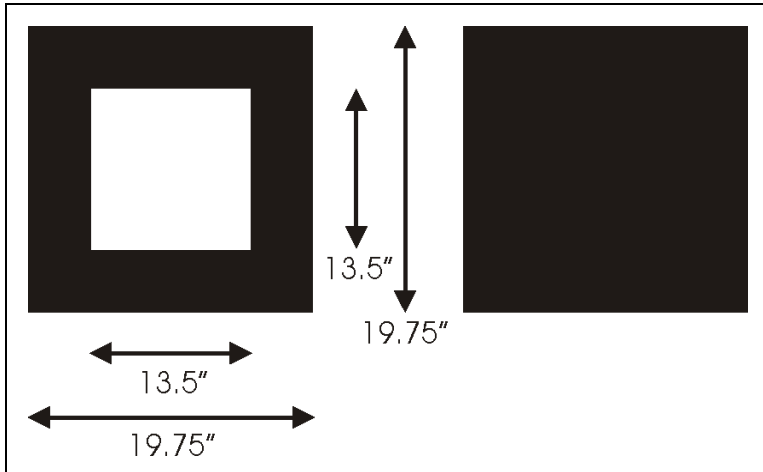

Inflow Volume Calculation - Secondary Method

1. Turn the station off and raise the sashes.
2. Remove the work surface and the lower prefilters as described earlier.
3. Using rigid cardboard or fiberboard, cut a 20 inch square.
4. Use the square to cover the prefilter hole directly above the blower.
5. At the other prefilter hole, mark a test grid at 4 ½ inch intervals around the perimeter of the hole, establishing a 16 square grid in the hold.
6. Using a thermal anemometer, measure the velocity at the center of each of the squares.
7. Average the readings. Multiply the average velocity by the correction factor 2.25 to obtain the average inflow volume.
8. The average inflow volume, corrected for local conditions, should be 650-670 CFM.

Speed Control Adjustments

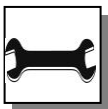

The Vertical Flow Station blower speeds should only be adjusted by a qualified certification technician. Adjustment of the impeller and/or blower speeds will affect the containment of the unit.



The Vertical Flow Station uses two independent speed controls to control the upper impellers (Supply Air) and the lower Motor/Blower (Exhaust Air)

1. Locate the two plugged speed control access holes located on the lower front panel as shown in Figure 6-4.
2. Gently pry out the chrome plugs to gain access to the speed control adjustment screws. The screw on the bottom controls the lower Motor/Blower, the one on the top controls the upper impellers.
3. Turn the screw(s) counterclockwise to increase the speed, clockwise to decrease it.



Turning the speed control adjustment screw all the way counterclockwise will shut the speed control circuit off and the motor(s) will stop. If this occurs, turn the screw clockwise until the motor(s) start running again.

4. After adjusting the appropriate speed control, measure the downflow velocities or Inflow Volume as needed.

Figure 6-4

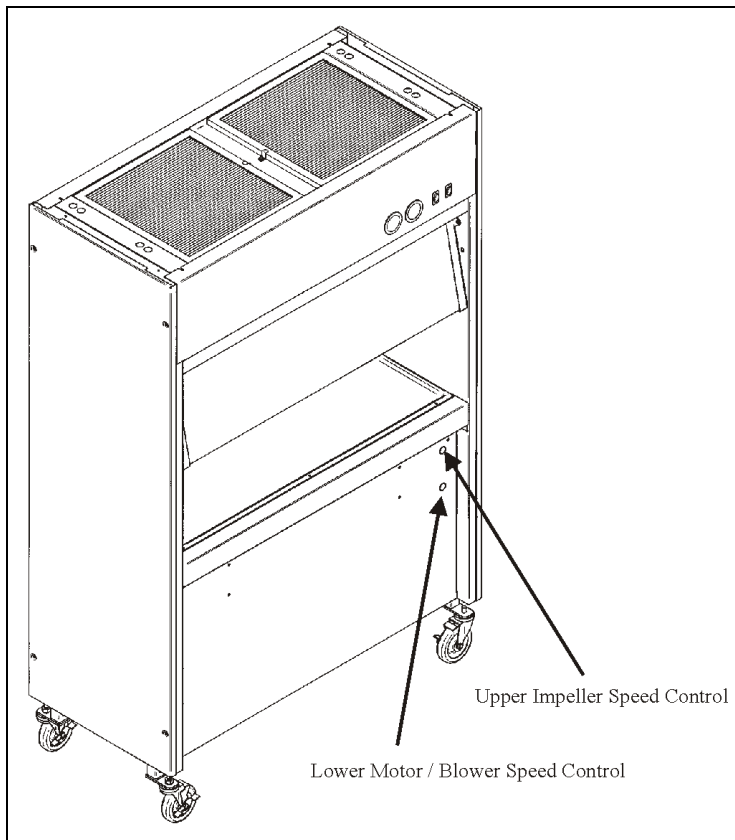

Supply HEPA Filter Replacement



The HEPA filters should only be serviced by a qualified certification technician. Following replacement of a HEPA filter, the station MUST be recertified by a qualified certification technician.

1. Unplug the station.
2. Remove the two upper prefilters as described earlier in this chapter.
3. Remove the five screws that secure the upper rear panel as shown in Figure 6-5.
4. Carefully swing the rear panel out.
5. Locate the four locking bolts that secure the upper plenum. They are located in each corner of the plenum, and they thread through the upper bracket and down onto the top of the plenum. Loosen each bolt at least $\frac{1}{2}$ inch.
6. Locate the four plenum lift bolts that raise the upper plenum. They are located in each corner of the plenum, next to the locking bolts, and they thread into the top of the plenum. Tighten each bolt until there is approximately $\frac{1}{4}$ inch clearance between the top of the HEPA filter and the bottom of the plenum.
7. Slide the Supply HEPA filter straight out of the station.
8. Ensure the replacement HEPA filter matches the performance specifications of the original filter, in particular the efficiency and the flow rate at a given pressure drop.
9. Install the replacement HEPA filter by reversing the disassembly steps.
10. Plug in the station and have it recertified before use.

Figure 6-5

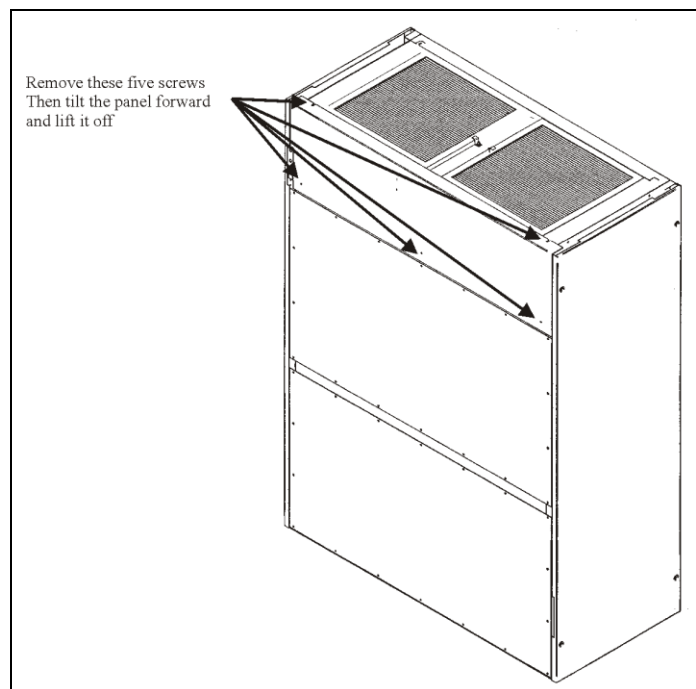

To Remove the Exhaust HEPA Filter:



The exhaust HEPA filter is awkward to handle and heavy. Use appropriate lifting techniques to remove and handle it. Use two people to remove the filter if possible.

Exhaust HEPA Filter Replacement

1. Remove the lower rear panel by removing the #2 Phillips screws on the perimeter of the panel.
2. Remove the work surface and two lower prefilters as described earlier in this chapter.
3. Locate the four locking bolts that secure the lower plenum. They are located in each corner of the plenum and they thread through the lower bracket and down onto the top of the plenum, as shown in Figure 6-6. Loosen each bolt at least ½ inch.
4. Locate the four plenum lift bolts that raise the lower plenum. They are located in each corner of the plenum, next to the locking bolts and they thread into the top of the plenum. Tighten each bolt until there is approximately ¼ inch clearance between the top of the HEPA filter and the bottom of the plenum.
5. Remove the two filter retainer brackets.
6. Slide the Exhaust HEPA filter straight out of the station.
7. Ensure the replacement HEPA filter matches the performance specifications of the original filter, in particular the efficiency and the flow rate at a given pressure drop.
8. Install the replacement HEPA filter by reversing the disassembly steps.
9. Plug in the station and have it recertified before use.

Figure 6-6

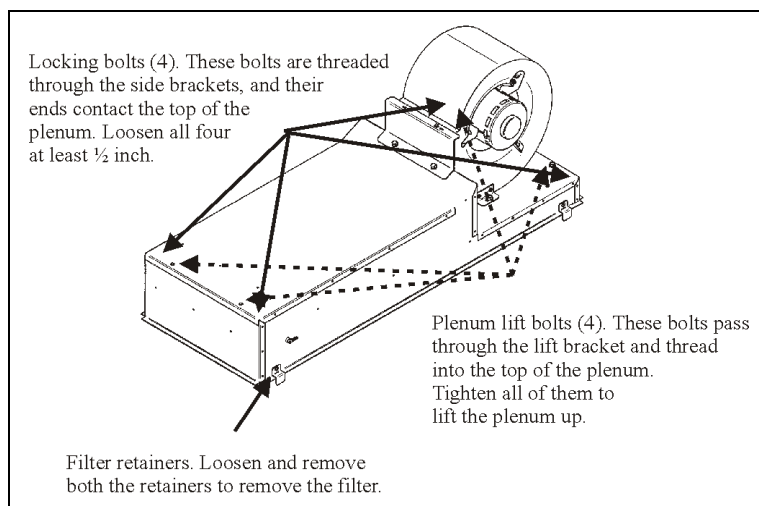

Impeller and Motor/Blower Maintenance and Replacement

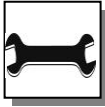

The motor/blower should be serviced by a qualified certification technician.

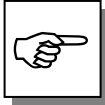

The stations blower motor and impeller bearings are sealed and require no lubrication. **DO NOT** attempt to lubricate them.

To replace an Impeller:

1. Unplug the unit.
2. Remove the two upper prefilters as described earlier in this chapter.
3. Remove the five screws that secure the upper rear panel as shown in Figure 6-5.
4. Carefully swing the upper rear panel forward.
5. Locate the four locking bolts that secure the upper plenum. They are located in each corner of the plenum, and they thread through the upper bracket and down onto the top of the plenum. Loosen each bolt as far as it will go.
6. Locate the four plenum lift bolts that raise the upper plenum. They are located in corner of the plenum next to the locking bolts, and they thread into the top of the plenum. Tighten each bolt until the top of the plenum contacts the lift brackets.
7. Slide the Supply HEPA filter straight out of the station.
8. Disconnect the wiring for the impeller to be replaced.
9. Remove the four 1/4 inch bolts and nuts that secure the impeller bracket to the plenum. Remove the impeller/bracket assembly.
10. Remove the impeller from the bracket by removing the four 5 mm screws that secure the impeller to the bracket.
11. Install the new impeller by reversing the disassembly steps.

To replace the Lower Motor/Blower:

1. Unplug the station.
2. Remove the lower rear panel.
3. Using a screwdriver, disconnect the motor ground wire from the blower housing.
4. Disconnect the motor leads from the wiring harness by pulling apart each of the 4 connectors.
5. Using a 1/2-inch wrench, remove the two upper and one lower blower mounting bolts, as shown in Figure 6-7.



The motor/blower assembly is heavy. Handle with care.

6. While supporting the blower assembly, pull the assembly straight out the plenum.
7. To replace the motor/blower assembly, reverse the above procedure. Before installing the lower rear panel, ensure that the motors rotate in the correct direction when turned on.
8. Plug in the station and have it recertified before use.

Figure 6-7

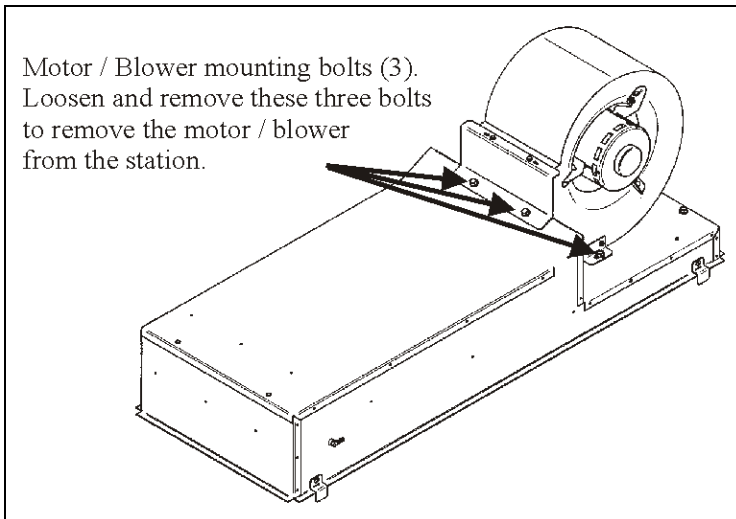

Diffuser Removal



Bending or distorting the diffuser may affect the airflow in the station. Use care when handling it.

Upper Diffuser Removal

1. Swing the sash up until it is in the locked position.
2. Locate and remove the four acorn nuts that secure the upper diffuser brackets to the station. Support the diffuser when removing the brackets and lower the diffuser straight down.

Lower Diffuser Removal

1. Locate and remove the six screws that secure the lower diffuser to the station, starting with the corner screws. Support the diffuser when removing the last two center screws and lower the diffuser straight down.

Storage

If the PuriCare is to be left unused for more than one month, the unit should be prepared for storage.



The station should not be stored in areas of excess humidity or temperature extremes. If the station is moved during storage, it must be recertified before use.

1. Lower the sashes completely and seal work area, the bottom edge and the exhaust outlet with plastic sheeting.
2. Unplug the unit.
3. Ensure that the station will not be moved or disturbed while in storage.

CHAPTER 7

MODIFYING YOUR VERTICAL FLOW STATION

Installing a Shelf

1. Ensure that the shelf kit you have is the proper one. Kits for mounting on the operator's left side are #3794900. Kits for mounting the shelf on the operator's right side are #3794901.
2. Remove the four plastic plugs on the appropriate side of the lower panel, as shown in figure 7-1.
3. Lower the shelf brackets on the shelf and align them with the holes in the panel.
4. Secure the shelf to the panel using the four screws included in the shelf kit.
5. Identify which bracket has the trigger to release the shelf from its upright position. Remove the adhesive backing of the white plastic dot included in the shelf kit.
6. Place the dot on the lower panel, 1 ½ inches directly below the bottom of the bracket with the trigger. This will prevent the trigger from scratching the lower panel.

Figure 7-1

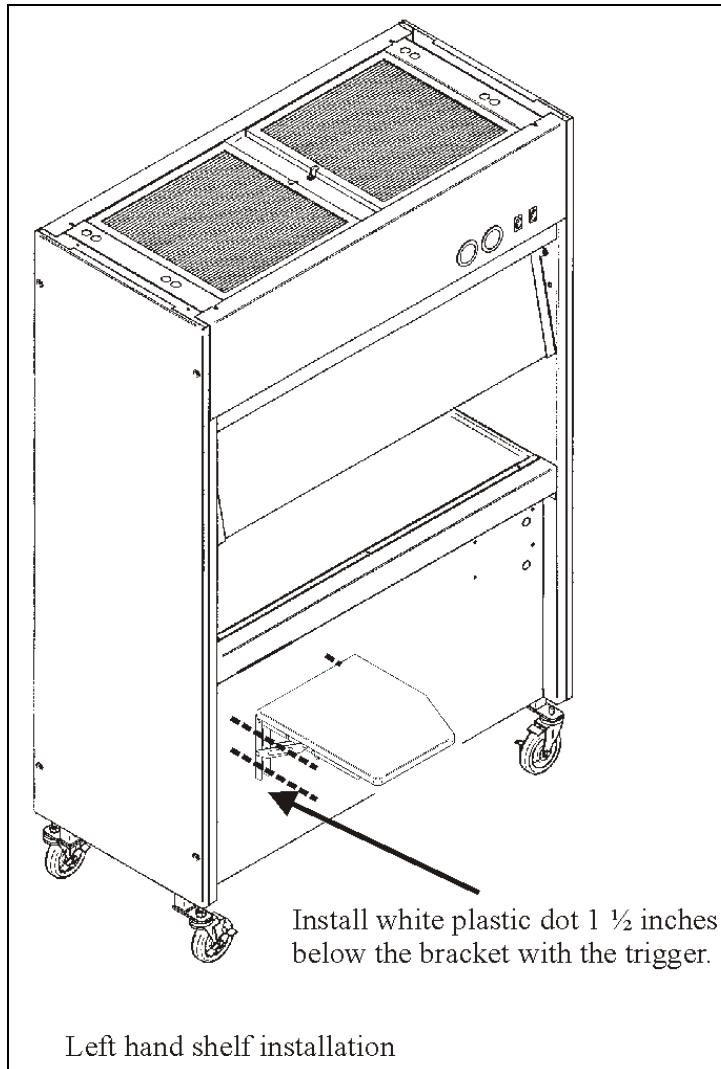

CHAPTER 8

TROUBLESHOOTING

Refer to the following table if your Vertical Flow Station fails to operate properly. If the suggested corrective actions do not solve your problem, contact Labconco for additional assistance.

PROBLEM	CAUSE	CORRECTIVE ACTION
Station blower and lights won't turn on	Unit not plugged into outlet	Plug the PuriCare into appropriate electrical service.
	Circuit breakers tripped	Reset circuit breakers.
Blower(s) won't turn on but lights work	Blower(s) wiring is disconnected	Inspect blower(s) wiring.
	Blower(s) motor is defective	Replace blower(s) motor.
Station blower turns on but lights don't work	Lamp(s) not installed correctly	Inspect lamp installation.
	Lamp is defective	Replace lamp.
	Lamp wiring is disconnected	Inspect lamp wiring.
	Defective lamp ballast	Replace lamp ballast.

PROBLEM	CAUSE	CORRECTIVE ACTION
Slight increase in pressure reading	HEPA filter loading	The pressure reading will steadily increase as the unit is used.
	Prefilter loading	Check the prefilters for obstruction(s). Clean if necessary.
	Blockage or restriction under the work surface	Ensure that the plenum beneath the work surface is unobstructed.
	Blockage of the exhaust outlet	Ensure that the exhaust outlet is not blocked or restricted.
Contamination of work in the station	Improper technique or procedure for the Vertical Flow Station	See “Use of the Vertical Flow Station” section in the manual.
	Restriction of the grille – blockage of the exhaust outlet	Ensure that all return air slots, grilles and the exhaust outlet are unobstructed.
	External factors are disrupting the station’s airflow patterns or acting as a source of contamination	See “Installation” section of this manual.
	Station is out of adjustment/HEPA filter(s) are defective	Have station recertified.

APPENDIX A

VERTICAL FLOW STATION

COMPONENTS

Illustration A-1 indicates the location of the following service parts:

Vertical Flow Station Replacement Parts

Item	Quantity	Part No.	Description
1	2	3717400	Impeller, 115 Volt
1A	2	3717500	Impeller, 230 Volt
2	1	3803100	Supply HEPA Filter
3	1	1211200	Motor, 115 VAC 4-foot
3A	1	1210502	Motor, 230 VAC 4-foot
4	1	3731101	Motor/Blower Assembly, 115 VAC 4-foot
4A	1	3751901	Motor/Blower Assembly, 230 VAC 4-foot
5	1	3759600	Exhaust HEPA Filter
6	4	3789300	Prefilter
7	2	9721900	Lamp, Fluorescent (not shown)
8	2	1287900	Receptacle Cover (not shown)

A-1

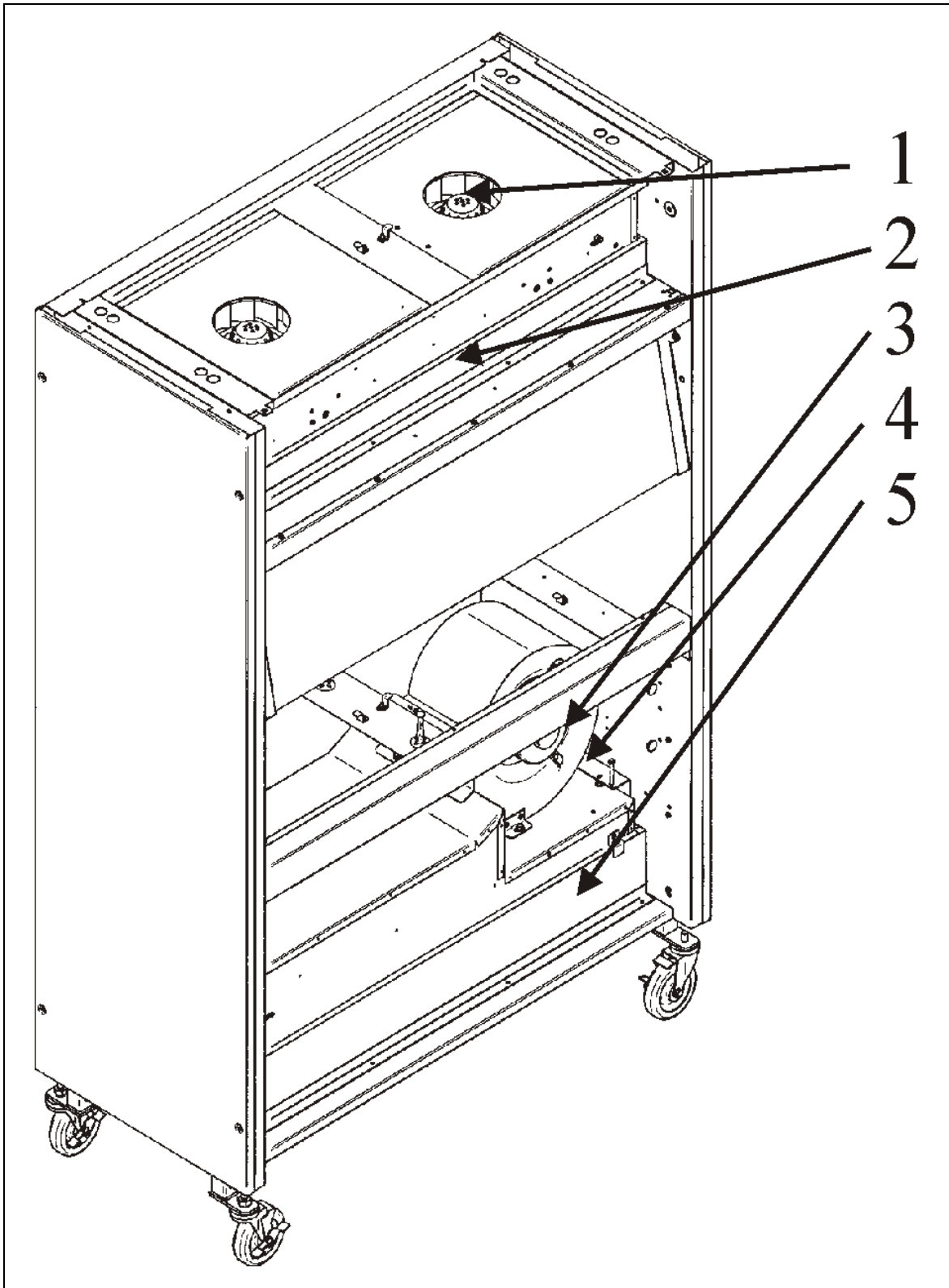

APPENDIX B

VERTICAL FLOW STATION

DIMENSIONS

B-1

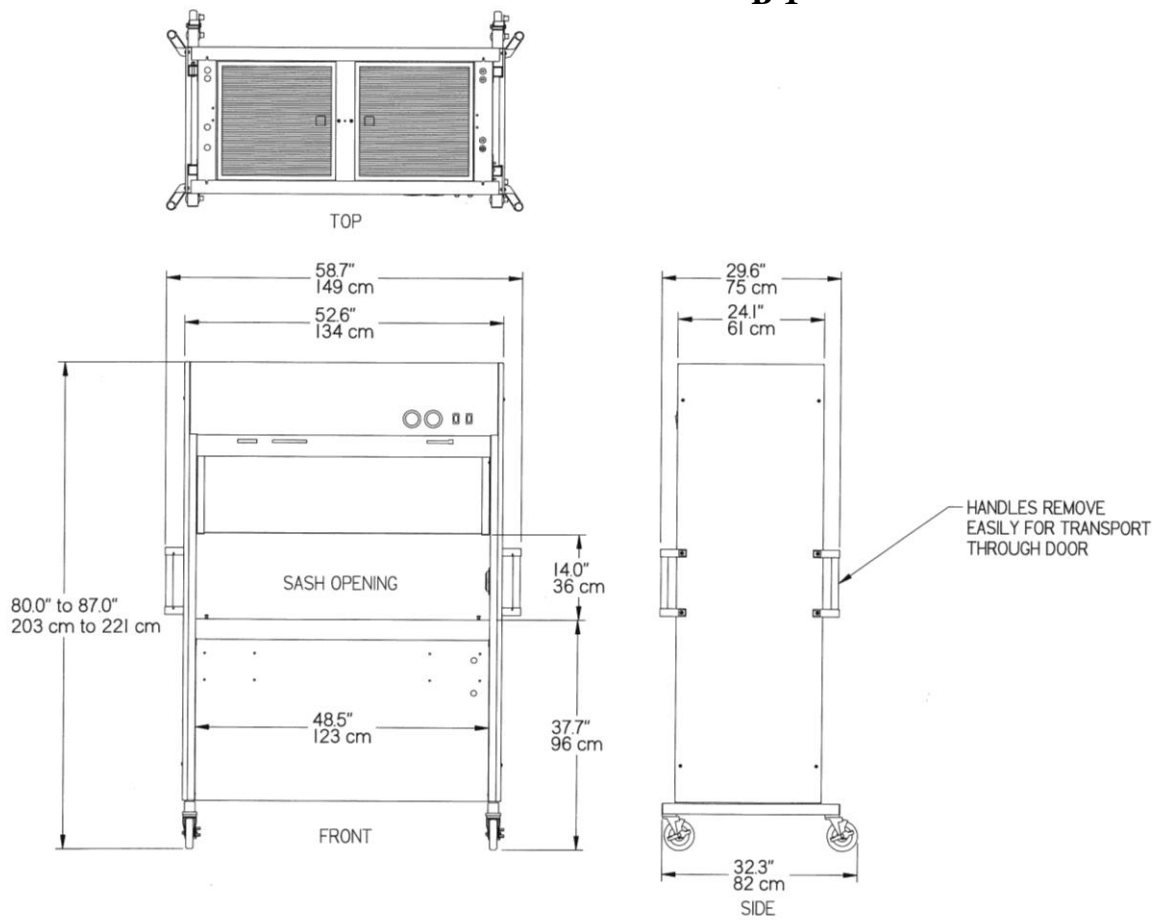

APPENDIX C

VERTICAL FLOW STATION

SPECIFICATIONS

Electrical Data

Station Model	Electrical Requirements
3830000 to -09	115 VAC – 60 Hz, 1 Phase – 12 Amps

Station Model	Electrical Requirements
3830020 to -29	230 VAC – 50/60 Hz, 1 Phase – 7 Amps

Impeller Specifications

Station Model	Electrical Requirements
3830000 to -09	115 Volt – 60 Hz, 100 Watt, 2550 RPM Automatic Thermal Protection

Station Model	Electrical Requirements
3830020 to -29	230 Volt – 50/60 Hz, 100 Watt, 2550 RPM Automatic Thermal Protection

Motor Specifications

Station Model	Electrical Requirements
3830000 to -09	115 VAC – 60 Hz, 3.8 Full Load Amps 1/3 H.P. 1625 RPM Automatic Thermal Protection

Station Model	Electrical Requirements
3830020 to -29	230 VAC – 50/60 Hz, 2.8 Full Load Amps 1/2 H.P. 1625 RPM Automatic Thermal Protection

Environmental Conditions

- Indoor use only.
- Maximum altitude: 6562 feet (2000 meters).
- Ambient temperature range: 41° to 104°F (5° to 40°C).
- Maximum relative humidity: 80% for temperatures up to 88°F (31°C), decreasing linearly to 50% relative humidity at 104°F (40°C).
- Main supply voltage fluctuations not to exceed $\pm 10\%$ of the nominal voltage.
- Transient overvoltages according to Installation Categories II (Overvoltage Categories per IEC 1010). Temporary voltage spikes on the AC input line that may be as high as 1500V for 115V models and 2500V for 230V models are allowed.
- Used in an environment of Pollution degrees 2 (i.e., where normally only non-conductive atmospheres are present). Occasionally, however, a temporary conductivity caused by condensation must be expected, in accordance with IEC 664.

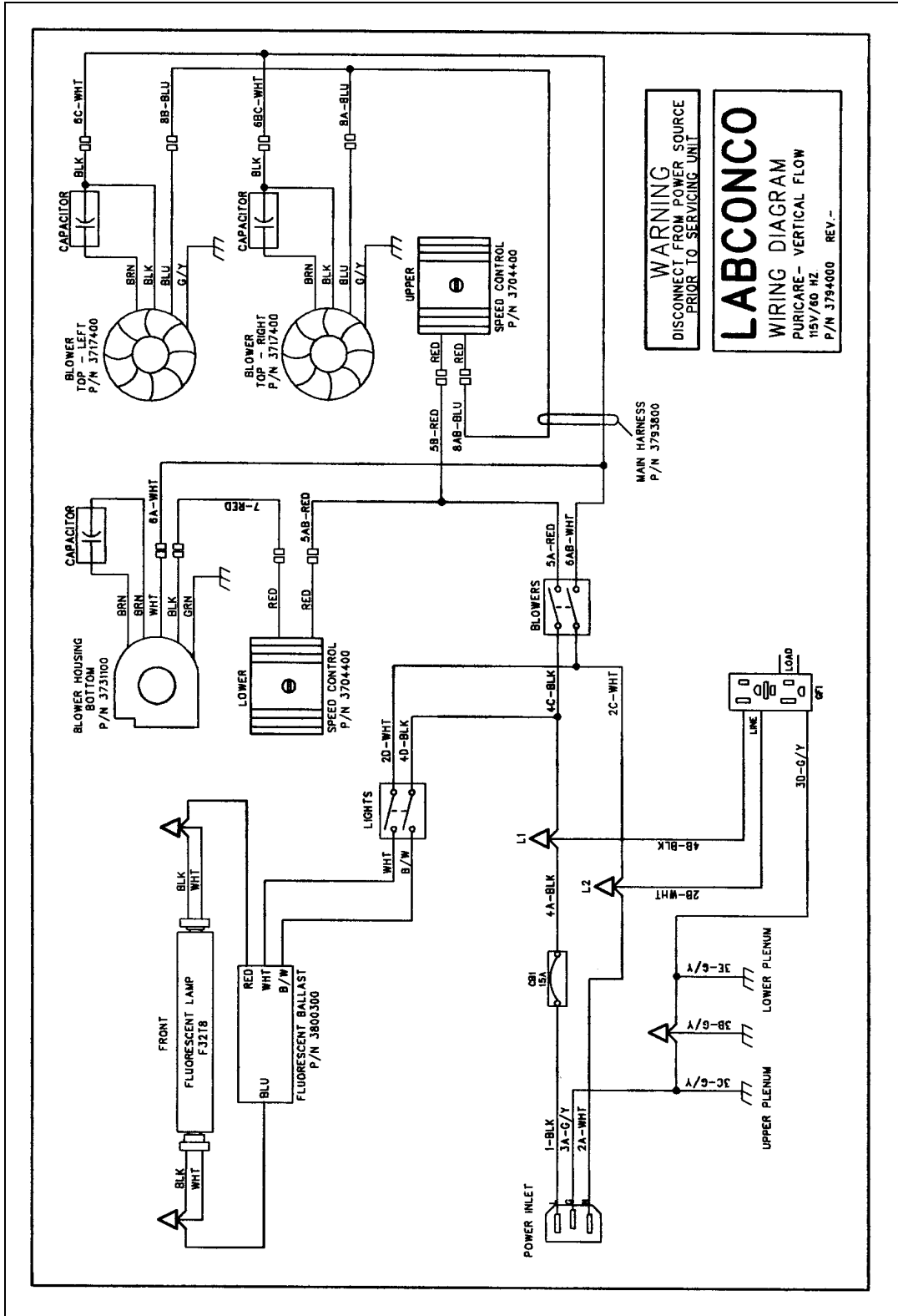

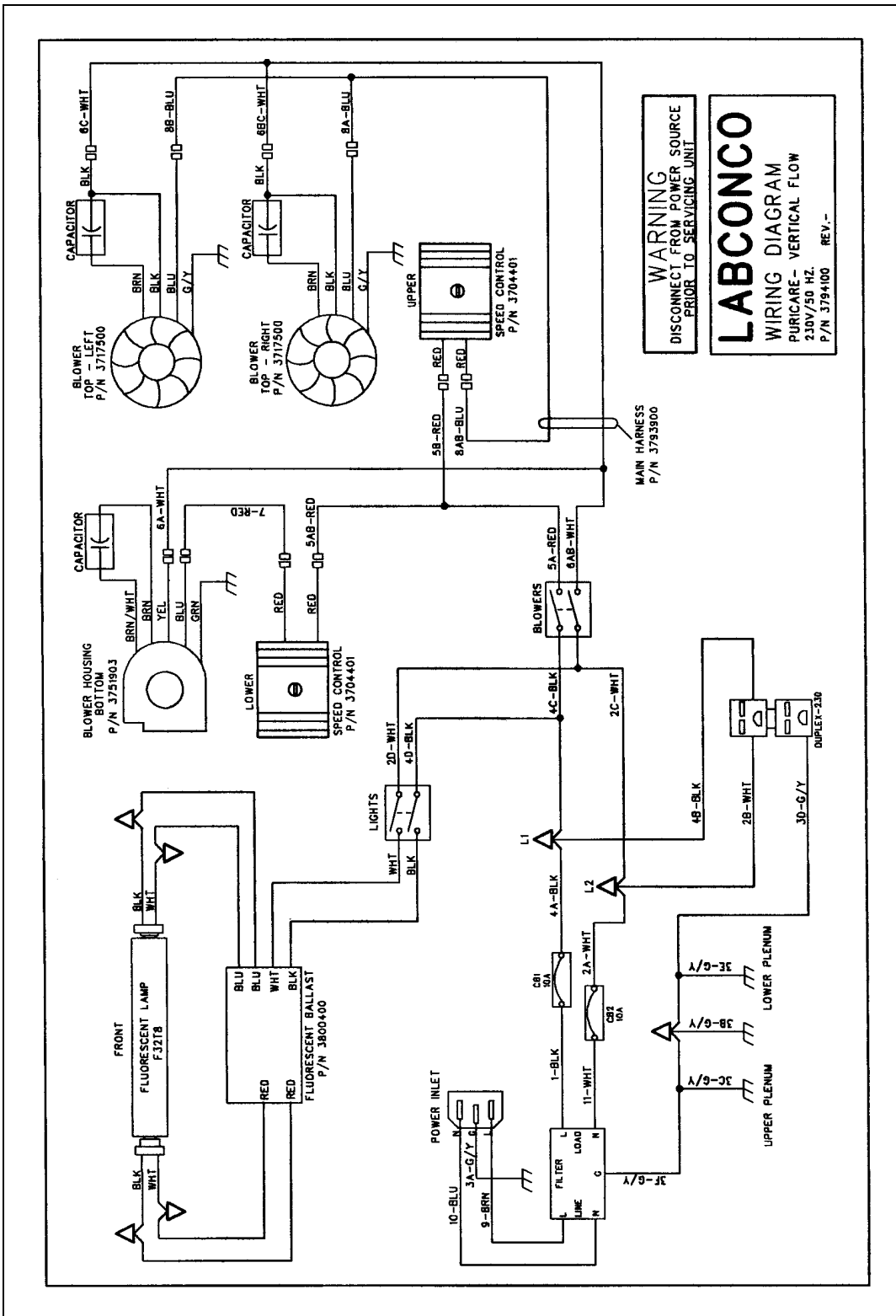

APPENDIX D

PURICARE ACCESSORIES

Shelf Kit

Shelf kits are available for either the left side (part number 3794900) or the right side (part number 3794901). The shelves are suitable for mounting on either side of the station. The shelves have a capacity of 20 pounds, a trigger to release the shelf, and fold down flat when not in use.

APPENDIX E

QUICK CHART FOR THE PURICARE VERTICAL FLOW STATONS

Model	38300
Sash Height (inches)	14
Downflow (FPM)	50-55
Approximate Settings for new Filters	
Mag Gauge Reading	0.3-0.4 upper / 0.5-0.7 lower
Supply Air Volume Displacement (CFM)	440
Number of Laskin Nozzles Needed	1
Exhaust Air Volume Displacement (CFM)	650-670
Number of Laskin Nozzles Needed	2
Supply HEPA Filter Dims. (in.)	48x18x3
Exhaust HEPA Filter Dims (in.)	48x18x6
Fluorescent Light(s)	1 each F32T8/TL741

*For further details on the secondary inflow method, consult the inflow velocity calculation – Secondary Method section of *Chapter 6: Maintaining Your PuriCare*.

Use the downflow velocity test grid as described in this manual when checking the downflow air velocity.

APPENDIX F

REFERENCES

Many excellent reference texts and booklets are currently available. The following is a brief listing:

Biosafety in Microbiological and Biomedical Laboratories. 4th Edition, May 1999. U.S. Department of Health, Education, and Welfare, National Institutes of Health, Division of Safety, Bethesda, MD 20892.

Laboratory Safety: Principles and Practices. 2nd Edition 1995. American Society for Microbiology, Washington, D.C.

The Foundations of Laboratory Safety. 1990. Stephen R. Rayburn. Springer-Verlag, New York.

Websites of Interest:

www.absa.org

www.cdc.gov

www.labconco.com