



Please read user's manual  
before operating equipment

Original Instructions

## LABCONCO CORPORATION

8811 Prospect Avenue  
Kansas City, MO 64132  
(800) 821-5525 | +1 (816) 333-8811  
[labconco.com](http://labconco.com)

# User's Manual

## Protector<sup>®</sup> Echo<sup>™</sup> & Protector<sup>®</sup> Airo<sup>™</sup> Filtered Fume Hoods



Register this product

**Protector<sup>®</sup> Echo<sup>™</sup> Bench Top Filtered Fume Hood**  
**2020—Present**

180410xxx	180510xxx	180610xxx	180810xxx
181410xxx	181510xxx	181610xxx	181810xxx
182410xxx	182510xxx	182610xxx	182810xxx

**Protector<sup>®</sup> Airo<sup>™</sup> Bench Top Filtered Fume Hood**  
**2020—Present**

184300xxx	184310xxx	184410xxx
-----------	-----------	-----------

**Protector<sup>®</sup> Echo<sup>™</sup> Floor Mount Filtered Fume Hood**  
**2020—Present**

183417xxx	183517xxx	183617xxx	183817xxx
183427xxx	183527xxx	183627xxx	183827xxx
183437xxx	183537xxx	183637xxx	183837xxx

Copyright © 2025 Labconco Corporation. The information contained in this manual and the accompanying products are copyrighted and all rights reserved by Labconco Corporation. Labconco Corporation reserves the right to make periodic design changes without obligation to notify any person or entity of such change.

## Warranty

Labconco Corporation provides a warranty to the original buyer for the repair or replacement of parts and reasonable labor as a result of normal and proper use of the equipment with compatible chemicals. Broken glassware and maintenance items, such as filters, gaskets, light bulbs, finishes and lubrication are not warranted. Excluded from warranty are products with improper installation, erratic electrical or utility supply, unauthorized repair and products used with incompatible chemicals.

The warranty for Protector® Echo™ & Protector® Airo™ Filtered Fume Hoods will expire one year from date of installation or two years from date of shipment from Labconco, whichever is sooner. Warranty is non-transferable and only applies to the owner (organization) of record.

Buyer is exclusively responsible for the set-up, installation, verification, decontamination or calibration of equipment. This limited warranty covers parts and labor, but not transportation and insurance charges. If the failure is determined to be covered under this warranty, the dealer or Labconco Corporation will authorize repair or replacement of all defective parts to restore the unit to operation. Repairs may be completed by 3<sup>rd</sup> party service agents approved by Labconco Corporation. Labconco Corporation reserves the rights to limit this warranty based on a service agent's travel, working hours, the site's entry restrictions and unobstructed access to serviceable components of the product.

Under no circumstances shall Labconco Corporation be liable for indirect, consequential, or special damages of any kind. This warranty is exclusive and in lieu of all other warranties whether oral, or implied.

## Returned or Damaged Goods

Do not return goods without the prior authorization from Labconco. Unauthorized returns will not be accepted. If your shipment was damaged in transit, you must file a claim directly with the freight carrier. Labconco Corporation and its dealers are not responsible for shipping damages.

The United States Interstate Commerce Commission rules require that claims be filed with the delivery carrier within **fifteen (15) days** of delivery.

## Limitation of Liability

The disposal and/or emission of substances used in connection with this equipment may be governed by various federal, state, or local regulations. All users of this equipment are required to become familiar with any regulations that apply in the user's area concerning the dumping of waste materials in or upon water, land, or air and to comply with such regulations. Labconco Corporation is held harmless with respect to user's compliance with such regulations.

### **For additional questions or support:**

**Labconco Customer Care** +1 (816) 333-8811

**Labconco Technical Support** (800) 821-5525

**Hours** 7:30 a.m.-5:30 p.m. CST

# Table of Contents

---

<b>1: INTRODUCTION</b>	<b>9</b>
About This Manual	9
Contents Included	9
<b>2: BEFORE YOU INSTALL</b>	<b>10</b>
Location Requirements	10
Clearance Requirements	10
Electrical Requirements	11
Service Line Requirements	11
<b>3: SAFETY PRECAUTIONS</b>	<b>12</b>
Typographical Conventions	12
General Safety Precautions	14
Safety Precautions for this Product	15
<b>4: INSTALLATION</b>	<b>22</b>
Unpacking	22
Installation	24
Filter Installation	28
Calibrating the Airflow Sensor	32
Certification	34
Re-Certification	34
<b>5: PERFORMANCE FEATURES</b>	<b>35</b>
Directional Airflow	35
HEPA Filters	35

Neutrodine® Filters	36
Fan/Motor	36
Front Airfoil	36
Work Area	37
Internal Service Lines	37
Anemometer (Airflow Sensor)	37

## **6: FILTERED HOOD OPERATING SYSTEM 38**

Command Module	38
Connecting to your filtered hood	39
eGuard	40
Alarm Screens	40

## **7: USING YOUR FILTERED HOOD 42**

<b>System Reset</b>	<b>42</b>
Reset with eGuard	42
Manual Reset Switch	42
<b>Sash Operation</b>	<b>43</b>
<b>Controls</b>	<b>43</b>
Fans	43
Lighting	43
Airflow Sensor	43
Mute Alarm	43
Outlet (Optional)	44
<b>Start-up</b>	<b>44</b>
<b>Loading Product / Materials</b>	<b>44</b>
<b>Work Techniques</b>	<b>44</b>
<b>Unloading Product / Materials</b>	<b>44</b>
<b>Shutdown</b>	<b>45</b>

## **8: MAINTAINING YOUR FILTERED HOOD 46**

<b>Maintenance Safety Precautions</b>	<b>46</b>
<b>Recommended Maintenance Schedule</b>	<b>47</b>
<b>Service Operations</b>	<b>47</b>
Front Panel Removal	48
Pre-filter Replacement	49
Base Frame Replacement	51
Neutrodine Filter Replacement	55
Fan Replacement	59
Optional HEPA Filter Installation or Replacement	61
Airflow Sensor Replacement	65
Solvent, Acid & Formaldehyde Sensor Replacement	66

## **9: ACCESSORIES** **69**

<b>Filters</b>	<b>69</b>
<b>Work Surfaces</b>	<b>69</b>
<b>Base Stands, Accessory Shelves, Seismic Supports, and Hydraulic Lift Base Stands</b>	<b>71</b>
<b>Storage Cabinets</b>	<b>72</b>
<b>Installing Additional Service Fixtures</b>	<b>72</b>
Standard Service Fixture Kits	72
Cold Water Gooseneck Fixture Kits	73
Hot and Cold Water Mixing Gooseneck Fixture Kit	73
Deionized/Distilled Water Gooseneck Fixture Kit	74
<b>Installing an Electrical Duplex Outlet</b>	<b>74</b>
Electrical Receptacle Kits	74
<b>Sash Stop Kit</b>	<b>75</b>
<b>Distillation Grid Kits</b>	<b>75</b>
<b>Sash Reduction Wing Kits</b>	<b>75</b>

## **10: TROUBLESHOOTING** **77**

<b>Service valves no longer operate</b>	<b>77</b>
<b>Fans and Lights not working</b>	<b>78</b>
<b>Vertical sash no longer operates smoothly</b>	<b>79</b>
<b>Electrical duplex outlets no longer have power</b>	<b>80</b>

Fan operates but lights dim or not working	80
Contaminates outside the filtered hood	81
Lights operate but fans will not	82
Smart Command Alarms	83
<b>APPENDIX A: PARTS LIST</b>	<b>85</b>
Neutrodine (by Erlab) Filtration Technology Replacement Parts	86
<b>APPENDIX B: DIMENSIONS</b>	<b>89</b>
Protector® Echo™ Bench Top Filtered Fume Hood	89
Protector® Echo™ Floor Mount Filtered Fume Hood	90
Protector® Airo™ Bench Top Filtered Fume Hood	91
<b>APPENDIX C: SPECIFICATIONS</b>	<b>93</b>
Environmental Conditions	93
Wiring Diagram	94
<b>APPENDIX D: EGUARD</b>	<b>95</b>
Command Module	95
<i>Index:</i> Connecting to your filtered hood with eGuard	95
INFO	96
LOGS	97
SETTINGS	97
<i>Update:</i> Connecting to your filtered hood with eGuard	100
INFO	100
eGuard Access Summary	102
<b>APPENDIX E: SETTING UP THE PROTECTOR ECHO FLOOR-MOUNTED FILTERED HOOD</b>	<b>103</b>
Unpacking	104

<b>Remove from Shipping Skid</b>	<b>104</b>
<b>Lower Base Installation</b>	<b>104</b>
<b>Upper Cabinet Installation</b>	<b>105</b>
<b>Sash Installation</b>	<b>105</b>
Vertical Sashes	105
Sash Weights	106
Sash Stops	106
<b>Corner Post Installation</b>	<b>106</b>
<b>Wiring</b>	<b>107</b>
<b>Baffle Installation</b>	<b>108</b>
<b>Header Installation</b>	<b>108</b>
<b>Filter Installation</b>	<b>108</b>
<b>Front Panel Installation</b>	<b>108</b>
<b>APPENDIX F: APPROVED CHEMICALS</b>	<b>110</b>
<b>The Short List of Chemicals Not Recommended</b>	<b>110</b>
<b>APPENDIX G: ACID/FORMALDEHYDE SENSOR LOCATIONS</b>	<b>112</b>
<b>APPENDIX H: LOW CLEARANCE AFS REPLACEMENT</b>	<b>113</b>

# 1: Introduction

---

Congratulations on the purchase of a Labconco Protector® Echo™ or Protector® Airo™ Filtered Fume Hood. The filtered hood is designed on a traditional fume hood platform along with Neutrodine® Filters that handle solvents, acids, and bases with one comprehensive filter. It is the result of years of experience in manufacturing laboratory equipment, and users like you suggested many of its features to us.

This filtered hood offers many unique features. To take full advantage of them, please acquaint yourself with this manual and keep it handy for future reference.

## About This Manual

This manual is written for the installer and user of this product.



This manual contains important operation and safety information. When you see a symbol, such as the INFO symbol to the left, pay close attention to the information provided. Before installing or operating this product, you must read [Section 3: Safety Precautions](#).

## Contents Included

The following items are packaged with the product.

- User's manual thumb drive
- Air and vacuum fixture knobs, labels and hose connectors
- Power cord and power supplies
- Quick Start Guide
- Fan boxes

The location of these items and additional details are found in [Section 4: Installation](#).

## 2: Before You Install

---

Before you install the product, the site should be planned for installation. Examine the location where you intend to install it. You must be certain that the area is level and of solid construction. In addition, a dedicated source of electrical power must be located near the installation site.

Carefully read this chapter to learn the requirements for the installation site:

- The location requirements.
- The support requirements.
- The electrical power requirements.
- The service line requirements.
- The space requirements.

### Location Requirements

The filtered hood should be located away from traffic patterns, doors, windows, fans, ventilation registers, and any other air-handling device that could disrupt its airflow patterns. All windows in the room should be closed.

La hotte filtrée devrait être situé loin des modèles de trafic, portes, fenêtres, ventilateurs, registres de ventilation, et tout autre dispositif de traitement de l'air qui pourraient perturber ses modèles de flux d'air. Toutes les fenêtres de la chambre doivent être fermés.

### Clearance Requirements

See [Appendix B: Dimensions](#) for overall product dimensions for space requirements of the installation site.

## Electrical Requirements

The product models have the following electrical requirements.

**Table 2-1**

Hood Width	Airflow (CFM)	Makeup Air (CFM)	Face Velocity (fpm)	No. of Modules	Fan Power (watts)	Light Power (watts)	Total Power (watts)
3 FT	Up to 130	0, limited to min. volume required by local regulations and min. laboratory air change requirements	60-100	1	36	18	54
4 FT	Up to 260		60-100	2	72	36	108
5 FT	Up to 390		60-100	3	108	54	162
6 FT	Up to 520		60-100	4	144	72	216
8 FT	Up to 650		60-100	5	180	90	270

**A dedicated outlet with an appropriate circuit breaker should be located as close as possible to the product. Consult your local electrical codes for properly rated circuit breakers. For safe operation the dedicated outlet must provide a protective earthing ground connection to the product.**

## Service Line Requirements

All service lines to the filtered hood should be ¼-inch outside diameter, copper (brass for natural gas), and equipped with an easily accessible shut-off valve, should disconnection be required. Recommended operating pressure is 40 PSI, with a maximum allowable pressure of 200 PSI. Consider a pressure regulator to reduce line pressure to 40 PSI. Please check with local codes for other requirements.

## 3: Safety Precautions

---

Before unpacking, installing, operating, maintaining, or servicing this equipment, read the following safety warnings and precautions.

Avant le déballage, l'installation, le fonctionnement, l'entretien ou la maintenance de cet équipement, lire les avertissements de sécurité et les précautions d'emploi.



**CAUTION** – See Manual. When this symbol is on the equipment, it indicates a caution that is detailed in this manual.

**MISE EN GARDE** – Voir le manuel. Lorsque ce symbole est apposé sur l'équipement, il renvoie à une mise en garde détaillée dans ce manuel.

### Typographical Conventions



**DANGER** – An imminently hazardous situation which, if not avoided, will result in death or serious injury.

**DANGER** – Situation dangereuse imminente qui, si elle n'est pas évitée, peut entraîner la mort ou des blessures graves.



**CAUTION** – Indicates a potentially hazardous situation which, if not avoided, may result in minor or moderate injury or damage to property.

**MISE EN GARDE** – Signale une situation potentiellement dangereuse qui, si elle n'est pas évitée, peut provoquer des blessures mineures à modérées ou des dommages matériels.



**NOTE** – Advice or suggestions to help the process.

**REMARQUE** – Conseils ou suggestions pour le déroulement du processus.



**BURN RISK (HIGH TEMPERATURE)** – Air or components that will be very hot. Take care not to touch these defined areas. Failure to avoid these areas may result in moderate to severe injury.

**RISQUE DE BRÛLURE (TEMPÉRATURE ÉLEVÉE)** – Air ambiant ou composant devenant très chaud. Veiller à ne pas toucher ces zones délimitées. L'absence de précaution pour éviter ces zones peut entraîner des blessures modérées, voire graves.



**EXTREME COLD (LOW TEMPERATURE)** – Air or components that will be very COLD. Take care not to touch these defined areas. Failure to avoid these areas may result in moderate to severe injury.

**FROID INTENSE (TEMPÉRATURE BASSE)** – Air ambiant ou composant devenant très froid. Veiller à ne pas toucher ces zones délimitées. L'absence de précaution pour éviter ces zones peut entraîner des blessures modérées voire graves.



**PINCH POINT** – Areas or components that can pinch or cut. Take care not to touch these defined areas.

**POINT DE PINCEMENT** – Zones ou composants présentant un risque de pincement ou de coupure. Veiller à ne pas toucher ces zones délimitées.



**MOVING PARTS** – Areas or components that contain moving parts. Take care not to touch these defined areas.

**PIÈCES MOBILES** – Zones ou composants contenant des pièces mobiles. Veiller à ne pas toucher ces zones délimitées.



**RISK OF ELECTRICAL SHOCK** – The specified procedure or area poses a risk of electrical shock. ALWAYS disconnect main power cord or electrical supply before proceeding.

**RISQUE DE CHOC ÉLECTRIQUE** – La procédure ou la zone spécifiée présente un risque de choc électrique. TOUJOURS débrancher le cordon d'alimentation secteur ou l'alimentation électrique avant toute intervention.



**FLAMMABLE / NO SOLVENTS** – Do not place flammable liquids or solvents in this product.

**INFLAMMABLE / PAS DE SOLVANTS** – Ne placez aucun liquid inflammable dans cette produit.



**LIFTING HAZARD** – Do not lift or move this equipment without assistance.

**DANGER DE LEVAGE** – Ne pas soulever ou déplacer cet équipement sans assistance.



**MAGNETIC FIELD IN USE** – Magnets or magnetic field present.  
**CHAMP MAGNETIQUE UTILISE** – Présence d'aimants ou de champ magnétique.



**DO NOT TOUCH** – Components or areas indicated are sensitive and will suffer damage if touched. Take care not to touch these defined components or areas. Failure to avoid these areas will result in damage to the product.

**NE PAS TOUCHER** – Les composants ou les zones indiquées sont sensibles et subiront des dégâts s'ils sont touchés. Veiller à ne pas toucher ces composants ou zones délimité(e)s. L'absence de précaution pour éviter ces zones endommagera le produit.



**TOOL REQUIRED** – Tool required to access specified area.  
**OUTIL NÉCESSAIRE** – Outil nécessaire pour accéder à la zone spécifiée.

## General Safety Precautions

Follow all the safety precautions described in this section.



Before removing any panels which require a tool for removal, ALWAYS disconnect the main power cord or electrical supply. Failure to remove all electrical power before proceeding will result in moderate to serious injury, death, or damage to property.

Avant le retrait d'un panneau nécessitant l'utilisation d'un outil, TOUJOURS débrancher le cordon d'alimentation secteur ou l'alimentation électrique. Le non-respect de la consigne consistant à couper complètement l'alimentation électrique avant toute intervention peut entraîner des blessures graves, la mort ou des dommages matériels.



Never contact moving parts with your person. Failure to avoid moving parts will result in moderate to serious injury, death, or damage to property.

Ne jamais toucher les parties mobiles. Le non-respect de la consigne consistant à éviter les pièces mobiles peut entraîner des blessures graves, la mort ou des dommages matériels.



Never misuse this product. Never disable, override, or otherwise bypass safety guards, panels, switches, sensors or alarms. Doing so will result in moderate to serious injury, death, or damage to this product or property.

Ne jamais utiliser ce produit à mauvais escient. Ne jamais désactiver, annuler ou contourner les capots, panneaux, interrupteurs, capteurs ou alarmes de sécurité. Ceci entraînerait des blessures graves, la mort ou des dommages matériels à ce produit ou à d'autres biens.



If the unit is not operated as specified in this manual it may impair the protection provided by the unit.

Si l'unité n'est pas utilisée comme spécifié dans ce manuel il peut diminuer la protection fournie par l'unité.



Do not position the unit so that it is difficult to operate the main disconnect device.

Ne placez pas l'appareil de sorte qu'il est difficile de faire fonctionner le dispositif principal de déconnexion.



Do not lift or move this equipment without assistance.

Ne pas soulever ou déplacer cet équipement sans assistance.

## Safety Precautions for this Product



Only use the materials that were approved from the LP report as filed before purchasing this filtered hood.

N'utilisez que les matériaux approuvés par la LP rapport tels que déposés avant d'acheter cette hotte filtrante.



Although the filtered hood has been engineered to maintain optimum operator safety, caution should always be used while working in the hood. Prior to using the hood, check to make sure that the exhaust blower is operating, the command module is illuminated and that air is entering the hood at its specified face velocity.

Bien que la hotte filtrante ait été conçue pour maintenir une sécurité optimale de l'opérateur, il faut toujours être prudent lorsque vous travaillez dans la hotte.

Avant d'utiliser la hotte, assurez-vous que le ventilateur d'évacuation fonctionne, que le module de commande est allumé et que l'air pénètre dans la hotte à la vitesse nominale spécifiée.



Use good housekeeping in the hood at all times. Clean up spills immediately with a mild detergent. Periodically clean hood interior. Replace burned out LED lights to maintain maximum illumination.



Do not overload the work surface with apparatus or work material. The safe operation of the laboratory hood is based upon having proper airflow through the structure. Do not place large, bulky objects such as block heaters, directly on the hood work surface. Instead, elevate the object 1 to 2 inches on blocks to allow a flow of air under the object and into the lower rear baffle exhaust slot. Ensure blocks are level and secured in place.



Avoid placing your head inside hood. Keep hands out of hood as much as possible.

Eviter de placer votre tête à l'intérieur de la hotte. Garder les mains à l'extérieur de la hotte le plus possible.



Always work as far back in hood as possible. It is best to keep all chemicals and apparatus 6" inside the front of the hood.

Toujours travailler aussi loin que possible de la hotte. Il est recommandé de garder tous les produits chimiques et appareils à 6 pouces à l'intérieur de l'avant de la hotte.



This hood does not feature explosion-proof electrical components. Therefore, use of flammable or explosive materials in quantities above the explosive limit are not recommended.

Cette hotte ne possède pas de composants électriques anti-explosion. Donc, l'usage de matériels inflammables ou explosifs dans les quantités au-dessus de la limite explosive n'est pas recommandé.



Do not work with chemicals in this hood without the fan system running, the command module illuminated and a face velocity of 60-100 fpm. Do not store chemicals in a filtered hood.

Ne travaillez pas avec des produits chimiques dans cette hotte sans que le système de ventilation ne fonctionne, le module de commande illuminé et une vitesse frontale de 60 à 100 pi / min. Ne stockez pas de produits chimiques dans une hotte filtrante.



The use of safety goggles, protective clothing, gloves, and other personal protective equipment recommended by your safety officer should be used.

L'utilisation de lunettes de sécurité, des vêtements de protection, des gants et autres équipements de protection personnelle recommandés par votre agent de sécurité doit être utilisé.



Perchloric acid use in this hood is prohibited.

L'usage d'acide perchlorique sous cette hotte est interdit.



High level radioisotope materials are prohibited for usage in this hood.

Les matériels d'isotope radioactif de haut niveau sont interdits à l'usage sous cette hotte.



Do not use with organophosphoric (insecticide) compounds, mercury, hydrogen cyanide, or highly exothermic reactions. High exothermic reactions and smoke generation require the use of a HEPA filter.

Ne pas utiliser avec (insecticides) composés organophosphorés, le mercure, le cyanure d'hydrogène, ou des réactions fortement exothermiques. Réactions exothermiques élevées et la production de fumée nécessitent l'utilisation d'un filtre HEPA.



The following compounds are not retained well: Helium and the Noble Gases, Hydrogen, Ethane, Ethylene Oxide, Methane, Carbon Monoxide, Carbon Dioxide, Nitrogen Monoxide, Propylene, Propyne, Propane, and Acetylene.

Les composés suivants ne sont pas bien conservés: l'hélium et les gaz nobles, hydrogène, d'éthane, l'oxyde d'éthylène, méthane, monoxyde de carbone, dioxyde de carbone, d'azote monoxyde, propylène, Propyne, propane et d'acétylène.



Avoid cross drafts and limit traffic in front of the hood. Air disturbances created may draw fumes out of the hood.



The use of heat-generating equipment in this hood without the fan system operating properly can cause damage to the hood. The filtered hood exemplifies robust heat tolerance from hot plates, ovens, or other heat-generating equipment up to 1058 watts or 300-degrees C surface temperature. If heat exceeds 1058 watts or 300-degrees C surface temperature, then the application requires a ducted hood rather than a filtered hood. The filtered hood should not be used when the internal temperature rises greater than 5-degrees C above ambient room temperature. See [Appendix D: eGuard - Settings, Other Sensors](#), to change the temperature trigger value.

L'utilisation d'équipements générant de la chaleur dans cette hotte sans le système de ventilateur fonctionnant correctement peut provoquer des dommages à la hotte. La hotte filtrée illustre la tolérance à la chaleur robuste des plaques chauffantes, des fours ou d'autres équipements générant de la chaleur jusqu'à 1058 watts ou une température de surface de 300 degrés C. Si la chaleur dépasse 1058 watts ou une température de surface de 300 degrés C, l'application nécessite une hotte canalisée plutôt qu'une hotte filtrée. La hotte filtrante ne doit pas être utilisée lorsque la température interne s'élève de plus de 5 degrés C au-dessus de la température ambiante. Voir Annexe D: eGuard - Paramètres, Autres capteurs, pour modifier la valeur de déclenchement de la température.



The filtered hood should be certified by a qualified certification technician before it is initially used. The filtered hood should be re-certified whenever it is relocated, serviced or at least annually thereafter. Certification requirements to come from Chemical Hygiene Officer.

Le Protecteur filtrée capot doit être certifié par un technicien qualifié avant de certification, il est d'abord utilisé. Le capot filtrée devrait être re-certifié à chaque fois qu'il est déplacé, la réparation ou au moins annuellement par la suite. Les exigences de certification doivent provenir d'un agent d'hygiène chimique.



Ensure that the hood is connected to electrical service in accordance with local and national electrical codes. Failure to do so may create a fire or electrical hazard. Do not remove or service any electrical components without first disconnecting the hood from electrical service.

Assurez-vous que le capot est connecté au service électrique conformément aux codes électriques locaux et nationaux. Ne pas le faire peut créer un risque d'incendie ou électrique. Ne pas enlever ou de réparer des composants électriques sans d'abord débrancher la hotte du service électrique.



Proper operation of the filtered hood depends largely upon the hood's location and the operator's work habits.

Le bon fonctionnement de la hotte filtrée dépend largement de l'emplacement de la hotte et les habitudes de travail de l'opérateur.



If the hood is not operated as specified in this manual, it may impair the protection it provides.

Si la hotte ne est pas utilisé comme spécifié dans ce manuel, il peut porter atteinte à la protection qu'il offre.



Do not touch the fan motors. The surfaces of the motor can become hot, cause burns or cause damage.

Ne touchez pas les moteurs de ventilateur. Les surfaces du moteur peuvent devenir chauds, causer des brûlures ou causer des dommages.



Do not position the filtered hood so that it is difficult to operate the main disconnect device.

Ne pas positionner la hotte filtrée de sorte qu'il est difficile de faire fonctionner le dispositif de déconnexion principal.



To prevent the possibility of minor injury keep hands and fingers clear of pulleys or sprockets at the top of the four corners.

Pour éviter la possibilité de blessure mineure garder les mains et les doigts de poulies ou pignons au sommet des quatre coins.



Use of an open flame must be avoided. Open flames may disrupt the airflow patterns in the cabinet and cause a fire hazard with volatile chemicals and solvents.

Utilisation d'une flamme doit être évitée. Flammes nues peuvent perturber les modèles de flux d'air dans le boîtier et provoquer un risque d'incendie avec des produits chimiques et des solvants volatils.



Handle new and used filters with care during installation and removal. Refer to instructions in this manual for proper handling of filters.

Poignée de nouveaux filtres et utilisés avec précaution lors de l'installation et l'enlèvement. Consulter les instructions dans ce manuel pour la manipulation correcte des filtres.



Saturated carbon filters and HEPA filters are to be disposed of as hazardous waste. The user is responsible for recording the chemicals adsorbed or removed by the filters and disposing of them properly.

Filtres de carbone saturés et les filtres HEPA doivent être éliminés comme des déchets dangereux. L'utilisateur est responsable de l'enregistrement des produits chimiques adsorbé ou enlevés par les filtres et de les jeter correctement.



Use in areas where only trained users have access to the filtered hood. Any new users must be trained and should also read this User's Manual.

Utilisez dans les zones où seuls les utilisateurs formés ont accès à la hotte filtré. Les nouveaux utilisateurs doivent être formés et doivent également lire le manuel de l'utilisateur.



Do not use the filtered hood in a poorly ventilated area. If the hood is to be used in a confined space, make sure the space is well ventilated and the concentration of toxic contaminants cannot accumulate greater than the exposure limit/TWA.

Ne pas utiliser la hotte filtré dans un endroit mal ventilé. Si la hotte doit être utilisé dans un espace confiné, assurez-vous que l'espace est bien ventilé et la concentration des contaminants toxiques ne peut accumuler plus grande que la limite d'exposition / TWA.



The warning properties (i.e., odor, taste) of the volatile organic compounds or other material being used in the filtered hood must be adequate to provide an early indication that the carbon filter may be saturated. In other words, it is best when the odor threshold is less than the exposure limit/TWA.

Les propriétés d'alerte (par exemple, l'odeur, goût) de la ou des composés organiques volatils autres matériaux utilisés dans l'enceinte doit être suffisante pour fournir une première indication que le filtre à charbon peut être saturé. En d'autres termes, il est préférable lorsque le seuil d'odeur est inférieure à la limite d'exposition / TWA.



Highly toxic vapors, unknown reactions, hazardous particulates, or processes generating high levels of contaminants are not intended for use in the filtered hood.

Vapeurs très toxiques, réactions inconnus, des particules dangereuses, ou de procédés produisant des niveaux élevés de contaminants ne sont pas destinés à être utilisés dans la hotte filtrée.



Only chemicals which can be safely adsorbed/treated with the specific carbon-based filters installed or removed by HEPA filters are appropriate for use in this filtered hood. Reference the approved LP report.

Seuls les produits chimiques qui peuvent être adsorbés / traités en toute sécurité avec les filtres à base de carbone spécifiques installés ou retirés par les filtres HEPA sont appropriés pour une utilisation dans cette hotte filtrée. Référez le rapport LP approuvé.



Use the smallest possible quantity of chemical(s) within the filtered hood and never exceed the amount which can be effectively adsorbed by the filters before breakthrough.

Utilisez la plus petite quantité possible de produit chimique (s) dans le capot filtrée et ne jamais dépasser le montant qui peut être efficacement adsorbé par les filtres avant de percée.



Leave the fans on for at least one minute after work in the filtered hood has been completed.

Laissez le ventilateur pendant au moins une minute après le travail dans la hotte filtrée a été achevée.



If a chemical is spilled on the work surface DO NOT switch off the fans until all traces of the chemical has been removed.

Si un produit chimique est renversé sur la surface de travail Ne éteignez pas les fans jusqu'à ce que toutes traces de la substance chimique a été supprimé.



Make sure filters are installed prior to each use. Remove the front panel to install the filters.

Assurez-vous que les filtres sont installés avant chaque utilisation. Retirez le panneau avant pour installer les filtres.



If the fan fails during use, chemical processes should cease and the area should be vacated and ventilated before servicing the fans.

Si le ventilateur échoue lors de l'utilisation, les processus chimiques doivent cesser et la zone doit être libéré et ventilé avant de réparer le ventilateur.



Always refer to the [NIOSH Pocket Guide to Chemical Hazards](#) before proceeding. For additional help with filter and chemical selection, contact Labconco at 800-821-5525 or 816-333-8811.

Toujours se référer à l'NIOSH Pocket Guide to dangers des produits chimiques avant de procéder. Pour une aide supplémentaire avec filtre et de sélection chimique, contacter au 800-821-5525 ou Labconco 816-333-8811.



The surface of the optional HEPA filter is fragile and should not be touched. Care must be taken to avoid puncturing the HEPA filter during installation or normal operation. If you suspect that a HEPA filter has been damaged DO NOT use the filtered hood; contact a local certification agency or Labconco.

La surface du filtre HEPA est fragile et ne doit pas être touché. Des précautions doivent être prises pour éviter de perforer le filtre HEPA pendant l'installation ou le fonctionnement normal. Si vous soupçonnez qu'un filtre HEPA a été endommagé NE PAS utiliser le capot filtré; communiquer avec un organisme de certification local ou Labconco.



The optional HEPA filter in the filtered hood will gradually accumulate airborne particulate matter from the room and from work performed in the filtered hood. The rate of accumulation will depend upon the cleanliness of the room air, the amount of time the filtered hood is operating and the nature of work being done in the filtered hood.

Le filtre HEPA dans la hotte filtrée accumulera progressivement particules aéroportées de la salle et des travaux exécutés dans l'enceinte. Le taux d'accumulation dépend de la propreté de l'air ambiant, la quantité de temps le capot filtrée est en marche et la nature des travaux effectués dans la hotte filtré.



Tag the filtered hood with appropriate warning if any filters have been removed for service.

Marquer le capot filtrée avec avertissement approprié si des filtres ont été retirés du service.

## 4: Installation

---

With the installation site properly prepared, you are ready to unpack and install the equipment. This section covers how to:

- Unpack and move the equipment
- Install the equipment
- Connect electrical service
- Connect service utilities
- Seal the filtered hood to the work surface
- Install the filtration technology
- Connect to power
- Calibrate the filtered hood

### Unpacking



The following tools are required to unpack the equipment:

- Box Knife
- #2 Phillips Screwdriver or #2 Philips Bit Drill
- 7/16" Socket & Drill or 7/16" Wrench
- Pliers



The following safety precautions must be followed by all personnel unpacking the equipment.

- Wear safety glasses
- Wear gloves
- No loose fitting clothes
- Wear close-toed shoes
- Follow safe-lifting practices (do NOT attempt to lift this product without specialized lifting equipment certified to lift up to 1000 lbs.)

## Step 1

Carefully remove the shrink-wrap or outer carton and inspect the product for damage that may have occurred in transit. **All the filtration fans are packaged in boxes, secured to the top of the filtered hood with bubble wrap and should not be discarded.** If the product is damaged, take pictures of the product and the outer packaging, and notify the delivery carrier immediately. Retain the entire shipment, including outer packaging, intact for inspection by the carrier.



**Note:** United States Interstate Commerce Commission rules require that claims be filed with the delivery carrier within fifteen (15) days of delivery.

Do not return goods without the prior authorization of Labconco. Unauthorized returns will not be accepted.

If the product was damaged in transit, you must file a claim directly with the freight carrier. Labconco Corporation and its dealers are not responsible for shipping damages.

Do not discard the carton or packing material for the product until all of the components have been checked, installed and tested.

## Step 2



**Note:** Leave the filtered hood attached to its shipping skid until it is as close to its final location as possible. Move the filtered hood using a suitable floor jack, or by placing a furniture dolly underneath the skid. Do not move the filtered hood by tilting it onto a hand truck.

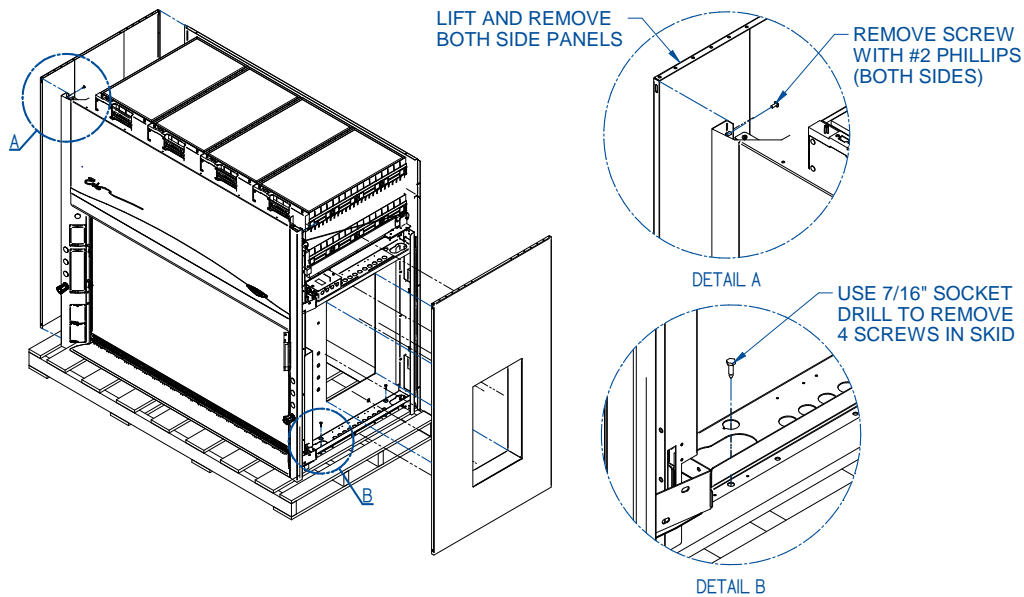

After you verify the filtered hood components, move the filtered hood to the location where you want to install it. Should you require disassembly to move the filtered hood, follow the instructions in [Appendix E: Setting up the Protector Echo Floor-mounted Filtered Hood](#). Then, follow the steps listed (and Figure 4-1) to remove the shipping skid from the unit.

1. Remove the Phillips screw per panel.
2. Lift each side panel up and away.
3. Locate the hardware (screws, washers, nuts) that attach the filtered hood to the skid and remove the hardware.

### Step 3

To protect the filtered hood from damage in shipment, the sash weight has been secured to the back of the filtered hood with screws. Simply remove the screws and make sure the sash cables or chains are on the pulleys or sprockets before operating the sash.



**Note:** The sash weight itself was individually matched for this specific filtered hood and should not be exchanged on any other unit.

### Installation

With the unpacked filtered hood properly prepared, you are ready for installation. This section covers how to:

- Install the filtered hood onto the work surface or benchtop
- Connect electrical service
- Connect service lines
- Seal the filtered hood to the work surface



The Protector Hood is heavy! Use caution when lifting or moving the unit.  
Le Protecteur Hood est lourd! Soyez prudent lorsque vous soulever ou déplacer l'appareil.

### Step 1

When installing the filtered hood onto a chemically-resistant work surface or benchtop, ensure that the structure can safely support the combined weight of the filtered hood and any related equipment. The work surface should be at least as wide as the filtered hood to properly support it. **The work surface is aligned flush with the back of the filtered hood: this will provide the correct spacing under the air foil for proper bypass airflow. The lower base cabinets are placed flush with the front of the work surface as shown in Figure 4-2.**

The work surface should be smooth and durable, such as a chemically-resistant epoxy resin. The surface should be nonporous and resistant to the acids, solvents, and

chemicals used in conjunction with the filtered hood. The work surface should also contain a dished recessed area for containing primary spills.



**Warning:** It is important to support the rear of the work surface and filtered hood. The cross support provides support for the bottom of the work surface. Install the cross support after the base cabinets and work surface are leveled and before installing the filtered hood.

**Avertissement:** Il est important de soutenir l'arrière de la surface de travail et filtré hotte. Le support transversal soutient le bas de la surface de travail. Installer le support transversal après que les meubles et la surface de travail soient nivelés et avant d'installer la hotte.

Figure 4-2

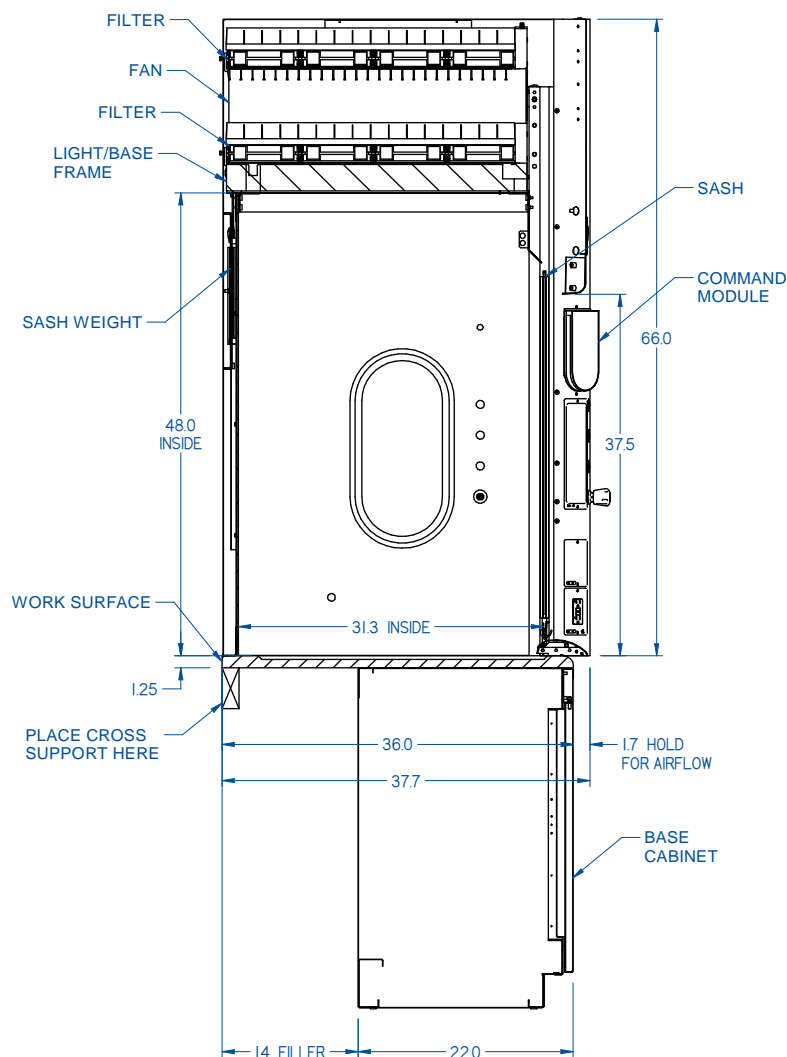

The following are instructions for mounting a cross support:

1. Level the base cabinets and the work surface. The filtered hood should be placed flush with the back of the work surface as shown in Figure 4-2.
2. Scribe a line on the wall or back of the base cabinet to locate the support under the work surface.
3. Mount the support by attaching it to the wall or base cabinet.
4. Place the filtered hood on top of the work surface and cross support.

## Step 2

Prior to connecting any electrical wiring to the filtered hood structure, refer to the filtered hood serial tag for the proper electrical requirements of your specific model. Serial tag location is shown in Figure A-1 of [Appendix A: Parts List](#).



**Warning: The building electrical supply system for Protector Hoods should include overload protection. A switch or circuit breaker should be in close proximity to the equipment and within easy reach of the operator. The switch or circuit breaker is to be marked as the disconnecting device for the equipment. Consult the current version of NFPA 70®, NEC® for proper installation.**

**Avertissement: Le système d'alimentation électrique de la Hotte Protecteur doit inclure la protection contre la surcharge. Un commutateur ou disjoncteur doit être tout près de l'équipement et à portée facile de l'opérateur. Le commutateur ou le disjoncteur doit être marqué comme l'appareil débranchant pour l'équipement. Consultez la version actuelle de la norme NFPA 70®, NEC® pour une installation correcte.**

The serial tag, model number, serial number, and electrical connection boxes are accessible from the front of the filtered hood by removing the front panel. Check the serial tag behind the front panel for voltage verification. The number of circuits varies depending on the model. All of the electrical connections for the individual duplexes are terminated at the single point internal junction box for hook-up by a qualified electrician. If needed, the individual duplexes can be converted for instant attachment to a wall outlet by a qualified electrician by ordering 115V harness 9582710 or 230V harness 9582720. The main power to the control panel, fans, and lights uses less than 3 amps and a main power cord is included for instant attachment to a wall outlet. The single point internal junction box is used for the connection of the duplex outlets. Refer to the wiring diagram for the filtered hood in [Appendix C: Specifications](#).

The filtered hood is required to be grounded to the MAINS protective earthing ground for safe operation. Using a ring terminal sized for a #10-24 machine screw, connect the MAINS ground conductor to the grounding lug marked with the protective earthing symbol. Only MAINS ground conductors should be connected to the protective earthing ground lug, no other conductors should be connected to this grounding lug. Using wire nuts, connect the MAINS supply conductors to the filtered hood supply wires. Ensure that the wires are connected as per the appropriate wire color codes for the input voltage. For 115V Phase (Hot) is black and Neutral is white, for 230V Phase1 is brown

and Phase2 is blue. Refer to the wiring diagram for the filtered Hood in [Appendix C: Specifications](#).



**It is recommended all wiring for the filtered hood be performed by a licensed electrician and conform to all local codes.**

**Il est recommandé que tout le câblage de la hotte filtrée soit effectué par un électricien agréé et conforme à tous les codes locaux.**

### Step 3

The filtered hoods with service fixtures have been plumbed from the valve to the hose connector or gooseneck for your installation convenience. Supply tubing shall be provided by the qualified installer. Tubing can enter the filtered hood from above, through the back, or through the work surface to make these connections to the service fixtures.



**Note:** Inspect all fittings for leaks. Tighten the fittings slightly if necessary.

**Remarque:** Inspectez tous les raccords pour les fuites. Serrez légèrement les raccords si nécessaire.



**Caution:** Do not use oxygen with any standard service fixture. Contact Labconco Customer Service for oxygen fixture information.

**Prudence :** Ne pas utiliser de l'oxygène avec l'accessoire de service standard. Contacter le Service Clientèle de Labconco pour les informations d'accessoire d'oxygène.

Should access to the filtered hood plumbing fixture bodies be required, remove the service access plate on the filtered hood front corner posts by loosening their individual screws (see item 8 of Table A-1 in [Appendix A: Parts List](#)). The valve body will now be fully exposed for any service work that may be necessary. The service fixtures supplied on the filtered hood are designed for use with the following services:

- Air
- Cold Water
- Hot Water
- Natural Gas – See cautions below
- Vacuum



**Warning:** Contact Labconco Customer Service directly before using any service other than those listed above in these valves to assure full compatibility.

**Avertissement:** Contacter le Service Clientèle de Labconco directement avant d'utiliser n'importe quel service autre que ceux énumérés au-dessus dans ces soupapes pour assurer une pleine compatibilité.



**Caution:** Natural gas should be used only in the service fixture that has been plumbed with brass tubing. Sulfur content of the gas could cause deterioration of standard copper supply lines.

**Prudence:** Le gaz naturel devrait être seulement utilisé dans l'accessoire de service qui a été pré soudé avec des tuyaux de cuivre. Le contenu soufré du gaz pourrait causer la détérioration des lignes d'alimentation en cuivre standard.

#### Step 4

When the filtered hood has been set in place, wired, and plumbed, it should be sealed at the work surface to prevent spilled materials from collecting under the walls of the filtered hood. Materials such as silicone sealants are recommended to seal the hood structure.

### Filter Installation

This section will detail how to install and check the filtration for the hood, including detailed figures and pictures (all figures will be shown for M3 or 5FT filtered hood). If using the HEPA filter option, reference [Section 8: Maintaining your filtered hood for HEPA filter installation and replacement](#). This section describes how to:

- Confirm order and check supplies.
- Locate the power supply, command module and anemometer
- Unpacking pre-filters, filters and fan boxes
- Place pre-filters and stack on primary filters
- Stack fan boxes on primary filters
- Place secondary filters on fan box
- Label all filters and fan boxes
- Add protective caps to secondary filters

#### Step 1



Collect the following tools required to install the equipment:

- 6ft ladder
- Tape and a marker
- 2 people required

#### Step 2

To confirm your order, make sure you have the correct number of fans for the filtered hood size:

- M1 (1 column filtration) 3ft Protector Airo
- M2 (2 column filtration) 4ft Protector Echo/Airo
- M3 (3 column filtration) 5ft Protector Echo
- M4 (4 column filtration) 6ft Protector Echo
- M5 (5 column filtration) 8ft Protector Echo

#### Step 3

Each Protector Hood will have the following Neutrodine filters based on their size per each filtered hood installed.

- M1 (1 column filtration) 2 total Neutrodine filters

- M2 (2 column filtration) 4 total Neutrodine filters
- M3 (3 column filtration) 6 total Neutrodine filters
- M4 (4 column filtration) 8 total Neutrodine filters
- M5 (5 column filtration) 10 total Neutrodine filters

#### Step 4

Make sure that you have located the power supply cord to attach power to the wall. If needed, the inlet power may be hard wired at the internal junction box.

#### Step 5

Locate the pre-mounted controller on the right corner post, the power supply box and the anemometer on the left side of the filtered hood. These components have been pre-mounted for convenience.

#### Step 6

Unpack all of the Neutrodine filters for the filtered hood you are commissioning. Keep track of all parts. The Neutrodine filters are shipped separately from the filter manufacturer to the job site. Remove all packing material, lay them flat and stack them out of the way of the front of the filtered hood but near it.

**Figure 4-3**

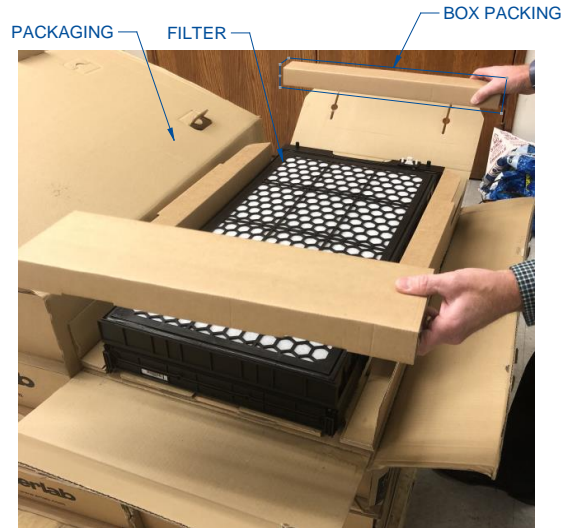

#### Step 7

On top of the base frame (factory installed and shown in Figure 4-4), place the white pre-filter in the basket of the frame. Ensure the pre-filter is center and flush as possible.

### Step 8

With the pre-filter in place you are ready to install the first Neutrodine filter.

1. Start with the column closest to the command module on the right corner post shown in Figure 4-4.
2. Place the rear bottom rails of the filter on the track of the base frame (Figure 4-5) and slide back until you hear a click.

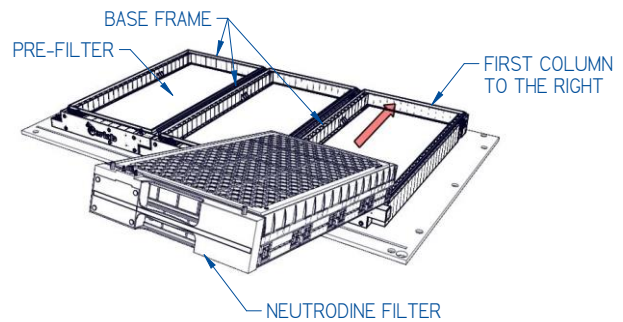

Figure 4-4

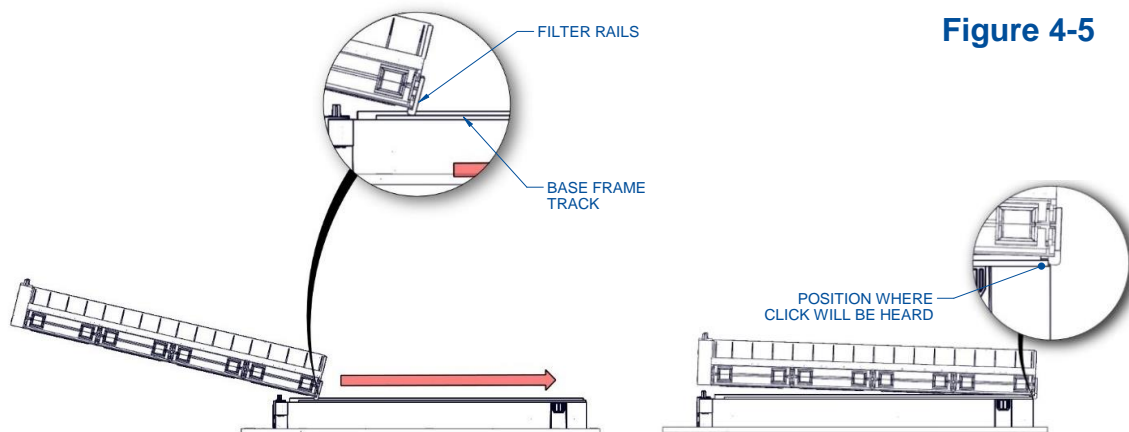

Figure 4-5

3. Once the filter is in place, lower the front end on to the base frame completely (Figure 4-6). Use the two locators shown to help line up the filter on the base frame. Connect the base frame cable to the female port on the filter face plate.

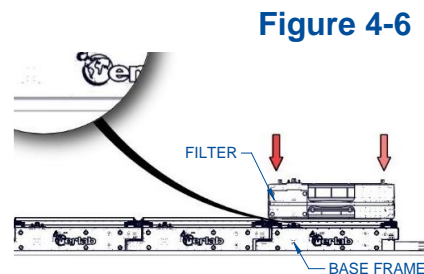

Figure 4-6

### Step 9

Make sure the filters are properly seated on all sides of the base frame. When you are done placing, use a piece of tape and marker to label the filter's position. If the filter is placed first down (directly on top of the base frame) and in the first column (the one closest to the command module) the tape label will say "1P" for 1<sup>st</sup> column and primary filter. If the filter is first placed in the 3rd column away from the command module, the label will say "3P". The filter in Figure 4-6 is in a primary filter position.

### Step 10

Repeat steps 7, 8 & 9 with all the primary filters needed for your size of filtered hood.

### Step 11

Now place the fan box (previously removed from the packaging) on top of the Neutrodine filter. Make sure the fan motor is up and the Erlab logo on the front is facing the right way (so you can clearly see the 'e' is not upside down). Locator poles on the filter should line up with locator holes on the fan box as shown in Figure 4-7. Take care to ensure a good electric connection with the male and female plugs.

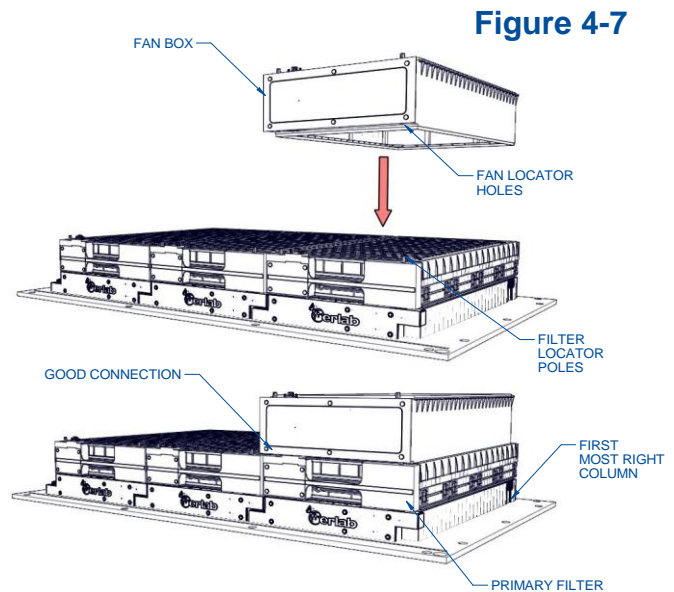

**Note:** If using an acid or formaldehyde sensor, the fan box with the sensor will be labeled with an 'A' for acid or an 'F' for formaldehyde. Place this fan box in the location shown in Figure G-1 of [Appendix G: Acid/Formaldehyde Sensor Locations](#).

### Step 12

Once in place, label the fan boxes according to the column they are in. The only label needed on the tape is the number of the column the fan box is sitting in.

### Step 13

Repeat steps 11 & 12 with all the fan boxes needed for your size of filtered hood.

### Step 14

With the primary filter and fan box in place you are ready to install the secondary Neutrodine filter.

1. Start with the column closest to the command module on the right corner post shown in Figure 4-8.
2. Place the rear bottom rails of the filter on the track of the fan box and slide back until you hear a click.
3. Once the filter is in place, lower the front end onto the base frame completely (Figure 4-8). Use the two locators shown to help line up the filter on the base frame. Connect the base frame cable to the female port on the filter face plate.

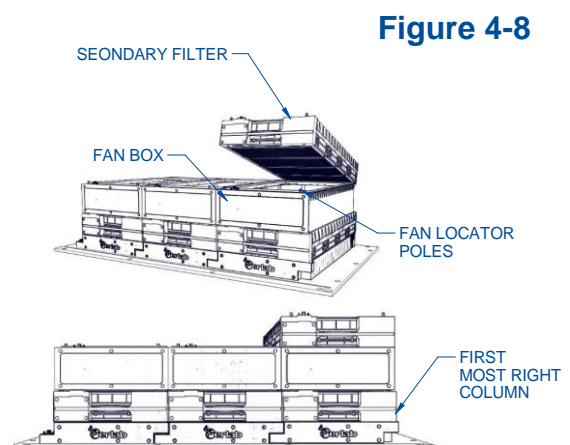

### Step 15

Make sure the secondary filter is properly seated on all sides of the fan box. When all secondary filters are in place, use a piece of tape and marker to label the filter's position. If the filter is placed in the first column (the one closest to the command module) the tape label will say "1S" for 1<sup>st</sup> column and secondary filter. If the filter is above the fan in the 3<sup>rd</sup> column away from the command module, label it "3S".

### Step 16

Repeat steps 14 & 15 with all the secondary filters needed for your size of filtered hood.



For a 5FT (M3) filtered hood example of what the completed filter installation looks like including column labels see Figure 4-9. Your filtered hood should be stacked and labeled like Figure 4-9. Caps should be on top of all the secondary filter's connections to protect them. The command module side is called out for reference.

Figure 4-9

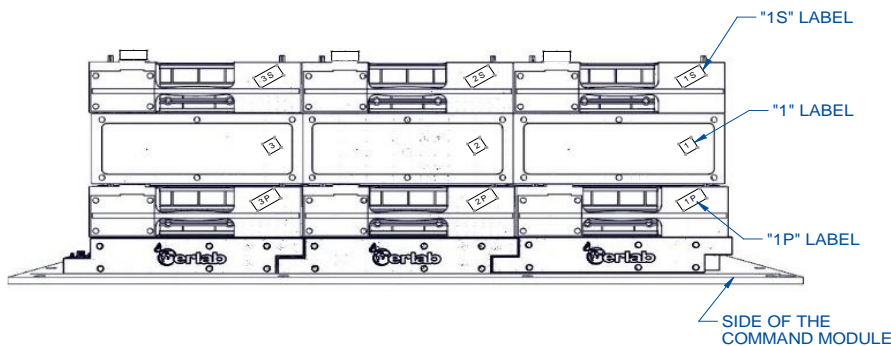

## Calibrating the Airflow Sensor

Airflow sensor calibration is required for safe operation of the filtered hood. The calibration is important for the function of the filtered hood and should be repeated frequently. An annual calibration is recommended to ensure accuracy while in use. The entire process will take about 5 minutes to complete. Always make sure no wiring, plumbing or power cords are blocking the inlet of the sensor. **Always calibrate with both side panels installed to prevent cross drafts near the airflow sensor.**

### Step 1

Turn the filtered hood on. The lights and fans should be working properly with no errors.

Figure 4-10

### Step 2

With the filtered hood powered, move the sash to your desired working height. It is recommended to be 2 to 3 inches above the working height to avoid nuisance alarms due to room pressure changes. Once in place, DO NOT move the sash until the calibration is completely over.

### Step 3

Turn the fans off by pressing [**Fan ON/OFF**] on the front of the command module.

### Step 4

For 10 seconds, hold the [**Power Button**] down. This will cause the maintenance and containment icons to appear in red on the front of the command module. The appearance of the command module will match Figure 4-10 with the fan icon blinking.

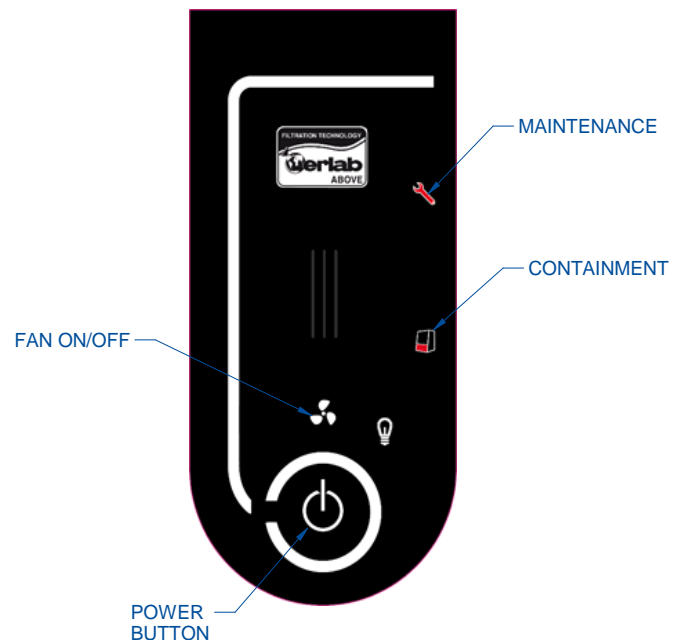

### Step 5

With the command module as shown in Figure 6-1 (with the Command Module Signature Light blinking), press the Fan ON/OFF button to start calibrating. This will begin the configuration process.



**Note:** After step 5 do not attempt to operate the filtered hood or move the sash from the working position. Any changes made during the calibration process will cause inaccuracies in the calibration. The following steps require no action.

### Step 6

With the fan(s) off the filtered hood will stabilize for about 30 seconds and an audible chime will be heard from the command module to signal the filtered hood is completely stable.

### Step 7

In a stable filtered hood with the fan off, the anemometer will take readings for about a minute and calculate the zero (no airflow) value. Once complete, another chime will play.

### Step 8

The fans will automatically start and the lights inside the filtered hood will turn off. Again, the filtered hood will stabilize and chime when ready, which should be about 30 seconds.

### Step 9

In a stable filtered hood with the fan on, the anemometer will take readings for about a minute and calculate the approximate 80 fpm (or approximate 0.4m/s) value. Once complete, another chime will play and the Maintenance and Containment icons will shut off.

### Step 10

The last chime also signals that the entire filtered hood will then turn off.

Now that the filtered hood is off, the calibration is complete. If the settings for the fan are ever changed, for example if the working and/or closed set point are moved, the anemometer airflow sensor must be recalibrated again. *If receiving nuisance alarms, adjust the calibration sash position and try again. You may need to calibrate several times before successfully calibrating the filtered hood.*

### Step 11

For first time installations or filter changes, the maintenance alarm (wrench icon) will appear due to the command module recognizing new equipment. This is to be expected and the alarm must be cleared by holding the mute alarm button (speaker icon) for two seconds.

## Certification

The filtered hood is designed for inflow velocity between 60 - 100 fpm (0.31 – 0.51 m/s). Lower inflow velocities are possible by raising the sash position, and higher inflow velocities are possible by lowering the sash position. The filtered hood should be certified at a sash position that correlates to the required inflow velocity, and using assessment protocol according to your organization's Chemical Hygiene Plan (OSHA, CFR 29, 1910). In the absence of a Chemical Hygiene Plan, the Chemical Hygiene Officer should reference ANSI/AIHA/ASSP Z9.5 for risk assessment and to establish pass/fail criteria, and ANSI/ASHRAE 110 for certification test methodology. This should include, but is not limited to:

- Airflow Velocity Testing
- Smoke Testing to assess airflow patterns and containment

## Re-Certification

The filtered hood should be recertified as directed by the Chemical Hygiene Plan, but at least annually.

## 5: Performance Features

---

Labconco has combined its patented (U.S. Patent No. 6,461,233), containment-enhancing Protector Hood design with Neutrodine filtration technology to deliver a multi-use fume hood that requires no ducting. The filtered hood provides safety, energy savings, and adaptability to ever-changing lab spaces.

The filtered hood is designed to meet the needs of the laboratory chemical hygiene plan with velocities from 60 to 100 feet per minute. The filtered hood has been designed to effectively contain toxic, noxious, or other harmful materials when properly installed. The by-pass feature with Neutrodine universal filter technology enables this filtered hood to maintain safe airflow with excellent filtration efficiency.

Airflow is diverted behind the front panel and under the air foil to help control fluctuations in face velocity, which occur as the sash is closed. The filtered hood is SEFA 9 compliant as a DH3 for ductless hoods and ductless enclosures with back-up safety filters.

### Directional Airflow

Directional airflow also plays a key role in filtered hood performance. Air is drawn into the sash opening of the filtered hood. The angled corner posts, sash handle and front airfoil are all made to assist the air being pulled away from the worker, into the filtered hood and through the filters. This movement of air makes it more difficult for aerosols to escape out of the filtered hoods work area and into the laboratory environment. This airflow is often calculated and referred to as the Inflow Volume or Average Inflow Velocity.

### HEPA Filters

An optional HEPA filter is available for this filtered hood. HEPA filters are disposable, dry-type particulate filters. The filter material or media is typically made of borosilicate microfibers formed into a thin sheet, in a process similar to the production of paper. This sheet is folded, or pleated to increase its surface area. The pleats are typically held in place by beads of glue that add rigidity to the media pack. The pack is then set into a frame, and sealed.

The HEPA filter manufacturer establishes the efficiency of the filter by challenging it with an aerosol of known particle size. The number of particles that penetrate the filter are quantified, and this establishes the efficiency of the filter.



**Note:** HEPA filter media is very fragile. DO NOT touch the media. If you think the media of a HEPA filter is damaged, DO NOT USE THE FILTERED HOOD. Have the HEPA filter integrity tested by a certifier before using the filtered hood.



**Note:** HEPA Filters are only effective against particulate material. Gases and vapors will pass through the filter.

## Neutrodine® Filters

Neutrodine filtration takes the guesswork out of carbon filter choices allowing simultaneous handling of solvents, acids and bases with one comprehensive filter. The backup (secondary) filter provides added safety after breakthrough and until filter change can occur. Sensor package detects filter saturation and sounds an alarm when unsafe conditions are detected. Intelligent filter identification indicates type (HEPA or Neutrodine) and status (primary or secondary) to prevent saturated filter reinstallation risk. Available with eGuard software to monitor, manage and provide data via Wi-Fi or Bluetooth connection to a phone, tablet or computer. Make sure to use only what was reported in the approved LP questionnaire for safety purposes.

## Fan/Motor

The fans, positioned between the two Neutrodine Filters, pull air from the room through the sash opening of the filtered hood, through the filter protection and out the top of the hood. By passing through both the primary and secondary filters, the air is clean provided no alarms are present and all safety precautions are followed. The fans have an operation range of 1,000 rpm to 3,000 rpm with two speed settings. In the eGuard interface you can manipulate the speed of the fan when the sash is at operating height and closed.

It is suggested that you keep the rpm settings no lower than 1,400 rpm for the Closed Setpoint and no higher than 2,400 – 2,600 rpm for the Working Setpoint (operating height). If your filtration technology includes a HEPA filter, the Working Setpoint suggested is 2,600 – 2,800 rpm. See [Appendix D: eGuard](#) for more information.

## Front Airfoil

The location, size, and pattern of the airfoil openings in the work area affect filtered hood containment and performance. The front airfoil profile, and air intake openings play an important role in establishing Directional Airflow, as described previously. A flush foil is also available as a factory installed custom only. The air foils feature Clean-Sweep™ openings that create a constant barrier from contaminants. In addition, should the operator inadvertently block the airfoil holes, the air continues to enter from under the air foil and through the Clean-Sweep openings.

## Work Area

Large usable interior work depth and interior Echo height of 48 inches (Airo 36 inches) provides ample working space. Available in 37.7-inch depth and 4', 5', 6' and 8' widths. 3' only available in 31.7-inch depth. Spillstopper™ Solid Epoxy Work Surface, reference [Section 9: Accessories](#), is dished to contain spills (work surface sold separately). Fully-closing, vertical-rising sash opens to 28 inches high for Echo loading (26 inches for the Airo). Energy efficient LED lighting is located in the top of the work area. The factory installed-instant start LED lighting is located in the base frames of the filtration columns.

## Internal Service Lines

Streamlined corner posts provide maximum visibility and the flexibility to add services after installation. Duplex electrical receptacles are mounted on the right and left corner posts as requested. Receptacles are factory-wired to the filtered hood's single point junction boxes. The filtered hood accommodates up to four electrical duplex receptacles and eight services fixtures. These service lines and electrical duplexes are outlined in [Section 9: Accessories](#) as options to be added. Also available are sash stops, distillation grids and sash reduction wing kits.

## Anemometer (Airflow Sensor)

The filtered hood includes a sash position alarm and a velocity alarm should the fan speed drop. Located in the side wall of the filtered hood, the calibrated sensor will measure the filtered hood for safe airflow. If the airflow drops below safe levels, the filtered hood will go into alarm. A low face velocity error will display on your command module and through the eGuard connection. The airflow sensor must be calibrated before first use and at least annually. To see this process, reference step 8 of [Section 4: Installation \(calibrating the airflow sensor\)](#). To replace the sensor, see [Section 8: Maintaining your filtered hood \(Airflow Sensor Replacement\)](#).

## 6: Filtered Hood Operating System

The filtered hood operating system provides user control with the touch pad command module and a wireless interface called eGuard. eGuard connects the filtered hood's command module to the user's phone, laptop or tablet either through an Ethernet cable wireless (Wi-Fi or Bluetooth) connection.

### Command Module

Figure 6-1 shows the front face of the command module with identified buttons and icons:

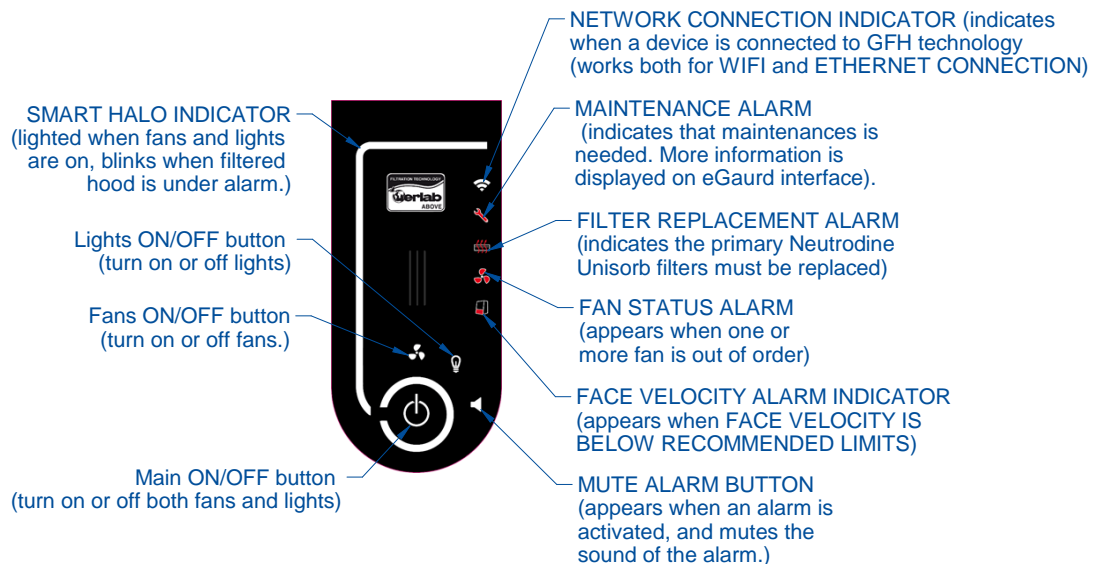
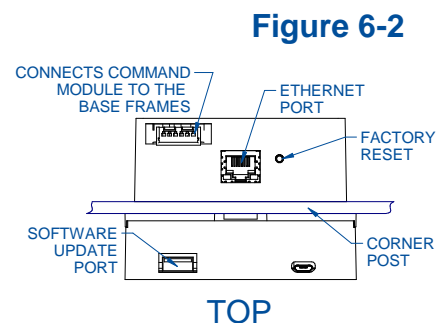

Figure 6-2 shows the top of the command module. The software update port is a suitable for a USB and is used for Erlab implemented updates. All features "behind" the corner post bar (like the Ethernet port, factory reset, etc.) is not visible without removing the right-hand side panel.





## Connecting to your filtered hood

For connecting your phone or tablet to the filtered hood:

1. Open the network selector on your device.
2. Select the Wi-Fi network: **GFH-XXXX-XXXX** (the **XXXX** is the serial number of the filtered hood).
3. Password is: **GFH-2018**
4. Open an internet browser (Google Chrome, Mozilla Firefox... etc.) and enter the following address in the address menu: <http://192.168.1.1>

This will open a webpage that is the eGuard home screen.

For connecting the filtered hood to a laptop:

1. Connect an Ethernet cable to the laptop from the command module.
2. Select or type the following parameters:
  - a. Protocol TCP/IP V4
  - b. IP address: 192.168.0.201
  - c. Subnet mask: 255.255.255.0
3. Open an internet browser (Google Chrome, Mozilla Firefox... etc.) and enter the following address in the address menu: <http://192.168.0.205>
4. See Figure 6-3 for more details.

Figure 6-3

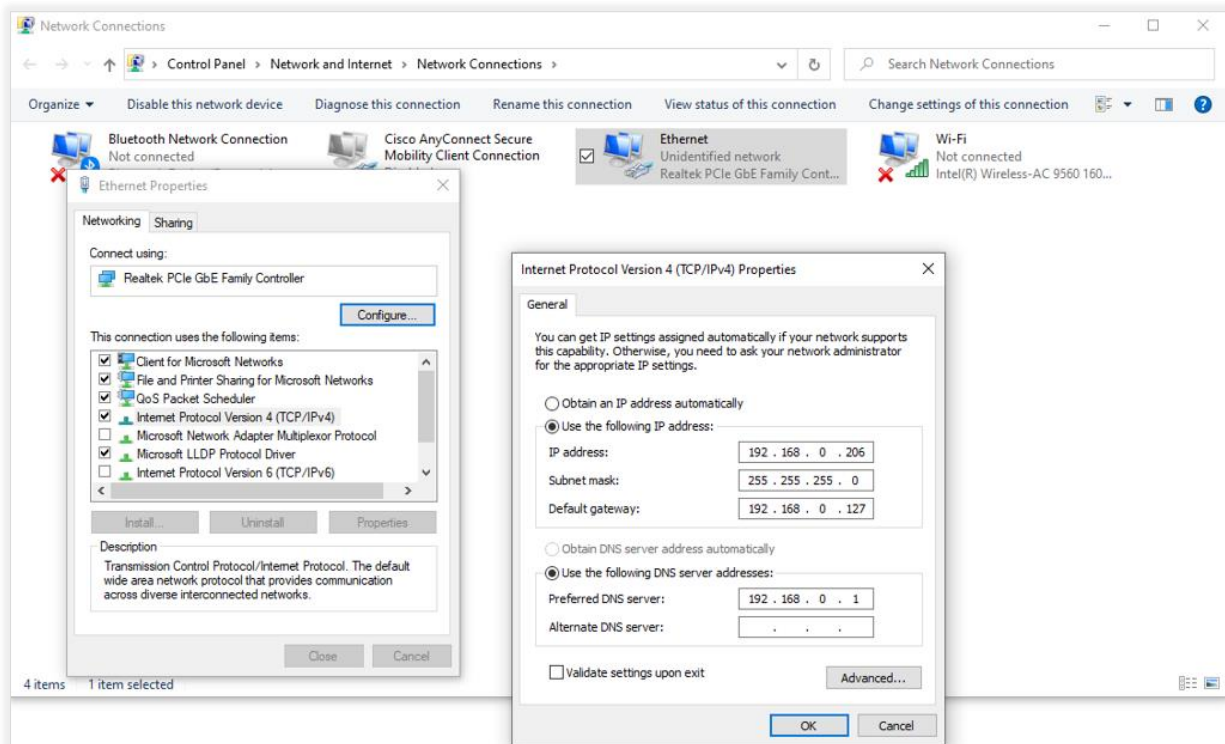

## eGuard

The homepage (shown in Figure 6-4) has three sections titled INFO, LOGS and SETTINGS. The Name and serial number of the filtered hood is always shown here as well.

INFO displays the usage time of the filtered hood, and the safety state of the following categories: Face Velocity, Fan, Filtration and Maintenance. When the ventilation is off, the dots beside these categories are gray. Once the ventilation is activated and the filtered hood is running correctly, the dot turns green.

LOGS has record of this filtered hood's specific event history and will keep track of alarms and power ups and downs of the filtered hood.

Finally, SETTINGS is the last option of the eGuard homepage. This page requires a username and password to enter. The sensor sensitivity should be adjusted to match the LPQ solvent chemical sensitivity assigned to your filtered hood. The airflow sensor sensitivity can also be adjusted. Other sensors like the temperature trigger range, humidity trigger and light and sound intensity is found under the settings page.

To see more in-depth use of the eGuard software, see the [Appendix D: eGuard](#).

Figure 6-4

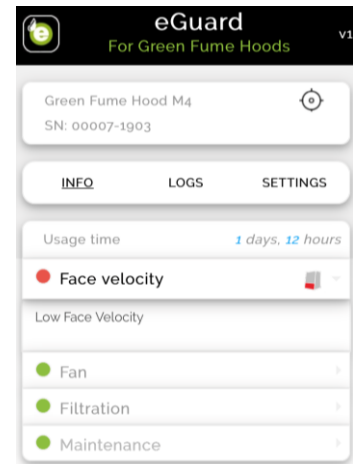

## Alarm Screens

When in alarm, the sides and front Smart Halo Indicator of the Command Module will flash, as well as an audible alarm can be heard coming from the Command Module. An icon will appear on the front of the Command module to give some insight as to what the error may be. In addition, the mute alarm button will illuminate. Press the Mute Alarm Button for the audible alarm to stop (this will not fix the problem nor will the flashing Smart Halo Indicator stop). Ten minutes after the mute button has been pressed, the alarm will resume making noise if the error has not been resolved.

For more information on root cause and diagnosis for the alarm, open the eGuard homepage. From the INFO portion of the eGuard home page, an error in the filtered hood by the category with a red dot, rather than green for normal operation. Click the drop down arrow of the category with the red alarm dot to display the error code.

For example, the Face Velocity category has a red dot beside it and an alarm icon that matches the alarm which would show on the Command Module. After clicking the drop down arrow you can see in Figure 6-4 the message reads 'Low Face Velocity' which means the air being pulled from the surroundings into the filtered hood and through the filters is lower than recommended. This alarm is most commonly seen when the sash is fully open and can usually be fixed by simply lowering the sash height. More troubleshooting can be seen in [Section 10: Troubleshooting](#).

The only way to safely and permanently stop the filtered hood from being in alarm is by solving the problem. Once the error is resolved, the alarm icons, flashing lights, and eGuard descriptions will go away.

## 7: Using Your Filtered Hood

This section details the functional features and proper techniques for safely and efficiently using the filtered hood.

### System Reset

A reset, normally not required, may be needed if the filtered hood IP address and/or password was changed and forgotten. There are two ways to reset:

#### Reset with eGuard

To conduct a factory reset using eGuard, follow the steps in [Appendix D: eGuard](#). The steps will be as follows:

1. Connect to eGuard and open a web browser
2. Type <http://192.168.1.1/update.html> in the browser menu and you will be prompted for a username and password
3. Username: **ach** Password: **ach**
4. Scroll until you find the Reset section shown in [Figure 7-1](#)
5. Touch the green button **[Reset]** for the process to begin.

Figure 7-1



#### Manual Reset Switch

Remove the right side panel of the filtered hood (shown in [Figure 7-2](#)) by lifting and moving backwards away from the filtered hood. Once removed, look at the top of the command module behind the corner post. Locate the small hole shown in [Figure 7-3](#). Insert a small pointer (pen, small tool, bent paper clip, etc.) into the reset hole. This will return the filtered hood to its default values.

Figure 7-2

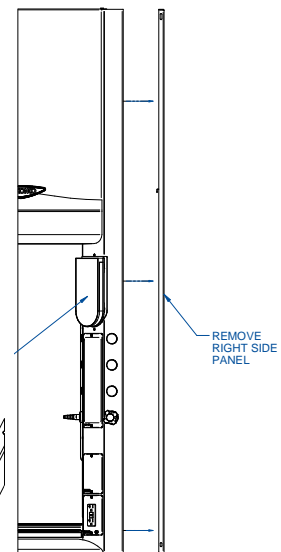
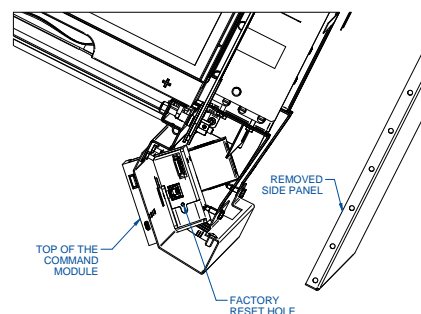

Figure 7-3



For reset default values, see [Appendix D: eGuard](#).

## Sash Operation

Because of the filtered hood counterbalanced sash mechanism, it will take only a few pounds of force to move the sash up or down, and you can operate the sash smoothly with one or two hands positioned anywhere along the handle. The vertical-rising sash may be raised to a maximum 16-inch operating height for proper airflow between 60-100 fpm. The airflow requirements should be sized for the 16-inch operating height. The sash stops allow the Echo sash height to be increased to 28 inches (26 inches for Airos) only for loading equipment.

## Controls

All controls can be found on the Command Module as described in [Section 6: Filtered Hood Operating System](#). The buttons on the command module, visible only when available for use, allow control of the filtered hood. These are illustrated in Figure 7-4.

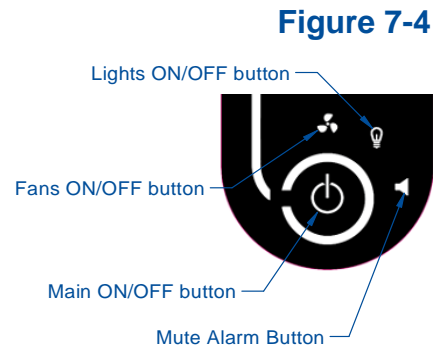

## Fans

The fans turn on automatically when powering on the filtered hood. To turn them off, press the **[Fans ON/OFF]** button found on the face of the command module. To resume fan operation in the filtered hood, press the **[Fans ON/OFF]** again.

## Lighting

The internal filtered hood lights are LED and work identically as the fans. They will automatically turn on with the first power up of the filtered hood. They can be turned off and on independently of any other action by pressing the **[Lights ON/OFF]** icon on the command module.

Pressing **[Main ON/OFF]** on the command module will turn off the Smart Halo Indicator lights of the command module, and will turn off the fans and lights simultaneously.

## Airflow Sensor

Airflow is automatically controlled by the command module of the filtered hood. If you want to change the rpm of the fans to get a desired face velocity or dwell time, see the [Appendix D: eGuard](#) for this product. If you believe the airflow sensors are not correctly calibrated, see [Section 4: Calibrating the Airflow Sensor](#).

## Mute Alarm

This button controls the alarms that sound. To stop an alarm sound press the **[Mute ON/OFF]** button. This will not dismiss the alarm, just the noise. After 10 minutes, if the issue is not resolved, the alarm sound will begin again. For

information on decreasing the volume of the alarm see [Appendix D:eGuard \(Others\)](#).

### Outlet (Optional)

If optional outlets found on the filtered hood are electrically connected, they will operate even if the filtration technology is not currently turned on.

### Start-up

1. To begin, make sure the filtered hood is plugged in. You will hear the power up chime when it is ready to operate.
2. Once the filtered hood is ready, press the **[Main ON/OFF]**. This will turn on both the lights and the fans. You can validate performance by listening for the fans and seeing the internal lights are on.
3. On your phone or tablet, open up eGuard and double check all technology is working properly.

### Loading Product / Materials

- Only load the materials required for the procedure. Do not overload the filtered hood.
- Do not obstruct the front air foil.
- Large objects should not be placed close together. Place large objects on a short stand to elevate them above the work surface. This permits airflow to sweep under the equipment.
- After loading the filtered hood, wait one minute to purge airborne contaminants from the work area.

### Work Techniques

- Keep all materials at least 6 inches inside of the sash, and perform all contaminated operations as far to the rear of the work area as possible.
- Segregate clean materials from contaminated materials in the work area.
- Avoid using techniques or procedures that disrupt the airflow patterns of the filtered hood.
- The filtered hood exemplifies robust heat tolerance (up to 5-degrees C above the room ambient temperature) from hotplates, ovens or other heat generating equipment below 1058 watts or below 300-degrees C surface temperature; avoid the use of heat outside any of these limits inside the filtered hood. See [Appendix D: eGuard - Settings, Other Sensors](#), to change the temperature trigger value 1.



### Unloading Product / Materials

- Objects in contact with contaminated material should be surface decontaminated before removal from the filtered hood.

- All open trays or containers should be covered before being removed from the filtered hood.

## Shutdown

- It is recommended there is a thorough decontamination prior to powering down the fans and filtered hood.
- Press **[Main ON/OFF]** on the command module. This will turn off the fans and lights.
- With fans and lights off, close the sash and leave the filtered hood until next use.

## 8: Maintaining Your Filtered Hood

---

This section details the maintenance required for optimal operation of the filtered hood.

### Maintenance Safety Precautions



The following tools and supplies are required to maintain the equipment:

- #2 Phillips Screwdriver
- Suitable dish soap, solvent, disinfectant, or cleaner
- Paper Towels or clean cloth



The following safety precautions must be followed by all personnel maintaining the equipment.

- Wear safety glasses, and/or additional eye and face protection as required by your Health & Safety Department.
- Wear gloves, and/or additional skin protection as required by safety instructions for cleaning/disinfecting chemicals used. Consult your Health & Safety Department for additional skin protection requirements.
- No loose fitting clothes
- Wear close-toed shoes
- Although the service operations detailed in this section do not involve access to areas of the product with moving or electrical parts, should you remove any panels that expose moving or electrical parts, you must follow these instructions before doing so:



- Disconnect main power cord or electrical service connection
- Never touch moving parts such as fan blades or blower wheels.



Never touch the optional HEPA filter. Touching the media will damage it, and result in a failure of the filter to function properly and maintain safe conditions.

## Recommended Maintenance Schedule

Table 8-1

Activity	Maintenance Frequency		
	Weekly	Quarterly	Annually
Wipe down interior with suitable dish soap, solvent, disinfectant or cleaner	•	•	•
Clean exterior surfaces (especially front and top) of any dust with a damp cloth	•	•	•
Operate fan system, noting airflow with source of visible smoke	•	•	•
Use calibrated anemometer or other approved apparatus to verify airflow face velocity through sash opening. Reading should be between 60 and 100 fpm.		•	•
Check light functionally. See <a href="#">Section 8: Base Frame Replacement</a>			•
Recalibrate the airflow sensor. See <a href="#">Section 4: Calibrating the Airflow Sensor</a>			•
Have the filtered hood recertified by a qualified technician. See <a href="#">Section 4: Certification</a>			•
Replace carbon filters when chemical breakthrough is indicated; see <a href="#">Section 8: Filter Replacement</a>			As needed
Replace optional HEPA filters if face velocity drops below recommended. See <a href="#">Section 8: Optional HEPA Filters</a>			As needed

### Service Operations

This section will cover:

- Front Panel Removal
- Filtration Replacement
- Airflow Sensor Replacement
- Acid/Formaldehyde sensor replacement

## Front Panel Removal

Removal of the front panel is necessary for changing the filtration technology.



Tools Required:

- 6 FT ladder



It is recommended to utilize at least two (2) persons to remove the front panel, particularly for a 6 FT and 8 FT model. The front panel is tall and heavy. Use safe lifting practices, and to set the panel where it cannot fall over while uninstalled from the filtered hood.

Removal of the front panel can be done by following these steps:

1. Place ladder up by the front of the filtered hood. Climb ladder and inspect the front panel. Make sure there is nothing that will get caught by the panel during the removal process. See Figure 8-1.
2. When you are sure there are no obstructions, lift the panel up vertically about 5 inches. This will ensure the locators holding the panel in place will have clearance over the corner posts. See Figure 8-2.
3. When free of the corner posts, the front panel should be lowered from its spot in the top front of the filtered hood to a person standing beside the ladder.
4. With the panel at a normal floor level height, the panel can be stored out of the way.

To reinstall the front panel, follow the steps 1 through 4 in reverse.

**Figure 8-1**

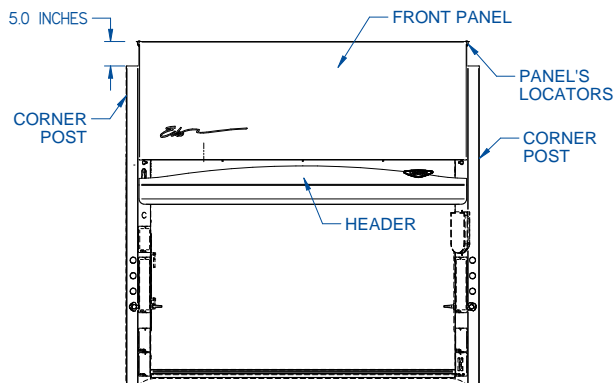

**Figure 8-2**

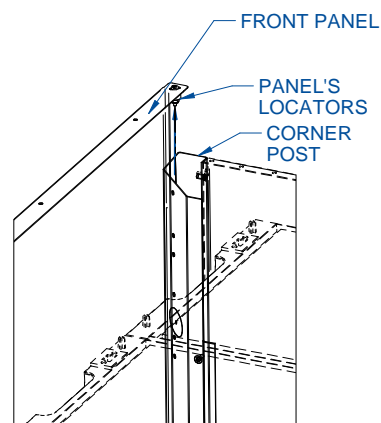

## Replacing the Filtration Technology

It is recommended to replace all filtration technology (filters, pre-filters, HEPA filters, etc.) at one time to maximize the efficiency of your time and effort. When filters need replacing, the first step will always be to order new ones. More information on available filters can be found in the [Chapter 9: Accessories](#). They are the following:

**Table 8-2**

Catalog # (10/2020 to 1/2025)	Catalog # (2/2025 to Current)	Description
9577420	9577460	Neutrodine molecular carbon filter (universal)
9577421	9577461	Optional HEPA filter
9577422	9577422	Pre-filter, located in the Base Frame



Only stock the bare minimum of Neutrodine carbon filters, the carbon filters have a shelf life and the longer they sit unused, the shorter their life span.

### Pre-filter Replacement

Pre-filters are found in the base frame of the filtered hood and the recommended replace is once a year. Up to 3 pre-filters can rest in each basket of the base frames. This section will cover how to change the pre-filters.



The following tools are required to replace the equipment:

- Phillips screwdriver
- Containment bag for used pre-filter
- Flashlight



The following safety precautions must be followed by all personnel handling the equipment and pre-filters:

- Laboratory coat
- Safety glasses, gloves and safety shoes

### Step 1

Identify the filtered hood you have and order the correct quantity for replacing. Determine your model number which is a M1 (3 FT), M2 (4 FT), M3 (5 FT), M4 (6 FT), or M5 (8 FT). These numbers are based on how many technology stacks that you have on top of your filtered hood.

- Look at the filtered hood and count the stacks of technology from left to right
- You will have 1, 2, 3, 4, or 5 stacks for 3 FT, 4 FT, 5 FT, 6 FT, and 8 FT filtered hoods.
- Match that number to M1, M2, M3, M4, or M5.
- This information will help you follow this procedure when it applies to your model M1, M2, M3, M4, M5.

Turn the fans on by pressing **[Main ON/OFF]**.

## Step 2

Access the old pre-filter from the trap door under the bottom of the filtration column. There are two clips at the front of the column. These clips may be fixed in place by two screws. Remove and save the screws, then push on the clips and pull the trap door down.

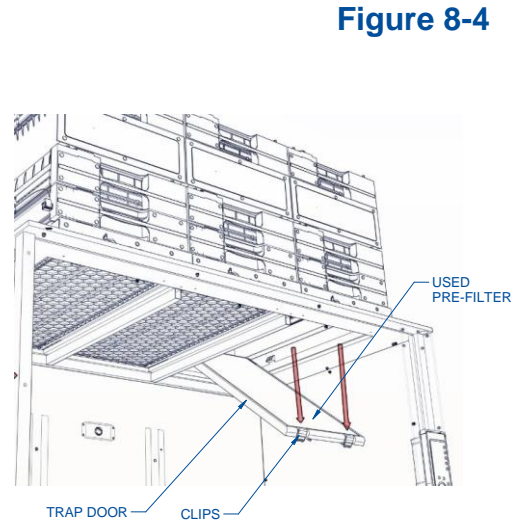
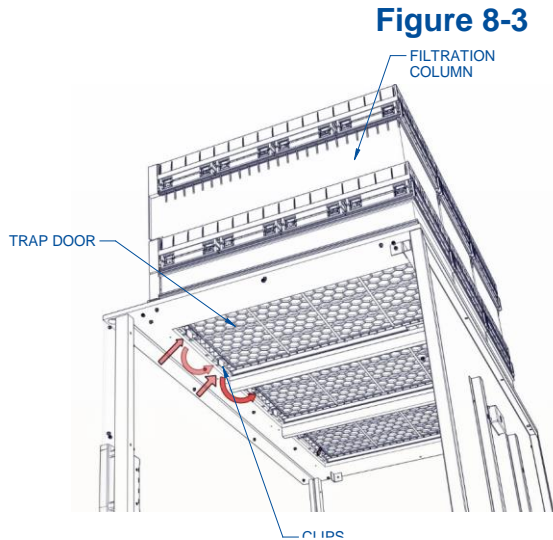

## Step 3

From here, the trap door is down and the pre-filter is exposed. Remove the pre-filter from the door.



**Caution:** If the pre-filter is contaminated by hazardous particles intercepted in filtered hood use, you must perform this with the ventilation turned on. Immediately after removal of the trap door, pack the used pre-filters in the appropriate disposal container while still inside the filtered hood.

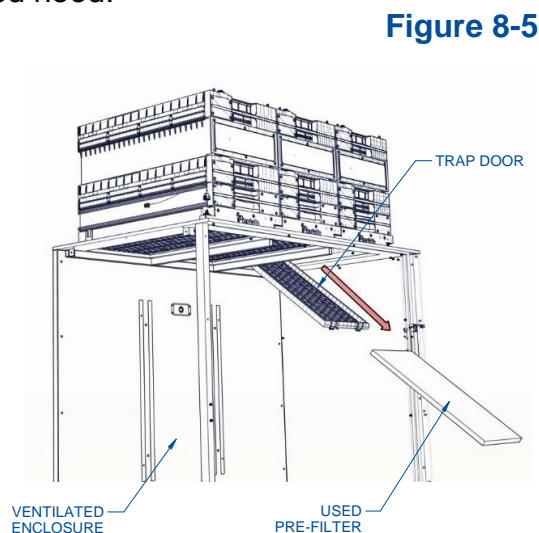

#### Step 4

Install the new pre-filter(s) in the empty trap door in place of the used one. Close the trap door and make sure the clips are secure and reapply the screws that were initially taken out of the doors. The compartment can fit 1 to 3 pre-filters at one time.

**Figure 8-6**

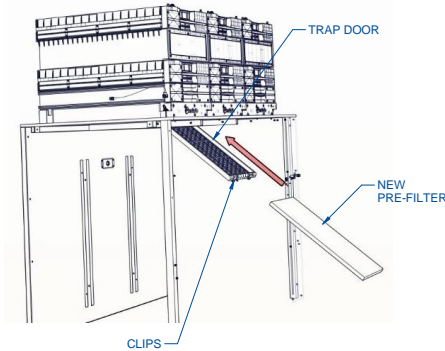

**Figure 8-7**

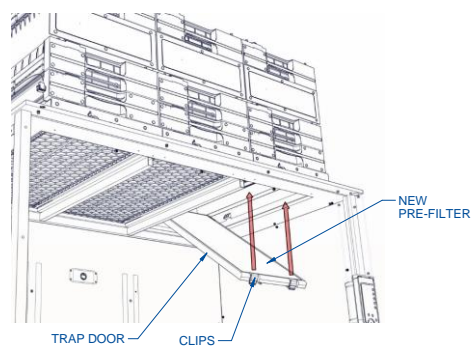

#### Step 5

Repeat steps 2 through 4 on all pre-filters of the ventilation columns that need replacing.

#### Step 6

Dispose of used pre-filters properly. Saturated filters are to be disposed of as hazardous waste. Recordings of the chemicals adsorbed by the pre-filters must be done by the user.

### Base Frame Replacement

The base frame is the bottom most layer of the filtration column. They come factory installed. The base frame holds the pre-filter as well as the LED light bar

The base frame must be replaced if:

1. The light bar buns out.
2. Damage occurs.
3. Temperature Sensor(s) need replaced.
4. Relative Humidity Sensor(s) need replaced.

This section will cover how to replace the base frames and restack the filtration technology.



The following tools are required to replace the equipment:

- 6 FT ladder
- Tape
- Marker
- 5/16-inch magnetic nut driver
- Cordless drill with 5/16-inch socket



The following safety precautions must be followed by all personnel handling the equipment and filtration columns:

- It is recommended you follow all of your existing lab safety protocols as they apply to this procedure.
- 2 persons are required for this procedure.
- Read instructions carefully before attempting.
- Disconnect power from the filtered hood.

### Step 1

Turn the filtered hood completely off and disconnect the power plug. Remove the front panel (see [Section 8: Front Panel Removal](#)) of the filtered hood and place nearby but out of the way of the filtered hood. This will expose the filtration column technology you will be working with.

### Step 2

Identify the hood you have and order the correct number of base frames for replacement. Determine your model number which is a M1 (3 FT), M2 (4 FT), M3 (5 FT), M4 (6 FT), or M5 (8 FT). These numbers are based on how many stacks of technology that you have on top of the filtered hood.

- Look at your filtered hood and count the stacks of technology from left to right
- You will have 1, 2, 3, 4, or 5 stacks for 3 FT, 4 FT, 5 FT, 6 FT, and 8 FT filtered hoods.
- Match that number to M1, M2, M3, M4, or M5.
- This information will help you follow this procedure when it applies to your model M1, M2, M3, M4, M5.

### Step 3

To unpack the new base frames, carefully remove from the boxing. Keep track of all boxes being removed. The base frames are shipped directly from the filter manufacturer to your job site. Once you've removed all packing material, lay them flat and stack them out of the way.

#### Step 4

To access the base frames, you must remove the filters and fan box above the frame, as well as the base frames, filters and fan boxes to the left of the frame being replaced. This occurs because the base frames have an interlocking connection system to limit the amount of wiring needed. The base frames are stacked such that the far right frame cannot be taken out without first removing all others. Also before removing any filters, make sure they are labeled with the column they are in, and that the filters have a P or S. For reference, see [Section 4: Filter Installation](#) for detailed direction on technology labeling.

**Figure 8-8**

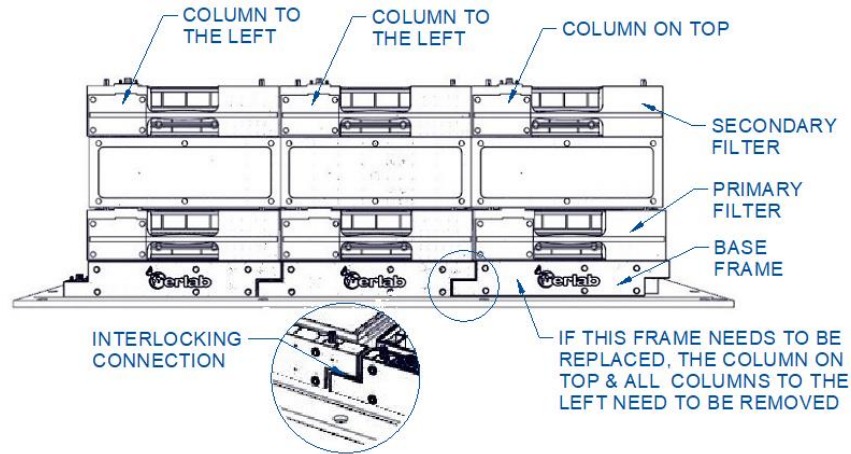

Make sure to handle the filters and fan boxes with care. Stack them near but out of the way of the filtered hood for safe keeping. Also remember the base frame is what holds the pre-filter, so handle with care and either dispose of them (and replace later) or store at this time. For pre-filter replacement see [Pre-Filter Replacement](#) previously in this section. What remains after the removal is only the base frames as shown in Figure 8-9.

**Figure 8-9**

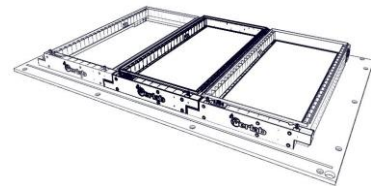

#### Step 5

Remove and dispose of the base frames. To do this, use the 5/16-inch hex nut driver and cordless drill to remove the two screws at the rear and two nuts at the front. See Figure 8-10. **SAVE THIS HARDWARE.** The hardware of every base frame being removed must be taken out and kept track of. This hardware will be used again soon.

**Figure 8-10**

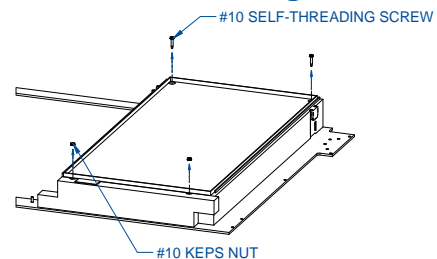

Once the hardware is removed, lift the frames (in order due to the interlocking design) and dispose of them in the correct manner.

**Figure 8-11**

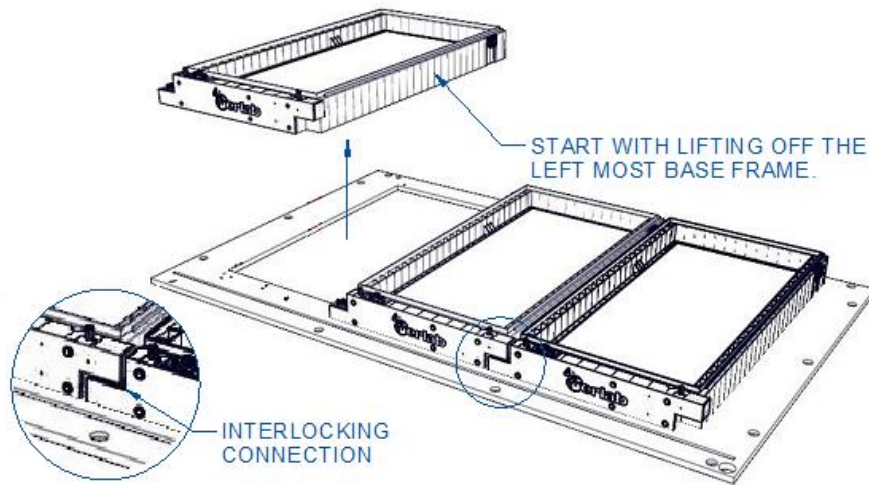

**Step 6**

Once the old is removed, unpack and place the new base frames. Start with the furthest right frame being replaced. Use the studs along the front of the top liner as locators for the front base frame holes. The base frame front holes will go on the studs. From here, use the magnetic nut driver to reinstall the nuts on the studs. The final step for this base frame is to replace the two screws along the rear of the base frame. See Figure 8-12.

**Figure 8-12**

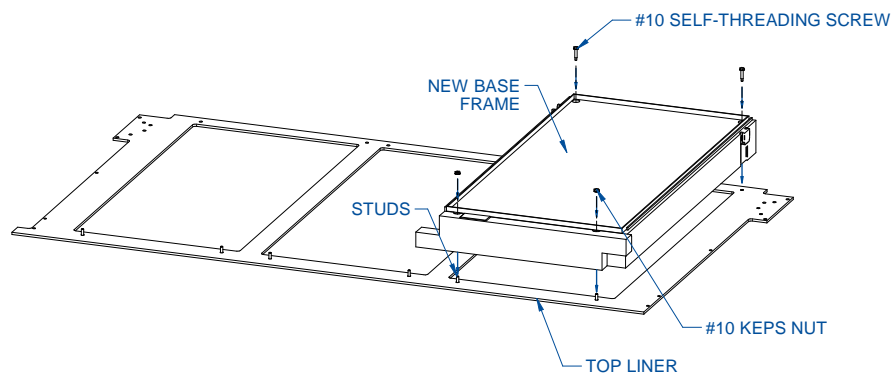

When the first base frame is secure, install the next frame to the left of it with the same steps. Ensure a good interlocking connection between each base frame until they are all in place.

**Step 7**

Restack all the filters and fan boxes removed earlier in step 4. Before replacing any Neutrodine filters or fan boxes, first check the pre-filter is in place in the basket of the

base frame. Place the filters and fan boxes, taking great care to place them back in the column they came from. Reference filter and fan box labels applied during their initial installation. For more information on how to install the filtration technology, see [Section 4: Installation \(Filters\)](#).

### Step 8

Once all filters and fan boxes are installed, all connections are verified, and no units are out of their original order, connect the filtered hood to power. Power up and check all lights and fans for proper function. If the filtered hood is in alarm, check eGuard for the explanation. If eGuard says the base frame has been replaced, press the **[mute]** button on the command module. If the alarm is anything other than a replaced message, disconnect the power, re-check all electrical connections and try again. Do not leave the filtered hood running while troubleshooting.

When properly working, reinstall the front panel and resume using the filtered hood.

### Neutrodine Filter Replacement

Filters are found above the base frame and above the fan box of the filtered hood. The primary filter (should be labeled with a 'P') is the filter between the base frame and the fan box. The secondary filter (should be labeled with an 'S') is the filter above the fan box.

The primary filters must be replaced if:

1. One of the embedded sensors (standard molecode S or optional molecode A or F) detects the presence of chemicals between the primary and secondary filters. When this occurs, a filter replacement alarm is activated and displayed on the command module and through eGuard.
2. Or the primary filters have been used for 36 months.

This section will cover how to:

- Remove front panel
- Identify your model and order new filters
- Unpack new filters
- Access the old primary filter
- Remove the old primary filter
- Change the old secondary filter to the new primary filter
- Install new filters as secondary filters
- Dispose of the old primary filter
- Reinstall front panel and start up



The following tools are required to replace the equipment:

- 6 FT ladder
- Tape
- Marker



The following safety precautions must be followed by all personnel handling the equipment and filtration columns:

- It is recommended you follow all of your existing lab safety protocols as they apply to this procedure.
- 2 persons required for this procedure.
- Read instructions carefully before attempting.
- Do NOT have fans running during this process.

### Step 1

Turn the filtered hood completely off and disconnect the power plug. Remove the front panel (see [Section 8: Front Panel Removal](#)) of the filtered hood and place nearby but out of the way of the filtered hood. This will expose the filtration column technology you will be working with.

### Step 2

Identify the filtered hood you have and order the correct filters but in type and quantity for replacing. Determine your model number which is a M1 (3 FT), M2 (4 FT), M3 (5 FT), M4 (6 FT), or M5 (8 FT). These numbers are based on how many stacks of technology that you have on top of your filtered hood from left to right and the filtered hood width.

- Look at your filtered hood and count the stacks of technology from left to right
- You will have 1, 2, 3, 4, or 5 stacks for 3 FT, 4 FT, 5 FT, 6 FT, and 8 FT filtered hoods.
- Match that number to M1, M2, M3, M4, or M5.
- This information will help you follow this procedure when it applies to your model M1, M2, M3, M4, M5.



**All primary filters must be replaced at the same time.** See the [Section 9: Accessories](#) for ordering details. Make sure you have the new filters on hand before following the next steps.

### Step 3

To unpack the new filters, carefully remove from the packaging. The Neutrodine filters are shipped directly

**Figure 8-13**

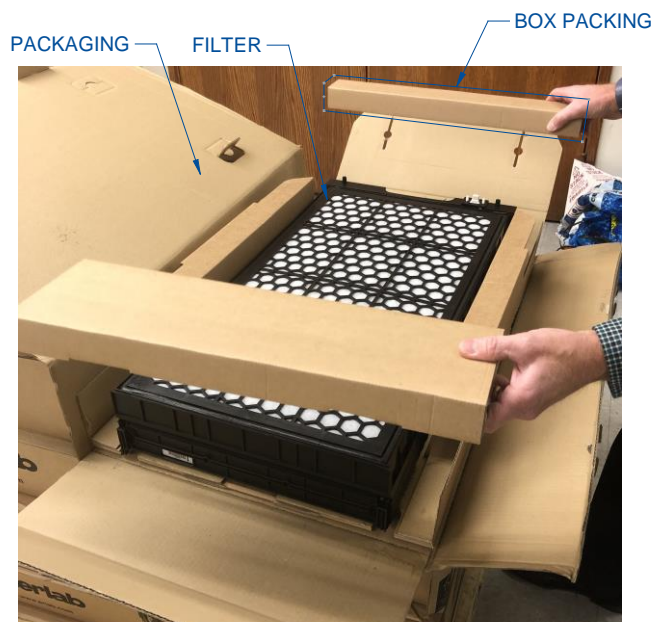

from the filter manufacturer to your job site. Remove all packing material, lay them flat and stack them out of the way of the filtered hood, but near it. Do not throw away any packaging until all filters are installed and operating correctly.

#### Step 4

Starting with filtration column 1, to access the old primary filter, the secondary filter and fan box must be removed. Once these are removed, the old primary filter is the only unit left on the base frame of the column. Mark the remaining used primary filter with a note like “Used” with the tape and marker.

The fan and secondary filters will eventually be going back on the filtration column so lay them flat and stack them out of the way.

**Figure 8-14**

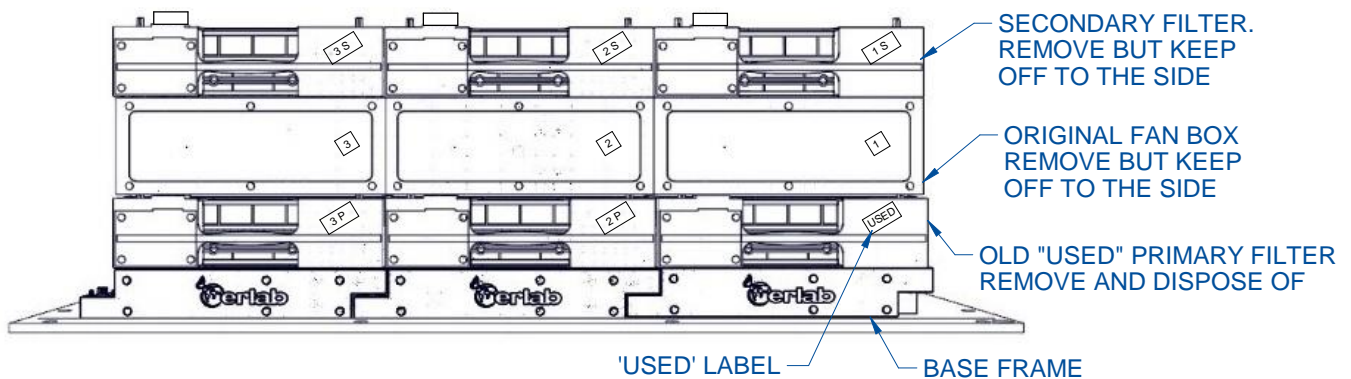

#### Step 5

Remove the old primary filter you just labeled as “used”. This filter will be disposed of. Consult local regulations and laws for disposal of hazardous waste.

#### Step 6

The old secondary filter that was removed and stacked near the substructure will now become the primary filter. Label this filter with a “P” over the existing “S” with the tape and marker (as shown in Figure 8-15) and stack back in the column it originally came from. The new label should be easy to read as the primary sticker. Remove the secondary sticker if needed to make the new label clear. To review how to install filters see [Section 4: Filtration Installation](#). Once stacked, make sure the locators are inserted firmly and the electrical connections are good.

**Figure 8-15**

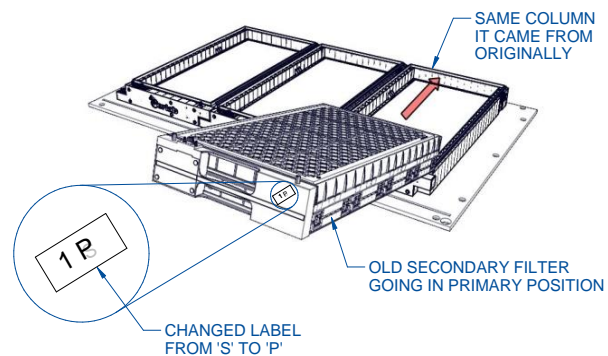

### Step 7

From here, the fan box and the new filter are stacked back on the column. Start with the fan, making sure the seal is tight and electrical connection is good. The fan (should already be labeled with column number) should match the number of the new primary filter and the column it is placed in.

Next, the new filter will be placed on top of the fan box. Once in place, label it as the secondary filter with the column number (will match the fan and primary number) and with the letter “S”.

For more detailed instructions on how to place and label filters and fan boxes see [Section 4: Filtration Installation](#).

**Figure 8-16**

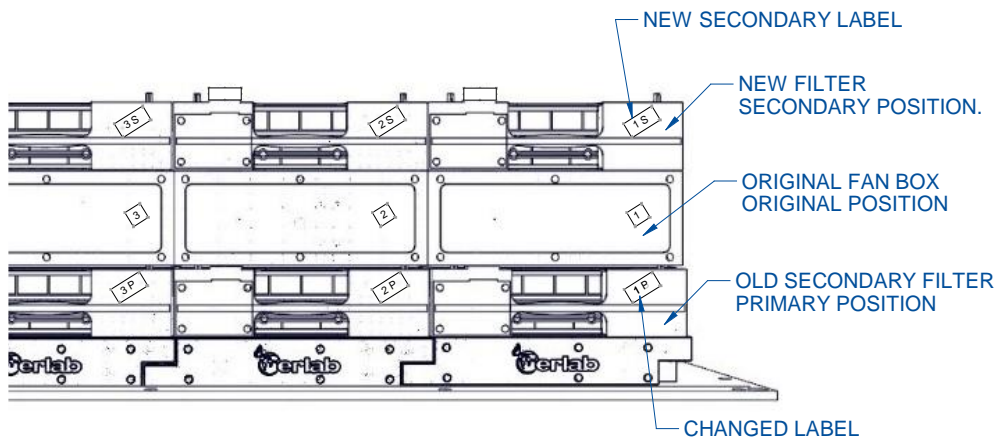

### Step 8

Repeat steps 4 through 7 for all columns. All primary filters must be replaced at once and disposed of correctly. When completed, it will look like Figure 8-16.

### Step 9

When all primary filters have been replaced, plug the filtered hood back in. Power up and check all lights, fans and filters are working properly. If the hood is in alarm, check eGuard for the explanation. If eGuard says the Primary/Secondary filter(s) have been replaced, press the **[mute]** button on the command module. If the alarm is anything other than the replaced message, disconnect the power, re-check all electrical connections and try again. Do not leave the filtered hood running while troubleshooting. When properly working, reinstall the front panel and resume using the filtered hood.

## Fan Replacement

Fans will need replacement when damaged or if failure occurs in the fan's motor or solvent sensor.

This section will cover how to:

- Remove front panel
- Identify your model and order new fans
- Unpack new fan boxes
- Access the old fan boxes
- Remove and dispose of old fan boxes
- Insert the new fan boxes
- Replace secondary filters in filtration column
- Reinstall front panel and start up



The following tools are required to replace the equipment:

- 6 FT ladder
- Tape
- Marker



The following safety precautions must be followed by all personnel handling the equipment and filtration columns:

- It is recommended you follow all of your existing lab safety protocols as they apply to this procedure.
- 2 persons required for this procedure.
- Read instructions carefully before attempting.
- Do NOT have fans running during this process.

### Step 1

Turn the filtered hood off and disconnect the power plug. Remove the front panel (see [Section 8: Front Panel Removal](#)) of the filtered hood and place nearby but out of the way of the filtered hood. This will expose the filtration column technology you will be working with.

### Step 2

Identify the filtered hood you have and order the correct quantity for replacing. Determine your model number which is a M1 (3 FT), M2 (4 FT), M3 (5 FT), M4 (6 FT), or M5 (8 FT). These numbers are based on how many stacks of technology that you have on top of your filtered hood from left to right and the filtered hood width.

- Look at your filtered hood and count the stacks of technology from left to right
- You will have 1, 2, 3, 4, or 5 stacks for 3 FT, 4 FT, 5 FT, 6 FT, and 8 FT filtered hoods.
- Match that number to M1, M2, M3, M4, or M5.
- This information will help you follow this procedure when it applies to your model M1, M2, M3, M4, M5.

### Step 3

To unpack the new fans, carefully remove from the packaging. Keep track of all boxes after unpacking. The fan boxes are shipped directly from the filter manufacturer to your job site. Once you've remove all packaging material, lay them flat and stack them out of the way of the filtered hood but near it.

### Step 4

To access the defective fan box, the secondary filter must be removed. Mark the old fan box that will be removed with a note like "Used" with the tape and marker.

### Step 5

Remove the old fan box you just labeled as "Used". This fan will be disposed of. It must be disposed of correctly. Consult local regulations and laws for disposal of hazardous waste.

### Step 6

The new fan box will now be placed on the primary filter. Make sure to stack the fan back in the column it originally came from and label it. Use the tape and a marker to label the fan box with the number of the column it is in. To review how to install the fans see [Section 4: Filter Installation](#). Make sure the seal is tight and electrical connection is verified.

**Figure 8-17**

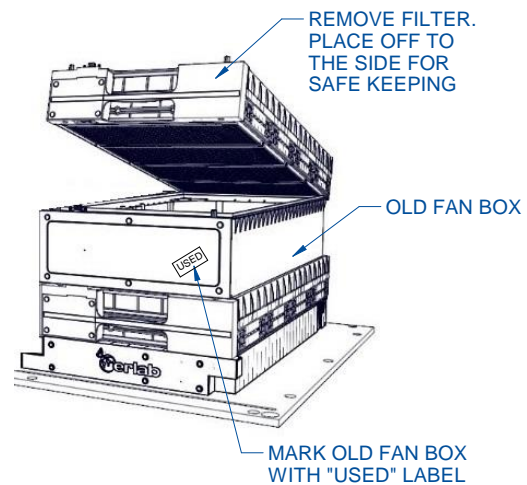

**Figure 8-18**

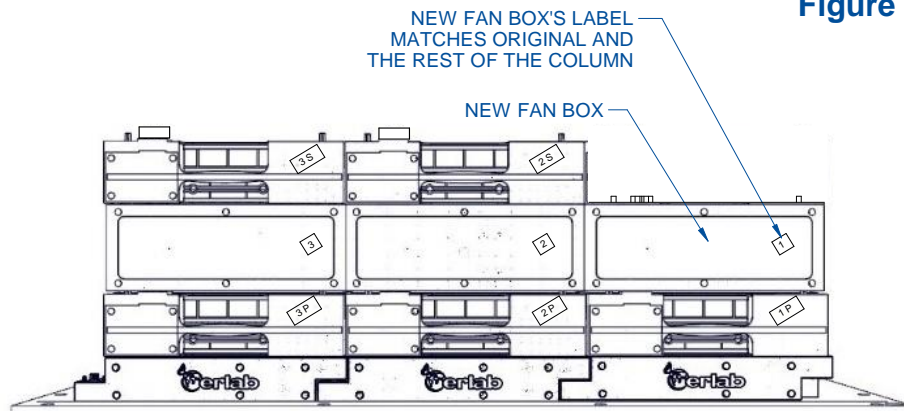

### Step 7

Next, the secondary filter must be replaced. Install above the fan box and check the seal is tight and electrical connection is verified. Make sure the label matches the column number it is in.

For more detailed instructions on how to place and label filters see [Section 4: Filter Installation](#).

### Step 8

Repeat steps 4 through 7 for all columns that need a fan box replaced. All fan boxes must be disposed of correctly. When completed, it will look like Figure 8-19.

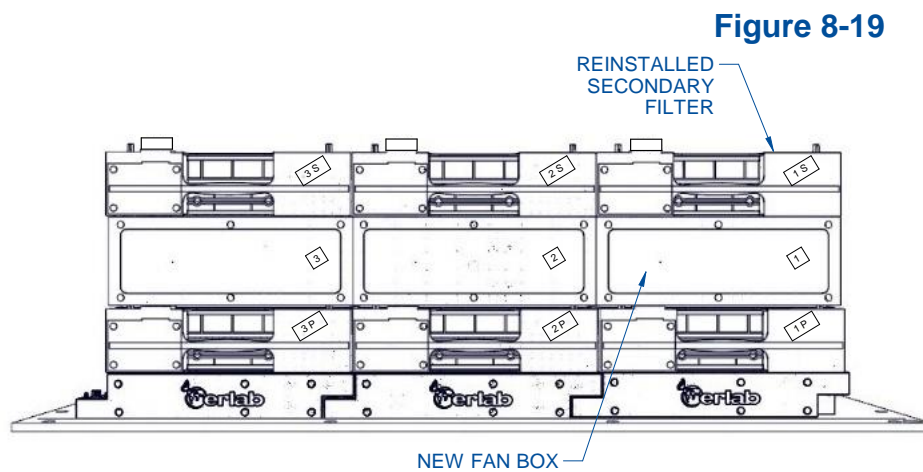

### Step 9

When all fan boxes have been replaced, connect the filtered hood to power. Power up and check all lights and fans are working properly. If the filtered hood is in alarm, check eGuard for the explanation. If eGuard says the XXX sensor or fan(s) has been replaced, press the **[mute]** button on the command module. If the alarm is anything other than a replaced message, disconnect the power, re-check all electrical connections and try again.

When properly working, reinstall the front panel and resume using the filtered hood.

### Optional HEPA Filter Installation or Replacement

While the Neutrodine filters are great for liquid chemicals and vapors, the optional HEPA filter is required for powder or particulate capture. If using HEPA filters, the fan's recommended maximum Working Setpoint will increase from 2,400 – 2,600 rpm to 2,600 – 2,800 rpm. In addition, the HEPA filters need replacing either annually or if the face velocity drops below the recommended speed (airflow alarm active with sash at operating height), whichever happens first.

The standard filtration technology column figuration discussed previously in this manual is called "2C". The "2C" configuration is built as follows (from bottom to top): base frame, primary filter, fan box and secondary filter. There are two kinds of filtration column configurations that utilize the optional HEPA filters, 1P2C and 2C1P, which will be talked about in this section.

## 1P2C

Traditional configuration for use with powders, liquids and vapors, the 1P2C column configuration positions the HEPA filter immediately above the base frame. Following the HEPA filter is the junction frame, primary filter, fan box and secondary filter on top. This order is shown in Figure 8-20.

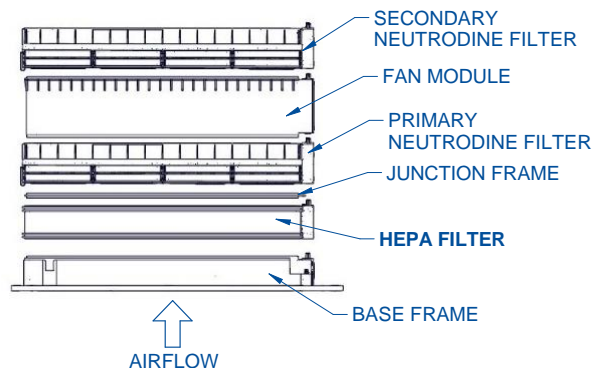

Figure 8-20

## 2C1P

Also utilized with powders, liquids and vapors, the 2C1P configuration is intended for cleanrooms. The 2C1P can be installed in cleanrooms classified from ISO 1 up to ISO 7 according to ISO 14644. The HEPA is located at the very top of the filtration column. This is shown in Figure 8-21.

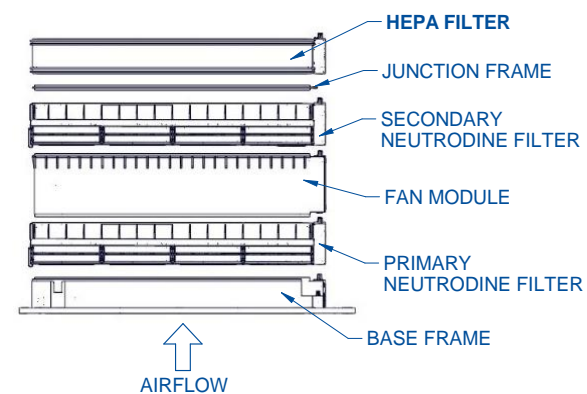

Figure 8-21



**Note:** The 1P2C configuration is preferred for dangerous particles or powders because contaminated air is always under negative pressure until passing through the HEPA filter.

## Installation and Replacement

This section will cover how to:

- Remove front panel
- Identify your model and order new HEPA filters
- Unpack new HEPA filters
- Access the old HEPA filter
- Remove and dispose of the old HEPA filter
- Insert the new HEPA filter
- Restack any previously removed technology
- Reinstall front panel and start up



The following tools are required to replace the equipment:

- 6 FT ladder
- Tape
- Marker



The following safety precautions must be followed by all personnel handling the equipment and filtration columns:

- It is recommended you follow all of your existing lab safety protocols as they apply to this procedure
- 2 persons required for this procedure
- Read instructions carefully before attempting
- Do NOT have fans running during this process

### Step 1

Turn the filtered hood completely off and disconnect from external power. Remove the front panel (see [Section 8: Front Panel Removal](#)) of the filtered hood and place nearby but out of the way. This will expose the filtration column technology you will be working with.

### Step 2

Identify the filtered hood you have and order the correct filters but in type and quantity for replacing. Determine your model number which is a M1 (3 FT), M2 (4 FT), M3 (5 FT), M4 (6 FT), or M5 (8 FT). These numbers are based on how many stacks of technology that you have on top of your filtered hood from left to right and the filtered hood width.

- Look at your filtered hood and count the stacks of technology from left to right
- You will have 1, 2, 3, 4, or 5 stacks for 3 FT, 4 FT, 5 FT, 6 FT, and 8 FT filtered hoods.
- Match that number to M1, M2, M3, M4, or M5.
- This information will help you follow this procedure when it applies to your model M1, M2, M3, M4, M5.

### Step 3

To unpack the new filters, carefully remove from the packaging. The HEPA filters are shipped directly from the filter manufacturer to your job site. Remove all packing material, lay them flat and stack them out of the way of the filtered hood, but near it. Do not throw away any packaging until all HEPA filters are installed and operating correctly.

### Step 4

If installing the HEPAs for the first time ignore this step.

Identify the technology configuration of your filtered hood as either 1P2C or 2C1P. See Figure 8-20 & 8-21 for help identifying the configuration of the filtered hood.

- If a 2C1P model, no other filtration technology must be removed. The top unit on the column is the HEPA filter, label it “Used”.
- If a 1P2C model, remove the secondary filter, fan box and primary filter to access the HEPA. Stack them carefully. Label the HEPA filter “Used”.

### Step 5

If you are installing the HEPA filters for the first time, ignore this and move to the next step.

Remove the old HEPA filters you just labeled as “Used”. This filter will no longer be in use so it must be disposed of correctly. Consult local regulations and laws for disposal of hazardous waste. Do NOT dispose of the junction frame shown in Figure 8-20 & 8-21. The frame will be used again later.

### Step 6

The new HEPA filters will now be placed in the column.

If a 2C1P model:

1. Place the junction frame on top of the secondary filter. See Figure 8-21.
2. Then lower the HEPA filter on the frame.
3. Verify the connection is secure and all sides are sealed.

If a 1P2C model:

1. Lower the HEPA filter on the base frame.
2. Place the junction frame on the top of the HEPA filter.
3. Verify the connection is secure and all sides are sealed.

If replacing, make sure to stack the filters and fan boxes in the column they originally came from. Use the tape and a marker to label the HEPA filter with the number of the column it is in.



**Note:** The junction frame always goes between the HEPA and a Neutrodine filter in 2C1P and 1P2C models for containment safety.

### Step 7

If making the 2C1P configuration, place cap on the HEPA filter’s electrical plug and move to the next step.

If making the 1P2C configuration, locate the Neutrodine filters and fan box previously removed from the column. Replace them in the following order bottom to top (shown in Figure 8-20):

1. Junction frame
2. Primary filter
3. Fan box
4. Secondary filter

Ensure the filters and fan boxes are all in the correct column and that the primary filter is

**Figure 8-22**

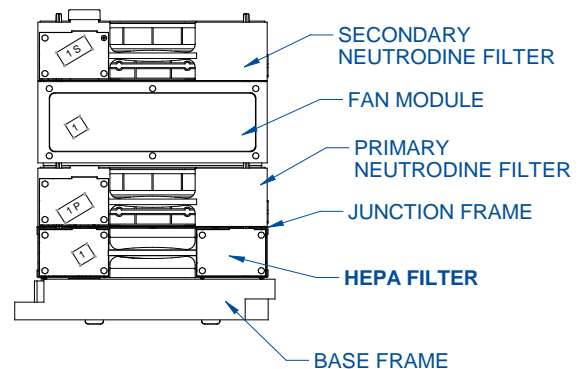

closest to the HEPA. Also check the seal is tight and electrical connection is good. Make sure the secondary filter is the top most layer of the column.

### Step 8

Repeat for all columns that need new or replaced HEPA filters.

### Step 9

When all filters and fan boxes have been replaced, reconnect the filtered hood to power. Power up and verify all lights and fans are working properly. If the filtered hood is in alarm, check eGuard for the explanation. If eGuard says the HEPA filter(s) has been replaced, press the **[mute]** button on the command module. If the alarm is anything other than a replaced message, disconnect the power, re-check all electrical connections and try again. Do not leave running while troubleshooting. When properly working, reinstall the front panel and resume using the filtered hood.

### Airflow Sensor Replacement

The anemometer or airflow sensor (AFS) is found on the left wall of the filtered hood. When no longer operating correctly, it will need to be replaced. If removal of the left side panel (or right on 3 FT 31.7-inch depth Protector® Airo™) is not possible due to lack of clearance, see Appendix H: Low Clearance AFS Removal. This section will cover:

- Order and unpack new sensor
- Access the old sensor
- Remove the old sensor
- Insert the new sensor
- Enclose the new sensor
- Recalibrate the filtered hood



The following tools are required to replace the equipment:

- Phillips screwdriver
- 5/16-inch nut driver
- Possibly a flashlight
- Recommended to have a second person

### Step 1

Order a new sensor, see [Appendix A: Parts List](#) for information on part numbers. The sensor is shipped directly from the filter manufacturer to your job site. Unpack neatly and keep the cartoning until the new sensor is operating properly.

### Step 2

To access the sensor, the left side panel must be removed (if changing on the 3 FT 31.7-inch depth Protector® Airo™, the right panel must be removed).

Figure 8-23

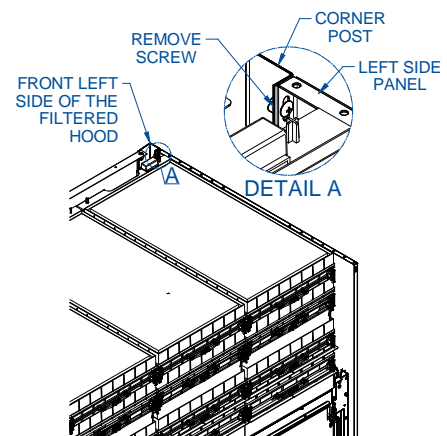

Locate the screw on the top, front edge of the panel as shown in Figure 8-23. Remove and save this hardware for later. Lift the left side panel approximately 3 inches up to clear the structures holding it in place and pull straight away from the filtered hood until free of the filtered hood. Store away from the filtered hood and keep track of this panel.

Figure 8-24

### Step 3

Once exposed, locate the hardware holding the sensor in place. First, unplug the sensor from the power supply cable and let the cable hang. If possible, use a second person to hold the white capped head of each screw from inside the filtered hood and remove the four nuts with a nut driver. Remove the sensor from the screw studs. Save all hardware.

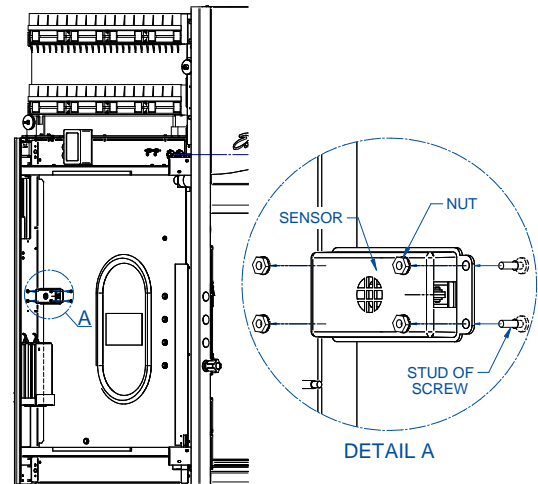

### Step 4

Reverse step 3. Place the new sensor on the studs identified in Figure 8-24. Using the nut driver, secure the four nuts holding the sensor in place. Hold the capped screw heads from inside the filtered hood if needed. Once the new sensor is firmly in place, plug the cable from the power supply into the sensor port.

### Step 5

Power up the filtered hood. If in alarm, check eGuard for the explanation. If eGuard says the sensor has been replaced, press the **[mute]** button on the command module. If the alarm is anything other than a replaced message, disconnect the power, re-check all electrical connections and try again.

When properly working, reinstall the side panel back on the filtered hood, and reapply the screw removed.

### Step 6

Recalibrate the anemometer by following the steps in [Section 4: Calibrating the airflow sensor](#). Once this is complete, the filtered hood should be working properly.

### Solvent, Acid & Formaldehyde Sensor Replacement

The acid and the formaldehyde sensors are replaced in the exact same way. They should be replaced when you are alerted in eGuard its time or after 2 years. This section will cover how to:

- Remove the old sensor
- Install the new sensor
- Recalibrate the filtered hood



The following tools are required to replace the equipment:

- Flathead screwdriver
- T10 Torx screwdriver

### Step 1

Order and unpack the new sensor. Orderable parts can be found in [Appendix A: Parts List](#). Locate the fan box in the filtered hood with the 'A' or 'F' sticker as shown in [Figure 8-25](#). This is the old sensor; label it as 'Used'. If installing the sensor for the first time, reference [Appendix G: Acid/Formaldehyde Sensor Locations](#) for placement instructions.

### Step 2

Use the flathead screw driver to remove the 6 screw caps. Wedge underneath and pop out to expose screws. Save the caps.

Use the torx screw driver to remove the 6 screws shown in [Figure 8-25](#) that keep the fan box's front panel in place. Save the screws.

### Step 3

Carefully pull the 'Used' front panel away from the body of the fan box. Dispose of the used sensor.

### Step 4

Install the new sensor front panel onto the fan box. Ensure a proper connection of the female to male plug in the front of the fan box shown in [Figure 8-26](#). Label the fan box with the column number it is located in (the same number the 'Used' sensor had).

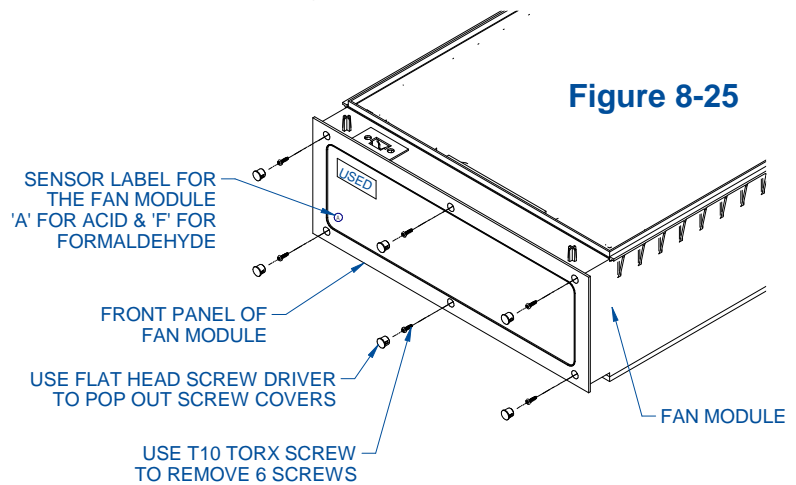
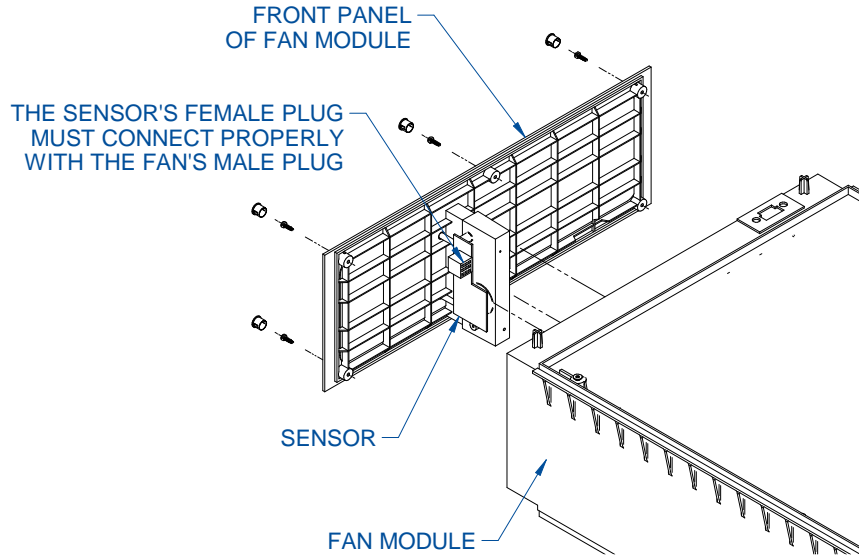

Figure 8-26



#### Step 5

Start up the filtered hood. If the filtered hood is in alarm, check eGuard for the explanation. If eGuard says the base frame has been replaced, press the **[mute]** button on the command module. If there is an alarm other than the replacement message, disconnect the power, re-check all electrical connections and try again.

When properly working, reinstall the torx screws and screw caps and resume using the filtered hood.

#### Step 6 (if needed)

Recalibrate the filtered hood by following the steps in [Section 4: Calibrating the airflow sensor](#).

## 9: Accessories

This section details the available field-installable accessories and approved modifications for the filtered hood. These include the addition of replacement Neutrodine carbon filters, HEPA filters, work surfaces, base stands, base stand shelves, seismic supports, storage cabinets, service fixtures, electrical duplex outlets, sash stops, distillation grids and sash reduction wing kits.

### Filters

Table 9-1

Catalog # (10/2020 to 1/2025)	Catalog # (2/2025 to Current)	Description
9577420	9577460	Neutrodine molecular carbon filter (universal)
9577421	9577461	Optional HEPA filter
9577422	9577422	Pre-filter, located in Base Frame, Standard
9577423	9577423	Pre-filter, located in Base Frame, Optional: Inorganic Acids
9577424	9577424	Pre-filter, located in Base Frame, Optional: Ammonia

The filtered hood model sizes, filter compartments, and number of filters are listed below for installation convenience.

Table 9-2

Hood Size	Filter Columns	Required No. of Neutrodine Filters	Total Neutrodine Filter Weight	Optional No. of HEPA Filters	Total HEPA Filter Weight
3 FT	1	2	50 lbs.	1	10 lbs.
4 FT	2	4	100 lbs.	2	20 lbs.
5 FT	3	6	150 lbs.	3	30 lbs.
6 FT	4	8	200 lbs.	4	40 lbs.
8 FT	5	10	250 lbs.	5	50 lbs.

### Work Surfaces

A required work surface is available to support the filtered hood. The black epoxy work surfaces are contoured to fit the dimensions of the filtered hood to contain spills. May be

ordered with a pre-cut 6-inch x 3-inch oval cupsink cutout. Use this key to configure the **seven digit catalog number** to order a SpillStopper Dished Solid Epoxy Work Surface. For example, a **9501610** is a 6 FT wide x 36-inch deep SpillStopper Work Surface, with a left rear cupsink cutout.

**Figure 9-1**

9
5
0
1

**STEP 1.** Select the **nominal width** of your filtered fume hood. This number is the fifth digit of your catalog number. Shipping weight is noted for each width.

<p><b>4</b> = 4'</p> <p>120 lbs. (54 kg)</p> <p><b>5</b> = 5'</p> <p>160 lbs. (73 kg)</p> <p><b>3</b> = 3'</p> <p>90 lbs. (41 kg)</p>	<p><b>6</b> = 6'</p> <p>220 lbs. (100 kg)</p> <p><b>8</b> = 8'</p> <p>250 lbs. (113 kg)</p>
---	---

**1** = 36", used on all 37.7" deep Echo /Airo

**0** = 30", used on 3' x 31.7" deep Airo only

**STEP 3.** Select a **left cupsink cutout** option (cupsink is sold separately). See dimensional drawing. This number is the sixth digit of your catalog number.

Left Cupsink Cutout	
<b>0</b>	None
<b>1</b>	Rear
<b>2</b>	Side*

**STEP 4.** Select a **right cupsink cutout** option (cupsink is sold separately). See dimensional drawing. This number is the seventh digit of your catalog number.

Right Cupsink Cutout	
<b>0</b>	None
<b>1</b>	Rear
<b>2</b>	Side*

\*Not compatible with Protector Solvent Storage Cabinets.

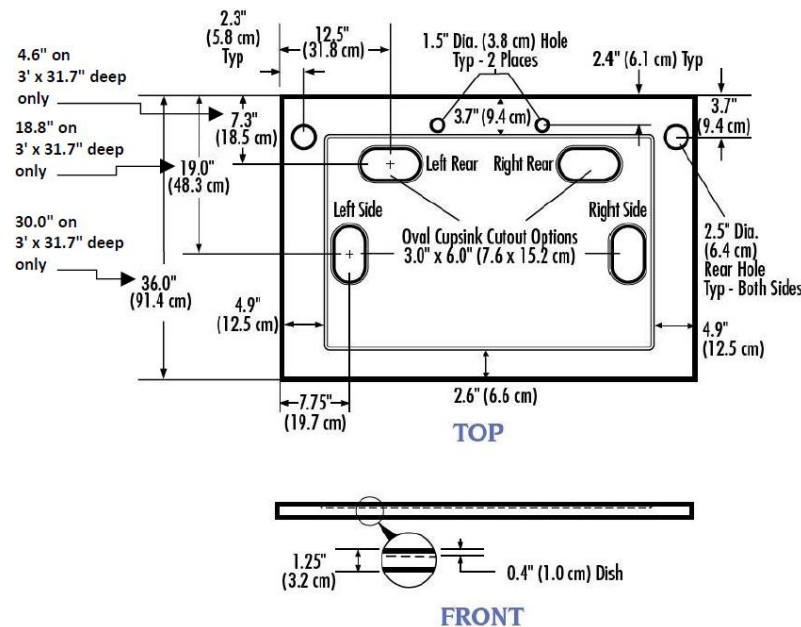

**4005200 Oval Polypropylene Cupsink**  
Mounts in work surface with cupsink cutout, 3.0" x 6.0" (7.6 x 15.2 cm). 1.5" (5.8 cm) National Pipe Straight Mechanical (NPSM) thread. Shipping weight 4 lbs. (2 kg)

## Base Stands, Accessory Shelves, Seismic Supports, and Hydraulic Lift Base Stands

The following base stands, hydraulic lift base stands, accessory shelves, and seismic supports may be used with the accessory work surfaces to support the filtered hoods. Hydraulic Lift Base Stands allow easy movement up and down and may be portable if the caster kit is also ordered.

**Table 9-3**

Catalog #	Description	Size (if applicable)
3746701	3' Base Stand w/Feet	3' x 29" x 27.35"-33.5"
3746702	4' Base Stand w/Feet	4' x 29" x 27.35"-33.5"
3746703	5' Base Stand w/Feet	5' x 29" x 27.35"-33.5"
3746704	6' Base Stand w/Feet	6' x 29" x 27.35"-33.5"
3746711	3' Base Stand w/Casters	3' x 29" x 27.35"-33.5"
3746712	4' Base Stand w/Casters	4' x 29" x 27.35"-33.5"
3746713	5' Base Stand w/Casters	5' x 29" x 27.35"-33.5"
3746714	6' Base Stand w/Casters	6' x 29" x 27.35"-33.5"
3811101	3' Shelf, Base Stand	25.4" x 32.4"
3811102	4' Shelf, Base Stand	25.4" x 44.4"
3811103	5' Shelf, Base Stand	25.4" x 56.4"
3811104	6' Shelf, Base Stand	25.4" x 68.4"
3857000	Seismic Support Bracket Kit	N/A
3780310	Portable 3' SoLo Hydraulic Lift Base Stand, 115 V	53.5" x 34.3" x 17.2"-36.8"
3780314	Portable 3' SoLo Hydraulic Lift Base Stand, 230 V	53.5" x 34.3" x 17.2"-36.8"
3780311	Portable 4' SoLo Hydraulic Lift Base Stand, 115 V	65.5" x 34.3" x 17.2"-36.8"
3780315	Portable 4' SoLo Hydraulic Lift Base Stand, 230 V	65.5" x 34.3" x 17.2"-36.8"
3780312	Portable 5' SoLo Hydraulic Lift Base Stand, 115 V	77.5" x 34.3" x 17.2"-36.8"
3780316	Portable 5' SoLo Hydraulic Lift Base Stand, 230 V	77.5" x 34.3" x 17.2"-36.8"
3780313	Portable 6' SoLo Hydraulic Lift Base Stand, 115 V	89.5" x 34.3" x 17.2"-36.8"
3780317	Portable 6' SoLo Hydraulic Lift Base Stand, 230 V	89.5" x 34.3" x 17.2"-36.8"
3780300	3' Electrical Hydraulic Lift Base Stand, 115V	36.0"W x 29.0" Dp
3780303	3' Electrical Hydraulic Lift Base Stand, 230V	36.0"W x 29.0" Dp
3780301	4' Electrical Hydraulic Lift Base Stand, 115V	48.0"W x 29.0" Dp
3780304	4' Electrical Hydraulic Lift Base Stand, 230V	48.0"W x 29.0" Dp
3780306	5' Electrical Hydraulic Lift Base Stand, 115V	60.0"W x 29.0" Dp
3780307	5' Electrical Hydraulic Lift Base Stand, 230V	60.0"W x 29.0" Dp
3780302	6' Electrical Hydraulic Lift Base Stand, 115V	72.0"W x 29.0" Dp
3780305	6' Electrical Hydraulic Lift Base Stand, 230V	72.0"W x 29.0" Dp
3780400	3' Manual Hydraulic Lift Base Stand	36.0"W x 29.0" Dp
3780401	4' Manual Hydraulic Lift Base Stand	48.0"W x 29.0" Dp
3780403	5' Manual Hydraulic Lift Base Stand	60.0"W x 29.0" Dp
3780402	6' Manual Hydraulic Lift Base Stand	72.0"W x 29.0" Dp
3784000	Portable Caster Kit for Electric and Manual Hydraulic Lift Base Stands	N/A

## Storage Cabinets

The following storage cabinets may be used with the accessory work surfaces to support the filtered hoods.

**Table 9-4**

Size/Description	SOLVENT			ACID		
	Dual Doors	Right Hinge	Left Hinge	Dual Doors	Right Hinge	Left Hinge
48"	9902000	-	-	9901000	-	-
36"	9902100	-	-	9901100	-	-
30"	9902200	-	-	9901200	-	-
24"	-	9902300	9902400	-	9901300	9901500
18"	-	-	-	-	9901400	9901600
48" w/Self-Closing Doors	9903000	-	-	-	-	-
36" w/Self-Closing Doors	9903100	-	-	-	-	-
30" w/Self-Closing Doors	9903200	-	-	-	-	-
24" w/Self-Closing Doors	-	9903300	9903400	-	-	-
24" ADA	-	9906000	9906100	-	9905000	9905200
24" ADA w/Self-Closing Doors	-	9906200	9906300	-	-	-
18" ADA	-	-	-	-	9905100	9905300

**Table 9-5**

Size/Description	STANDARD BASE			VACUUM PUMP		
	Dual Doors	Right Hinge	Left Hinge	Dual Doors	Right Hinge	Left Hinge
48"	9900000	-	-	-	-	-
36"	9900100	-	-	-	-	-
30"	9900200	-	-	-	-	-
24"	-	9900300	9900600	-	-	-
18"	-	9900400	9900700	-	9907000	9907100
12"	-	9900500	9900800	-	-	-

## Installing Additional Service Fixtures

Additional service fixtures can be installed in the available service fixture holes in both sidewalls and corner posts. The filtered hood is factory set to accept up to four valves per side.

### Standard Service Fixture Kits

For mounting on the left or right side of any filtered hood. Each kit includes one remotely-controlled service fixture with valve and ¼-inch O.D. tubing, color-coded fixture knob and color-coded hose connector.\* **Inlet tubing is not included.** Shipping weight 4 lbs. (2 kg)

**Figure 9-2**

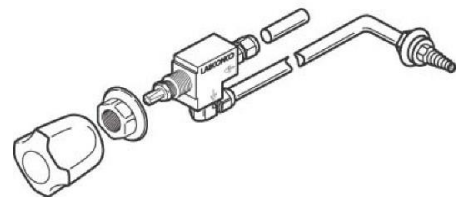

**Table 9-6**

Catalog #	Kit	Tubing	Valve	Knob/Connector Color	Max. Flow Rate	Max. Working Pressure
9808300**	Cold Water (CW)	Copper	Brass	Green	3.5 GPM (13.2 LPM)	40 psi
9808400**	Air (AIR)	Copper	Brass	Orange	23.7 CFM	40 psi
9808500**	Vacuum (VAC)	Copper	Brass	Yellow	8.6 CFM	14.7 psi
9808700**	Gas (GAS)	Brass	Brass	Blue	29.0 CFM (441 BTU/sec)	40 psi
9808800**	Argon (ARG)	Copper	Brass	Gray	20.2 CFM	40 psi
9808900**	Hot Water (HW)	Copper	Brass	Red	3.5 GPM (13.2 LPM)	40 psi
9809100**	Deionized/Distilled Water (DI)	Stainless Steel	Nickel-Plated & Stainless Steel	White	3.5 GPM (13.2 LPM)	40 psi
9809200**	Steam (STM)	Copper	Brass	Black	0.5 LBM/min	40 psi
9809300**	Nitrogen (NIT)	Copper	Brass	Brown	24.1 CFM	40 psi
9809700**††	Oxygen (OXY)	Copper	Brass w/ Oxygen-Compatible Lubricant	Light Green	22.6 CFM	40 psi

**Figure 9-3**

**Cold Water Gooseneck Fixture Kits**

For mounting on the left or right side of any filtered hood. Each kit includes one remotely-controlled gooseneck with brass valve and 3/8-inch O.D. copper tubing and green fixture knob. **Inlet tubing is not included.** Shipping Weight 10 lbs. (5 kg)

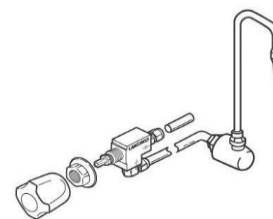

**Table 9-7**

Catalog #	Kit	Description	Max. Flow Rate	Max. Working Pressure
9827900**	Cold Water (CW) Gooseneck	For Hood with interior Depths less than 37.7". Includes green epoxy-coated brass/rigid gooseneck	3.5 GPM (13.2 LPM)	40 psi
9857700†††	Cold Water (CW) Gooseneck	For Hood with interior Depths less than 37.7". Includes gray PVC rigid gooseneck	3.5 GPM (13.2 LPM)	40 psi

**Figure 9-4**

**Hot and Cold Water Mixing Gooseneck Fixture Kit**

Each kit for any filtered hood includes one remotely-controlled, white epoxy-coated, brass rigid/swivel gooseneck with brass valve and 1/4-inch O.D. copper tubing, one green fixture knob and one red fixture knob. **Inlet tubing is not included.** Shipping weight 11 lbs. (5 kg)

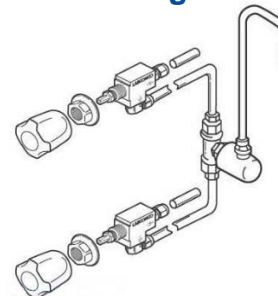

**Table 9-8**

Catalog #	Kit	Description	Max. Flow Rate	Max. Working Pressure
9828000†††	Hot (HW) and Cold Water (CW) Mixing Gooseneck	For Hoods with Interior Depths of 24" to 37.7"	3.5 GPM (13.2 LPM)	40 psi

### Deionized/Distilled Water Gooseneck Fixture Kit

For mounting on the left or right side of any filtered hood. Each kit includes one remotely-controlled, gray PVC rigid gooseneck with stainless steel valve and ¼-inch O.D. tubing and white fixture knob.

**Inlet tubing is not included.** Shipping weight 10 lbs. (5 kg)

**Figure 9-5**

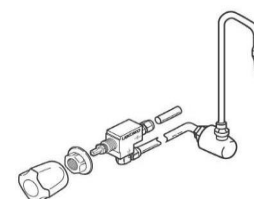

**Table 9-9**

Catalog #	Kit	Description	Max. Flow Rate	Max. Working Pressure
9853400†††	Deionized/Distilled Water (DW) Gooseneck	For Hoods with Interior Depths less than 37.7"	3.5 GPM (13.2 LPM)	40 psi

GPM = gallons per minute, LPM = liters per minute, CFM = cubic feet per minute, BTU/sec = British thermal unit per second, LBM/min = pounds mass per minute,

\*Contact Labconco for ordering information on Standard Service Features with chrome-plated brass hose connectors for protector Stainless Steel Hoods,

†Maximum allowable pressure is 200 psi with a working pressure of 40 psi,

\*\* Protector Stainless Steel and PVC Hoods require drill hole in liner,

†† WaterSaver is registered trademark of WaterSaver Company.,

††† Requires 1.375" dia. drill hole in liner.

## Installing an Electrical Duplex Outlet

Your filtered hood can be ordered with duplex outlets, however, if you ordered a model without an electrical duplex outlet you can have one installed in the field by a qualified electrician.

### Electrical Receptacle Kits

For mounting in left or right side of any 3 FT, 4 FT, 5 FT, 6 FT or 8 FT filtered hood. Each Receptacle Kit includes an electrical receptacle, wiring, junction box and receptacle cover plate. The international GFCI Switch is mountable in one corner post location above or below any international single outlet.

**Table 9-10**

Catalog #	Kits	Outlet Type	Shipping Wt.	
			lbs	kg
9851100	115 volts, 20 amps AC, 60 Hz	Duplex, U.S.	4	2
9851500	115 volts, 20 amps AC, GFCI 60 Hz	Duplex, U.S.	4	2
9854200	230 volts, 20 amps AC, 60 Hz	Duplex, U.S.	4	2
9412500	230 volts, 13 amps AC, 50 Hz	Single, British (UK)	4	2
9412700	230 volts, 16 amps AC, 50 Hz	Single, Schuko	4	2
9412900	230 volts, 10 amps AC, 50 Hz	Single, China	4	2
9413100	230 volts, 10 amps AC, 50 Hz	Single, Australia	4	2
9413900	230 volts, 6-16 amps AC, 50 Hz	Single, India-South Africa	4	2
9414100	International GFCI Switch, 16 amps	Not Applicable	4	2



**Note:** If needed, the individual duplexes can be converted for instant attachment to a wall outlet by a qualified electrician by ordering an electrical outlet as harness listed below:

**Table 9-11**

Catalog #	Description
9582710	Electrical Outlet Harness, 115V – 15A US Plug 5-15P
9582712	Electrical Outlet Harness, 115V – 20A US Plug 5-20P
9582720	Electrical Outlet Harness, 230V – 15A US Plug 6-15P

### Sash Stop Kit

The sash stop kit restricts how far a vertical-rising sash may be opened. This small plastic device may be easily field installed on the fixture corner post of any filtered hood.

**Table 9-13**

Catalog #	Description
9410300	Sash Stop Kit Left Side (included)
9410303	Sash Stop Kit Right Side

### Distillation Grid Kits

The distillation grids allow the hood user to mount glassware, motors, stirrers and other apparatus. They are for Benchtop Echos only. For orderable Floor-Mounted Distillation Grids contact Labconco.

Kits include stainless steel rods, connectors, instruction sheet and drill template. **Requires installation including drill holes.**

**Figure 9-7**

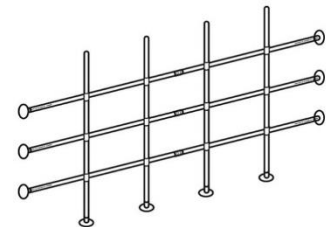

**Table 9-14**

Catalog #	Description
9725204	4 FT
9725205	5 FT
9725206	6 FT
9725200	8 FT

### Sash Reduction Wing Kits

The Sash Reduction Wing Kits are hinged with detents to maintain open and closed positions. Open position is used for loading equipment and closed position is used for normal operation. An optional accessory airflow monitor is available for sash position alarms. Alternatively, to ordering the Sash Reduction Wing Kits, the end user can simply lower the 16-inch sash stop to the 10-inch sash stop position. Sash Reduction Wing Kits promote comfort for some users that prefer a 16-inch sash opening rather than a 10-inch sash opening. To increase the sash stop height for a 6 FT Floor-mounted Echo, the wing kits can be added.

**Table 9-15**

<b>Catalog #</b>	<b>Description</b>	<b>Sash Opening</b>	<b>Sash Wing Width</b>
9584904	4 FT Sash Reduction Wing Kit	18" W X 16" H	10"
9584905	5 FT Sash Reduction Wing Kit	26" W X 16" H	12"
9584906	6 FT Sash Reduction Wing Kit	34" W X 16" H	14"
9584908	8 FT Sash Reduction Wing Kit	48" W X 16" H	19"

## 10: Troubleshooting

---

This section details common troubleshooting for the filtered hood.

### Service valves no longer operate

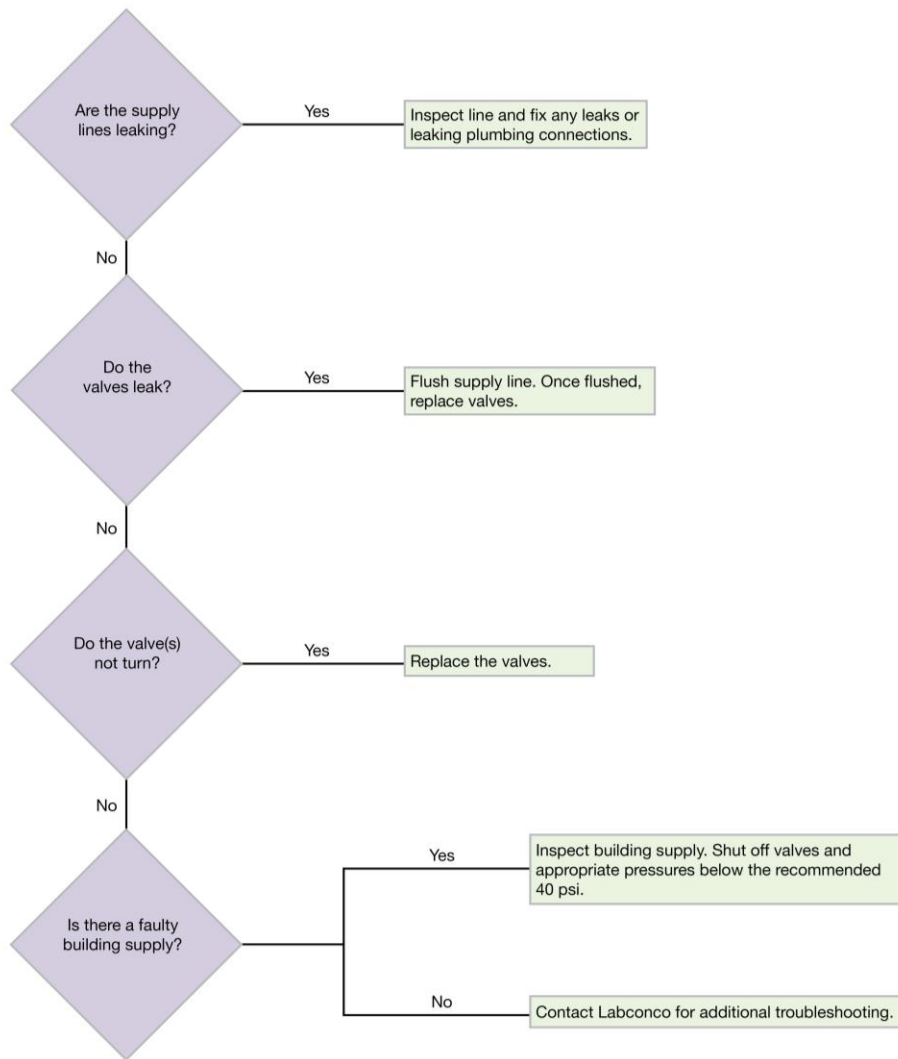

## Fans and Lights not working

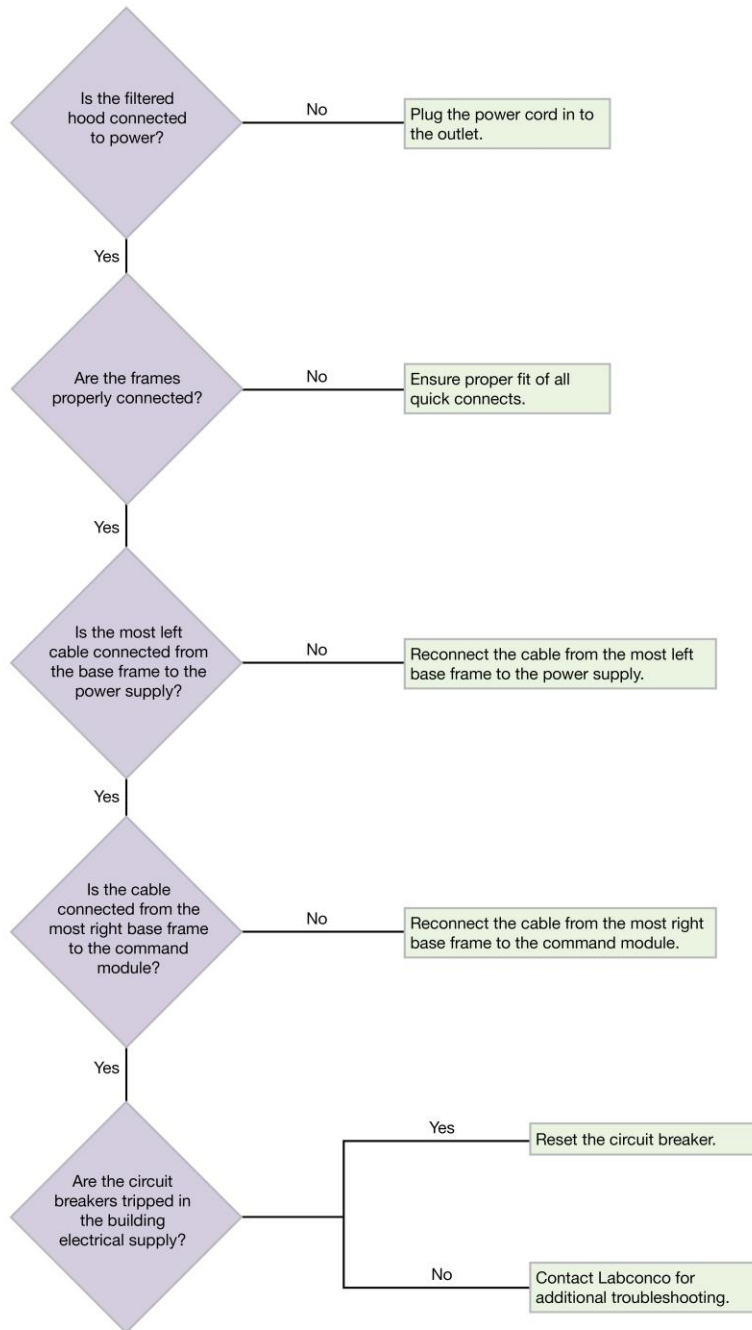

# Vertical sash no longer operates smoothly

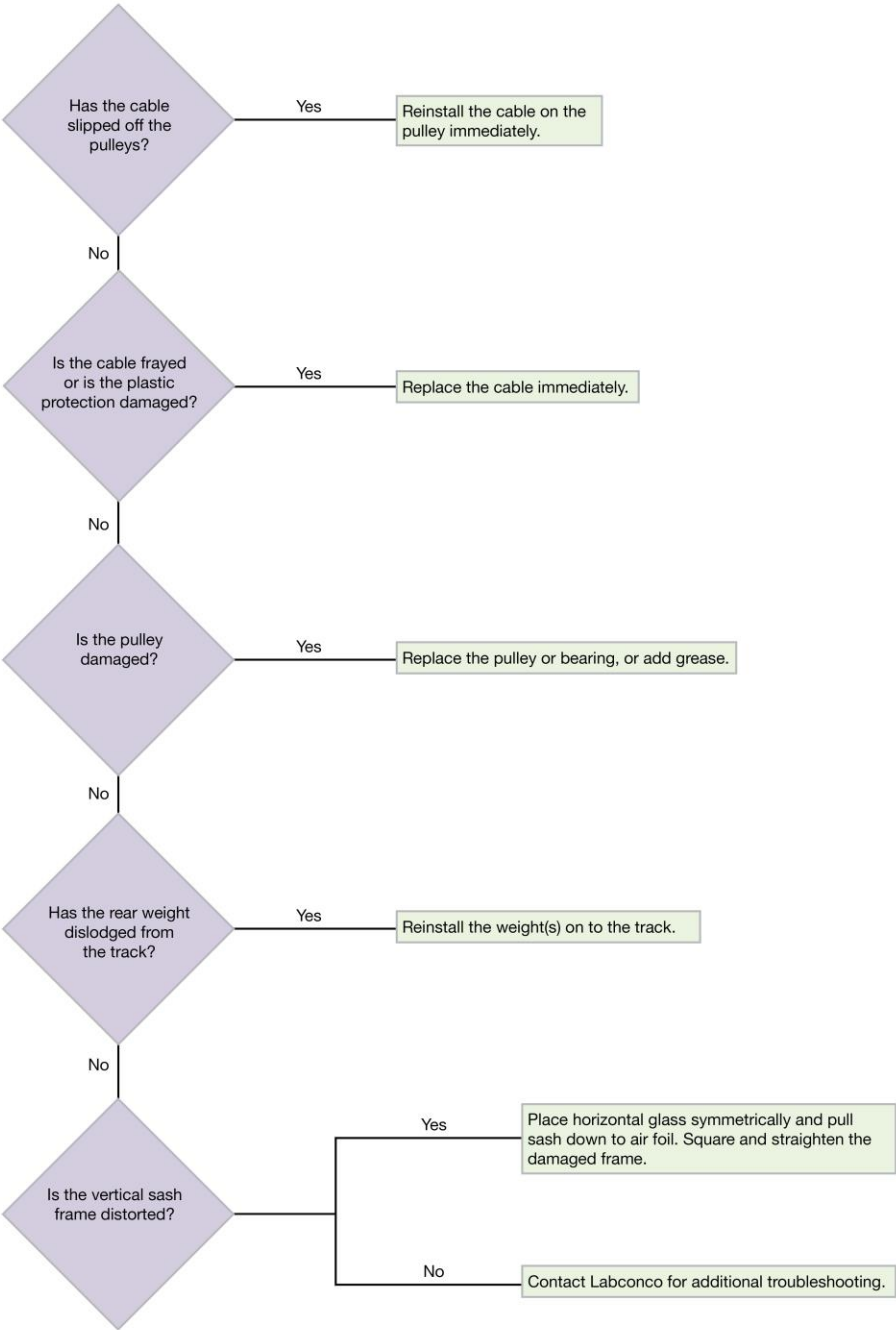

## Electrical duplex outlets no longer have power

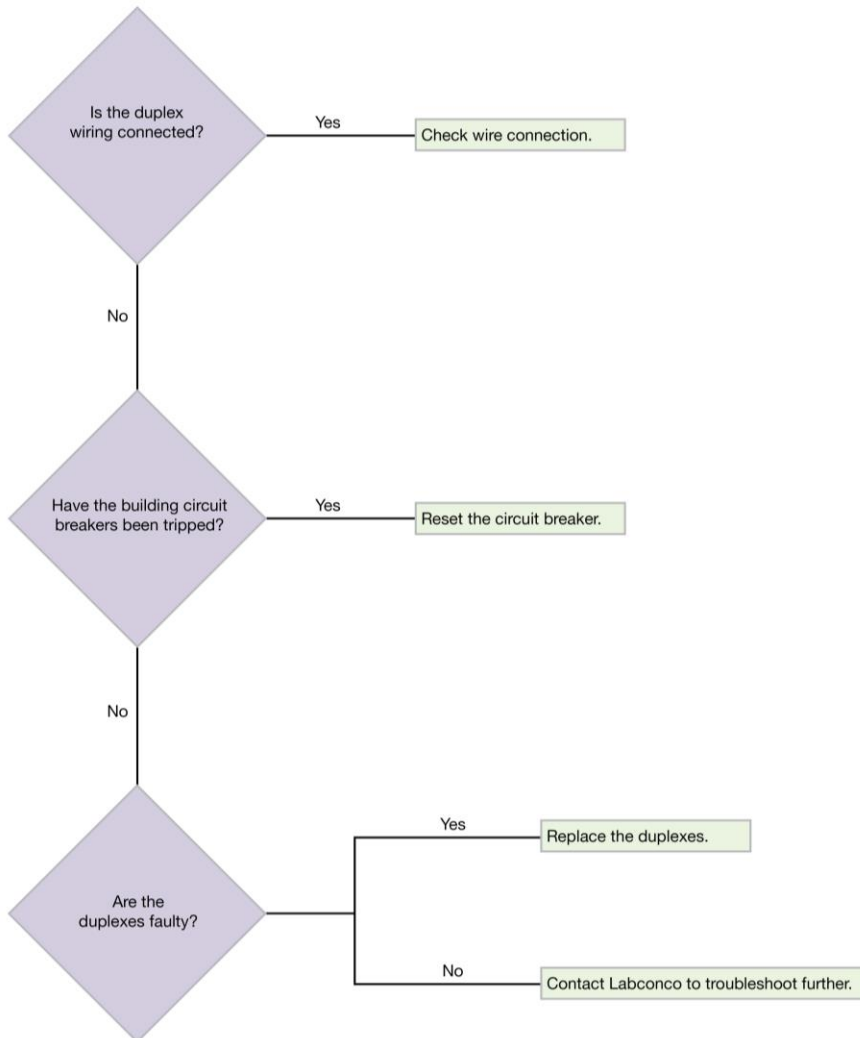

## Fan operates but lights dim or not working

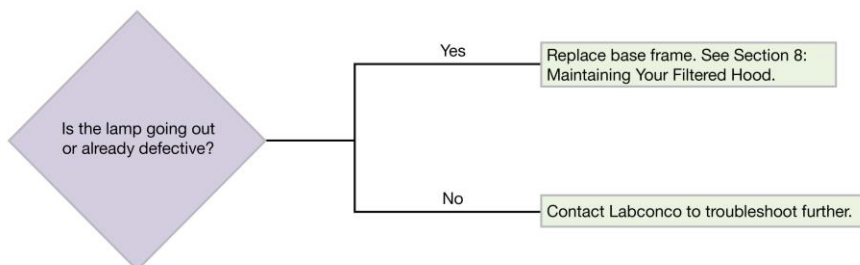



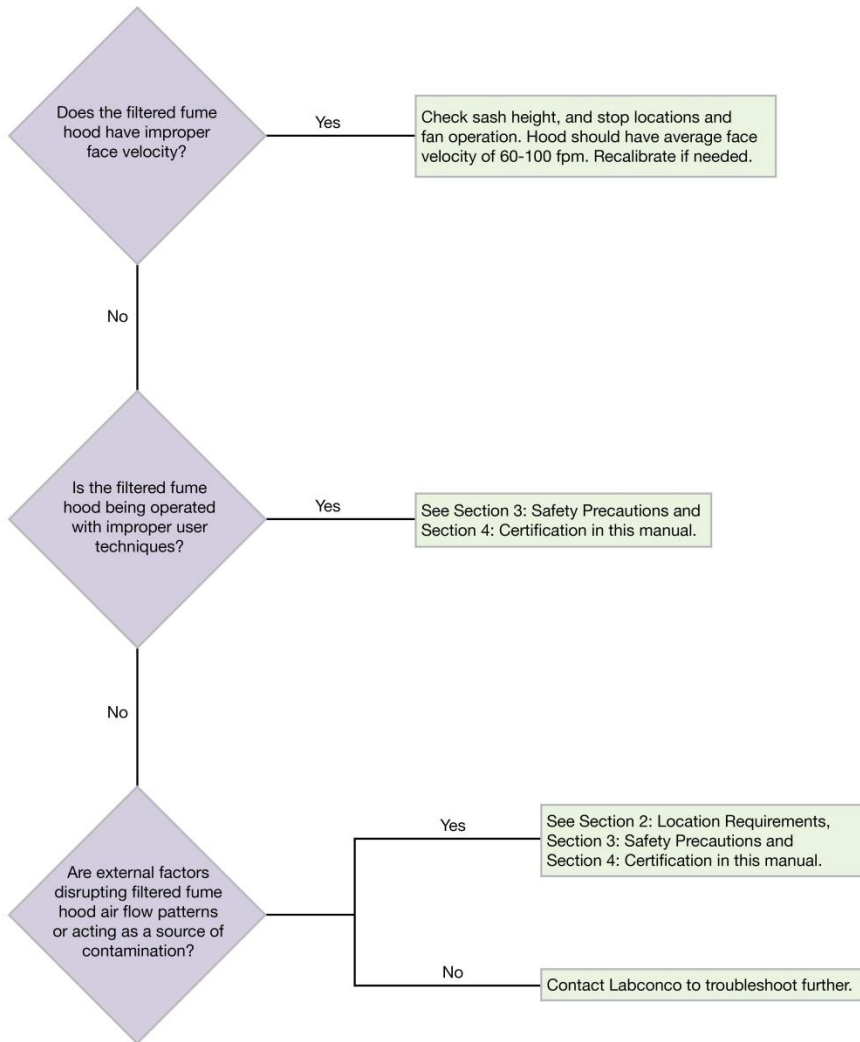

## Contaminates outside the filtered hood

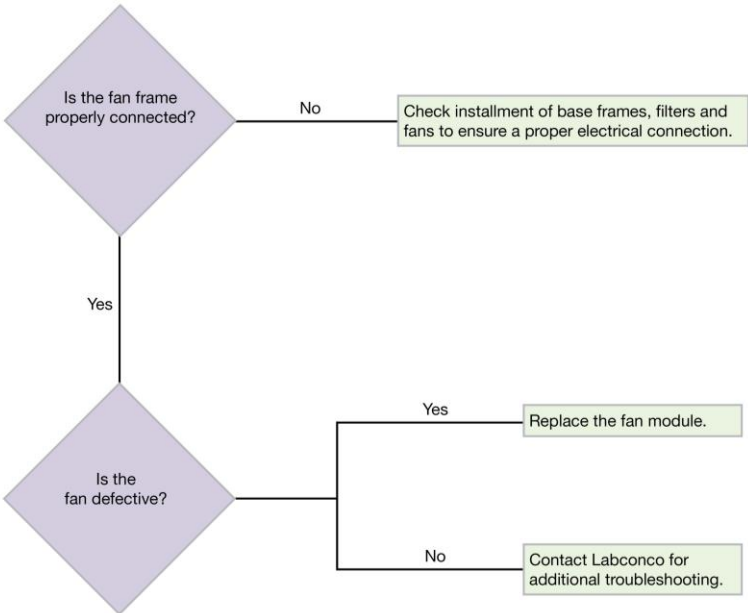

# Lights operate but fans will not



## Smart Command Alarms

Alarm	Error Message	Corrective Action(s)
<b>Face Velocity</b> 	Low face velocity	Lower the sash height to working height or lower. Recalibrate airflow sensor or raise blower RPM.
	Anemometer out of order	Recalibrate airflow sensor. Replace airflow sensor.
<b>Filter Replacement</b> 	VOC detected: replace primary filter(s)	Replace the primary filter with the secondary filter and put a new filter in the secondary position.
	Acid detected: replace primary filter(s) now	Do not use the hood until you have replaced the primary filter with the secondary filter and put a new filter in the secondary position.
	Formaldehyde detected: replace primary filter(s) now	Do not use the hood until you have replaced the primary filter with the secondary filter and put a new filter in the secondary position.
	Replace primary filter(s)	Replace the primary filter with the secondary filter and put a new filter in the secondary position.
	Replace HEPA/ULPA filter(s)	Order and replace the old filter with a new for either HEPA or ULPA.
<b>Fans</b> 	Fan speed control default	Change the settings of the fan back to personalized setting to get away from default use.
	Fan failure	Replace the fan(s) in failure with new boxes. See Section 8: Maintaining Your Filtered Hood in this manual.
<b>Maintenance</b> 	X Detector failure	Replace X detector.
	Relative Humidity (RH) sensor failure	Replace RH sensor.
	Internal RH <20%	Increase the ambient and filtered hood humidity or turn down alarm volume. See Appendix D: eGuard in this manual.
	Internal RH >80%	Decrease the ambient and filtered hood humidity or turn down alarm volume. See Appendix D: eGuard in this manual.
	Temperature sensor failure	Replace temperature sensor.
	Internal Temperature <5° C (<41° F)	Increase ambient and filtered hood temperature.
	Internal Temperature >40° C (>104° F)	Decrease ambient and filtered hood temperature.
	Internal Temperature >65° C (>150° F)	Decrease ambient and filtered hood temperature.
	Replace VOC Sensor	Order and replace. Section 8: Maintaining Your Filtered Hood in this manual.
	Replace Acid Sensor	Order and replace. Section 8: Maintaining Your Filtered Hood in this manual.
Replace Formaldehyde Sensor	Order and replace. Section 8: Maintaining Your Filtered Hood in this manual.	
Replace RH/Temperature Sensor	Order and replace. Section 8: Maintaining Your Filtered Hood in this manual.	
Replace Anemometer	Order and replace. Section 8: Maintaining Your Filtered Hood in this manual.	

Alarm	Error Message	Corrective Action(s)
	XXX sensor replaced on MM/DD/YY	Silence alarm on command module to learn new configuration.
	Primary/Secondary/HEPA filter(s) replaced on MM/DD/YY	Silence alarm on command module to learn new configuration.
	Number of installed filtration columns is different from the initial configuration	Use correct number of filtration columns.
	Number of installed filters is different from the initial configuration	Use the correct number of filters.
<b>Maintenance</b> 	X Primary filter(s) missing	If filter is there, check connection of filter or replace. If filter is not there, put the filter back.
	X back-up filter(s) missing	Olf filter is there, check connection of filter or replace. If filter is not there, put the filter back.
	Fan module(s) X missing	If fan is not there, put back or replace. If fan box is there, check connection or replace.
	The device is missing one or more base modules	Check connection between the base frames and the wiring going in to them (power supply to base frame). Replace if needed.
	VOC sensor	Check connection in fan module.
	Anamometer missing	If anamometer is not there, place back. If it is there, check connection or replace sensor and/or cable if needed. See Section 8: Maintaining Your Filtered Hood in this manual.
	RH/Temperature sensor missing	Replace the proper base frame. Section 8: Maintaining Your Filtered Hood in this manual.

If needed, contact Labconco to troubleshoot further.

## Appendix A: Parts List

Table A-1, Table A-2 and Figure A-1 indicate the location and catalog numbers for the following service, and replacement accessory components.

### Filtered Hood Replacement Parts

**Table A-1**

Item	Quantity Required	Catalog Number	Description
1	1	9823700	Valve, Labconco (Water) 1/4" Compression Fitting
	1	9823701	Valve, Labconco (Water) 3/8" Compression Fitting
	1	9817000	Valve, Labconco 1/4" Compression Fitting (AIR, GAS, VAC, NIT, etc.)
	1	9817001	Valve, Labconco 3/8" Compression Fitting (AIR, GAS, VAC, NIT, etc.)
	1	9823702	Valve, Labconco Deionized 1/4" Compression Fitting
	1	9823703	Valve, Labconco Deionized 3/8" Compression Fitting
	1	9818000	Nut, Valve Mounting. (Labconco)
2	1	9826800	WaterSaver Valve/Gooseneck -GRN
	1	9826801	WaterSaver Valve/Connector (VAC) – YEL
	1	9826802	WaterSaver Valve/Connector (AIR) – ORG
	1	9826803	WaterSaver Valve/Connector (GAS) – BLU
	1	9826805	WaterSaver Valve/Connector (HOT WATER) – RED
	1	9826806	WaterSaver Valve/Connector (CW) – GRN
	1	9826807	WaterSaver Valve/Connector (STEAM) – BLK
	1	9826808	WaterSaver Valve/Connector (NITROGEN) – BRN
	1	9826809	WaterSaver Valve/Connector (OXYGEN) – LIGHT GREEN
	1	9826810	Swivel Gooseneck only – GRN
1	9826812	Swivel Gooseneck only – WHITE	
3	1	9818700 thru 08	Knobs (GRAY, GRN, BLU, ORG, YEL, RED, WHT, BLK, BRN)
4	1	9818800	Hose Barb, GRAY – (NEUTRAL OR ARGON) – NOT SHOWN
	1	9818801	Hose Barb, GREEN - (COLD WATER) – NOT SHOWN
	1	9818802	Hose Barb, BLUE – (GAS) – NOT SHOWN
	1	9818803	Hose Barb, ORANGE – (AIR) – NOT SHOWN
	1	9818804	Hose Barb, YELLOW – (VACUUM) – NOT SHOWN
	1	9818805	Hose Barb, RED – (HOT WATER) – NOT SHOWN
	1	9818806	Hose Barb, WHITE – (DEIONIZED WATER) – NOT SHOWN
	1	9818807	Hose Barb, BLACK – (NEUTRAL OR STEAM) – NOT SHOWN
	1	9818808	Hose Barb, BROWN – (NITROGEN) – NOT SHOWN
	1	9819000	Nut, Hose Barb – NOT SHOWN
5	1	9825500	Label, Knob (contains all the labels)
6	1	9818900	Lens, Knob

Item	Quantity Required	Catalog Number	Description
7	1	9947100, 01, 02	115V Duplex Receptacle (GRAY) Right, Left 4' - 6', Left 8' w/ wires
	1	9818200	Cover Plate 115V Duplex
	1	9947103, 04, 05	115V GFCI Duplex Receptacle (GRAY) Right 4'-6', Left 8' w/ wires
	1	9818100	Cover Plate, 115V GFCI
	1	9818300	Cover Plate, Blank
	1	9851203	115V Duplex Receptacle, Left 10 FT - 12 FT (Gray)
	1	9851303	115V Duplex Receptacle, Left 16 FT (Gray)
	1	9851603	115V GFCI Duplex Receptacle, Left 10 FT - 12 FT (Gray)
8	1	9851703	115V GFCI Duplex Receptacle, Left 16 FT (Gray)
	1	9818400	Access Cover
9	1	9580304	Side Panel, no glass
	1	9580303	Side Panel, with window – Left
	1	9580302	Side Panel, with window – Right
	1	1885308	Screw, Machine #10-24 x .50 Phillips
	1	9586100; 9584701	Side panel, AIRO, 31.7"; Side panel, AIRO, 37.7"
10	1	9543900, 02, 04	Side Panel, Floor Mount Lower Base, 37.7", 43.7" or 55.7"
	1	9436500	Eco-Foil 3 FT
	1	9436501	Eco-Foil 4 FT
	1	9436502	Eco-Foil 5 FT
	1	9436503	Eco-Foil 6 FT
11	1	9436505	Eco-Foil 8 FT
	1	1850000	Pulley, Front, 2" Dia. Nylon
12	1	4949902	Cable, Sash 130" – NOT SHOWN
	1	9414017	Cable Replacement Kit, Echo
	1	9545800	Weight Support Bracket Kit (not available for 360° visibility)
13	1	9709300	Plastic Pulley, (Rear 2")
14	1	9713300	Bumper, Rubber – NOT SHOWN (lower sash bumper)
15	1	1934102	Bronze Bearing, Flanged Front, .375 OD x .281 ID – NOT SHOWN
16	1	1920100	Clamp, Cable Replacement – NOT SHOWN
17	1	9935800	Threaded Connector – NOT SHOWN (to attach weight to cable)
18	1	9582710, 11	Wiring Harness (may be used to power optional air monitor)
19	1	9431301, 02, 03, 05, 06, 07	Front Panel, 4 FT, 5 FT, 6 FT, 8 FT, 3 FT AIRO & 4 FT AIRO
	1	9582600	Echo Label, Front Panel
	1	9582601	Airo Label, Front Panel – NOT SHOWN
20	1	9578100,01,02,03	Rear Panel, 360° visibility only 4 FT, 5 FT, 6 FT, 8 FT
21	1	9584910	Wing Kit (optional for Floor-mounted Echo) – NOT SHOWN

## Neutrodine (by Erlab) Filtration Technology Replacement Parts

Table A-2

Item	Quantity Required	Catalog Number (10/2020 to 1/2025)	Catalog Number (2/2025 to Current)	Description
22	1	9575003	9575043	3 FT (M1) Complete Airo Technology Package, no filters
	1	9575004	9575044	4 FT (M2) Complete Echo/Airo Technology Package, no filters
	1	9575005	9575045	5 FT (M3) Complete Echo Technology Package, no filters
	1	9575006	9575046	6 FT (M4) Complete Echo Technology Package, no filters
	1	9575008	9575048	8 FT (M5) Complete Echo Technology Package, no filters
	1	9575013	9575053	3FT (M1) Complete Airo w/ Acid Technology Package, no filters
	1	9575014	9575054	4FT (M2) Complete Echo/Airo w/ Acid Tech. Package, no filters
	1	9575015	9575055	5FT (M3) Complete Echo w/ Acid Technology Package, no filters
	1	9575016	9575056	6FT (M4) Complete Echo w/ Acid Technology Package, no filters
	1	9575018	9575058	8FT (M5) Complete Echo w/ Acid Technology Package, no filters

Item	Quantity Required	Catalog Number (10/2020 to 1/2025)	Catalog Number (2/2025 to Current)	Description
22	1	9575023	9575063	3 FT (M1) Complete Airo w/ Formaldehyde Tech. Package, no filters
	1	9575024	9575064	4 FT (M2) Complete Echo/Airo w/ Formaldehyde Tech. Pack, no filt.
	1	9575025	9575065	5 FT (M3) Complete Echo w/ Formaldehyde Tech. Package, no filt.
	1	9575026	9575066	6 FT (M4) Complete Echo w/ Formaldehyde Tech. Package, no filt.
	1	9575028	9575068	8 FT (M5) Complete Echo w/ Formaldehyde Tech. Package, no filt.
	1	9575033	9575073	3 FT (M1) Complete Airo Hepa Only Tech. Package, no filters
	1	9575034	9575074	4 FT (M2) Complete Echo/Airo Hepa Only Tech. Package, no filters
	1	9575035	9575075	5 FT (M3) Complete Echo Hepa Only Tech. Package, no filters
	1	9575036	9575076	6 FT (M4) Complete Echo Hepa Only Tech. Package, no filters
23	1, 2, 3, 4, 5	9577420	9577460	Neutrodine molecular carbon filter (rotate every two years)
	1	9577447	9577487	PCB, Filter, Programmed
24	1, 2, 3, 4, 5	9577421	9577461	HEPA Filter, with blade frame
	1, 2, 3, 4, 5	9577430	9577470	Replacement HEPA, (no blade frame)
	1, 2, 3, 4, 5	9577439	9577439	Junction frame, HEPA to Neutrodine
25	1, 2, 3, 4, 5	9577422	9577422	GFH Pre-filter (inside light box) Standard
	1, 2, 3, 4, 5	9577423	9577423	GFH Pre-filter (inside light box) For trapping inorganic acids
	1, 2, 3, 4, 5	9577424	9577424	GFH Pre-filter (inside light box) For trapping Ammonia
26	1	9577435	9577435	Command Module
	1	9577442	9577442	Cable, Command Module to Base Frame
27	1	9577425	9577465	Base Frame (with LED Light Bar)
	1	9577445	9577445	Cable, Base Frame to Power Supply
	1	9577448	9577488	PCB, Base module
28	1	9577427	9577467	Fan Box (Provide S/N... Yellow Sticker = Belong Fan)
	1	9577428	9577428	Acid Sensor, Fan Box (Provide S/N... Yellow Sticker = Belong Fan)
	1	9577429	9577429	Formaldehyde Sensor, Fan Box (Provide S/N... Yellow Sticker = Belong Fan)
	1	9577432	9577432	Solvent Sensor, Fan Box Front Plate
	1	9577433	9577473	Acid Sensor, Fan Box Front Plate (Provide S/N... Yellow Sticker = Belong Fan)
	1	9577434	9577474	Formaldehyde Sensor, Fan Box Front Plate (Provide S/N... Yellow Sticker = Belong Fan)
	1	9577446	9577486	PCB, Fan (Provide S/N... Yellow Sticker = Belong Fan)
	1	9577457	9577457	Fan Assembly Only (when reusing Fan PCB) (Provide S/N... Yellow Sticker = Belong Fan)
29	1	9577436	9577436	Anemometer
	1	9577443	9577443	Cable, Anemometer to Power Supply
30	1	9577440	9577440	Power Supply, Derivation Box
	1	9577437	9577437	Power Supply Adapter Tech for 3 FT, 4 FT & 5 FT
	1	9577438	9577438	Power Supply Adapter Tech for 6 FT & 8 FT
31	1	9577456	9577456	Ethernet Cable for Smart Module, GFH3-ERLAB

Figure A-1

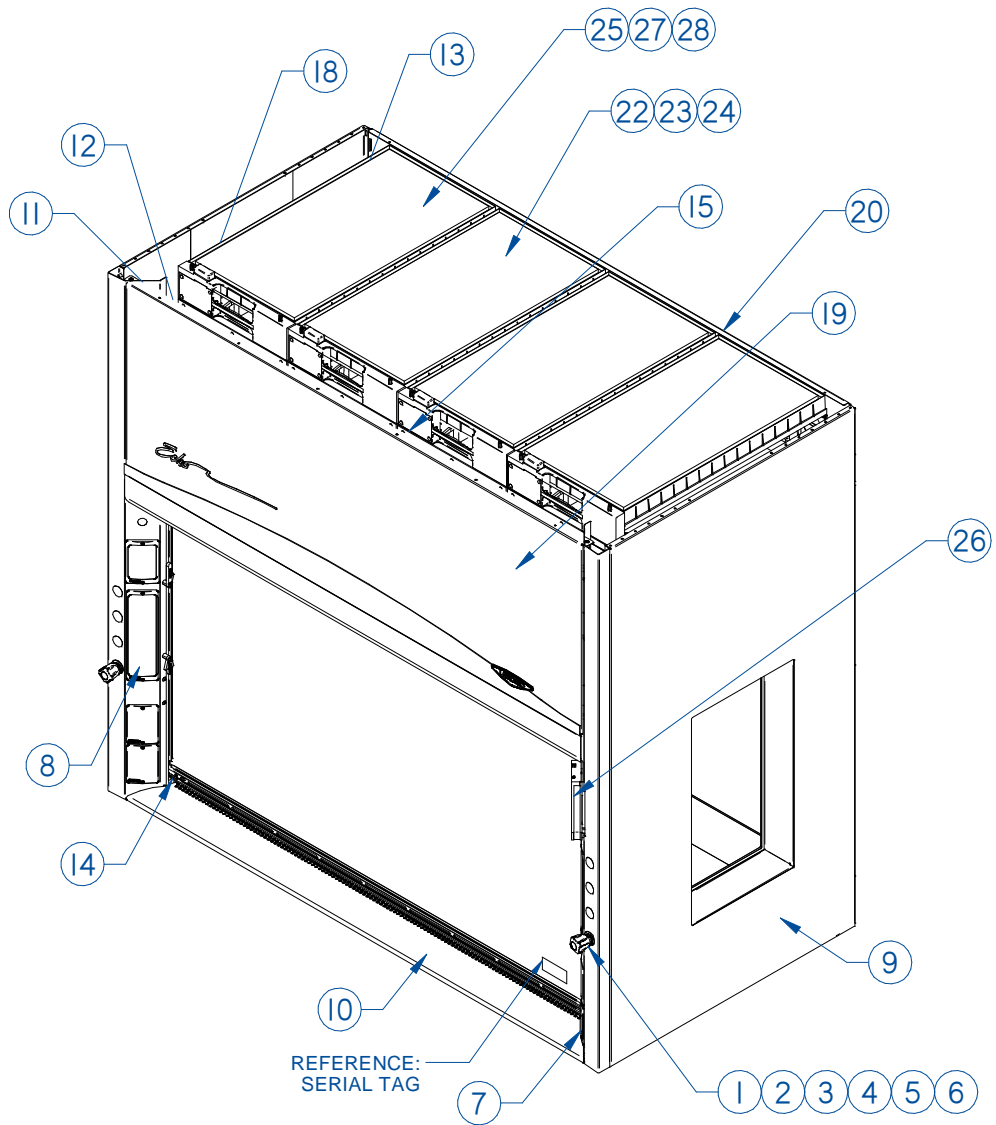

## Appendix B: Dimensions

Table B-1 and Figure B-1 indicate the benchtop filtered hood product dimensions. Table B-2, B-3 and Figure B-2 indicate floor mounted filtered hood product dimensions. All dimensions shown are in inches unless specified.

### Protector® Echo™ Bench Top Filtered Fume Hood

Table B-1

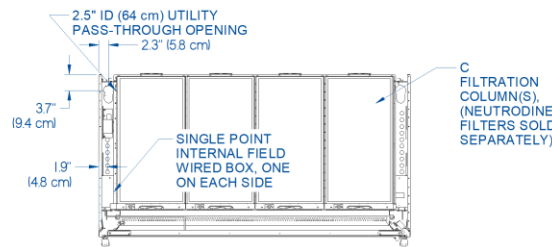

Width	A	B	C	D
4 FT	48.0	38.2	2 ea	27.9
5 FT	60.0	50.2	3 ea	36.9
6 FT	72.0	62.2	4 ea	49.9
8 FT	96.0	86.2	5 ea	66.9

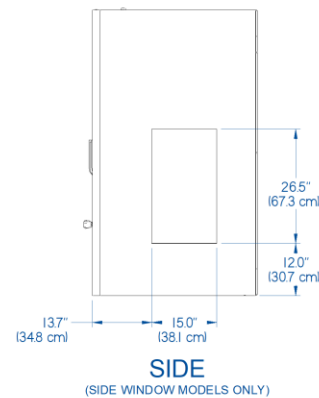
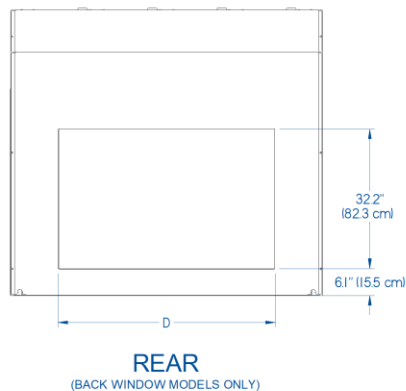
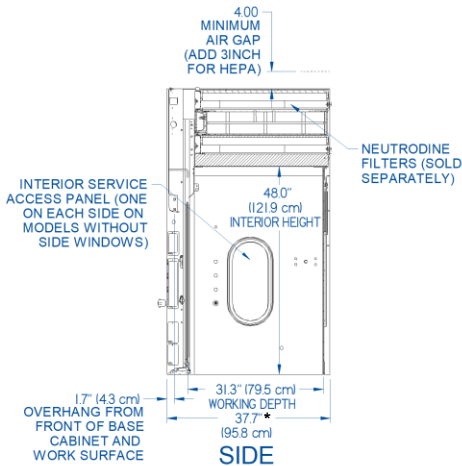
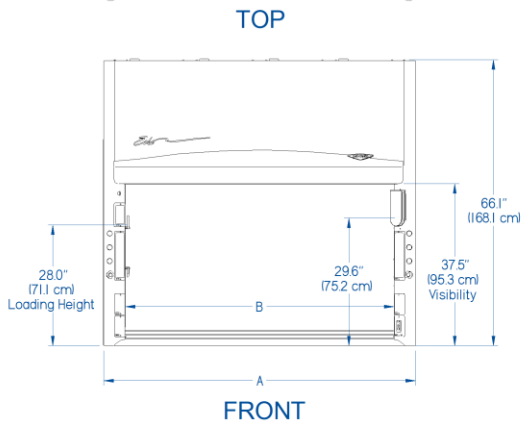

\*The 360 glass models have a depth of 38.1"

# Protector® Echo™ Floor Mount Filtered Fume Hood

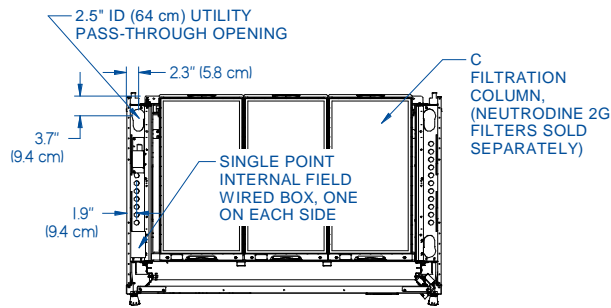

TOP

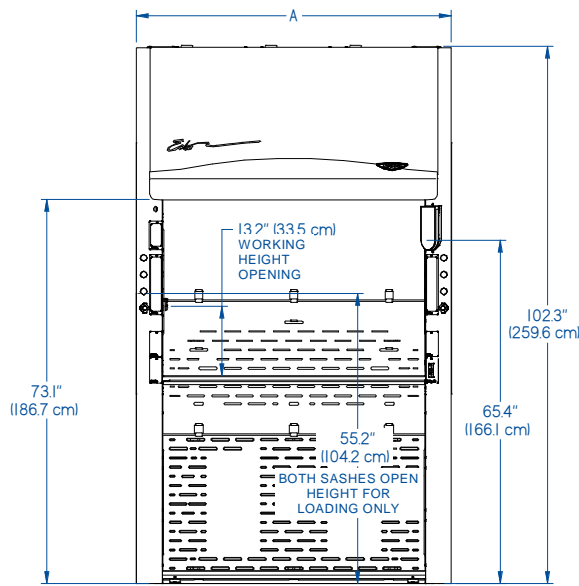

FRONT

Figure B-2

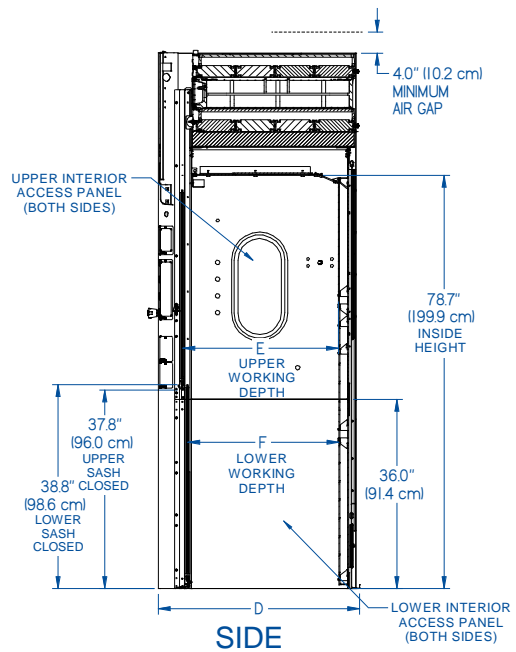

SIDE

Table B-2

Width	A	B	C
4 FT	48.0	38.2	2 ea
5 FT	60.0	50.2	3 ea
6 FT	72.0	62.2	3 ea
8 FT	96.0	86.2	5 ea

Table B-3

D	E	F
37.7	29.7	28.7
43.7	35.7	34.7
55.7	47.7	46.7

## Protector® Airo™ Bench Top Filtered Fume Hood

Figure B-3, B-4 & B-5 indicates small 54.2" height Airo product dimensions. All dimensions shown are in inches unless specified.

Figure B-3

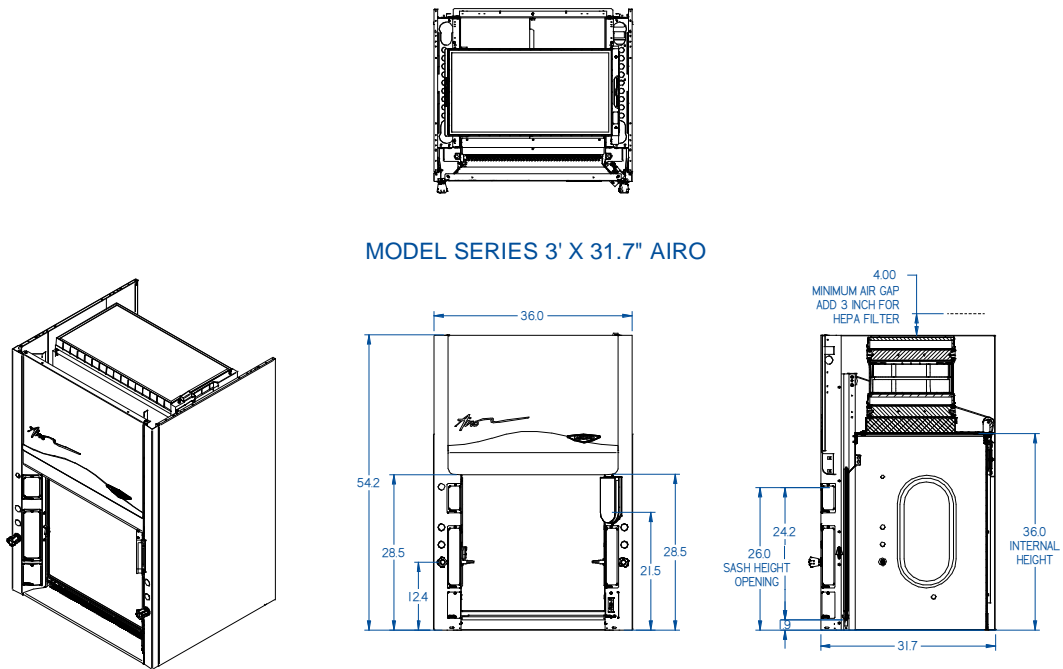

Figure B-4

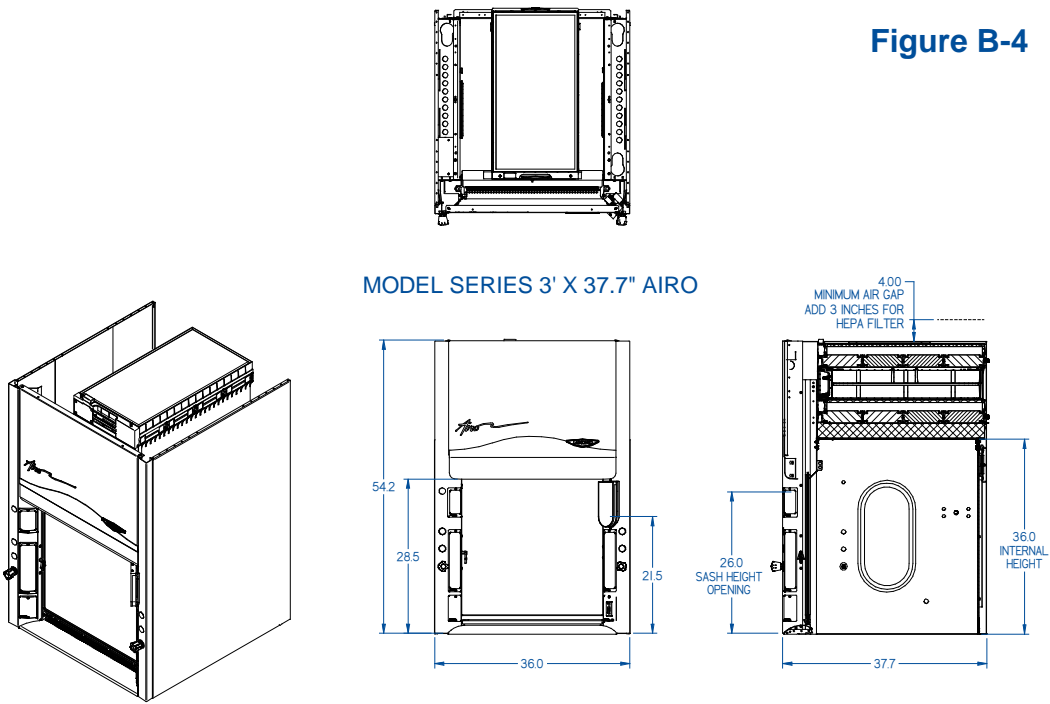
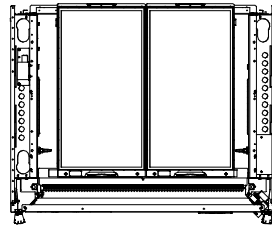
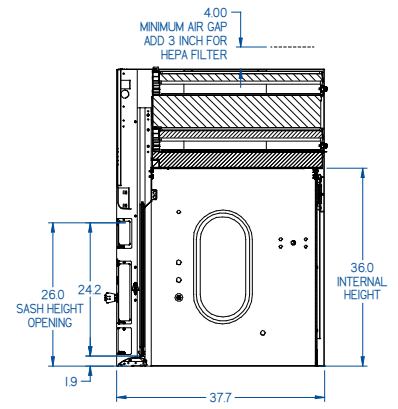
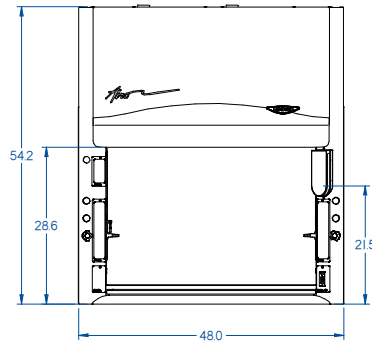
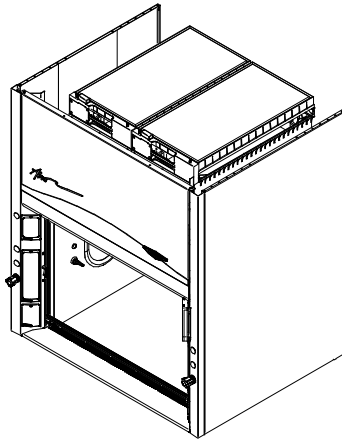

Figure B-5



MODEL SERIES 4' X 37.7" AIRO



## Appendix C: Specifications

---

### Environmental Conditions

- Indoor use only.
- Maximum altitude: 10,000 feet (3,048 meters).
- Ambient temperature range: 41° to 104°F (5° to 40°C).
- Maximum relative humidity: 80% for temperatures up to 88°F (31°C), decreasing linearly to 50% relative humidity at 104°F (40°C).
- Main supply voltage fluctuations not to exceed  $\pm 10\%$  of the nominal voltage.
- Transient over-voltages according to Installation Categories II (Over-voltage Categories per IEC 1010). Temporary voltage spikes on the AC input line that may be as high as 1500V for 115V models and 2500V for 230V models are allowed.
- Used in an environment of Pollution degrees 2 (i.e., where normally only non-conductive atmospheres are present). Occasionally, however, a temporary conductivity caused by condensation must be expected, in accordance with IEC 664.
- Electrical Ratings:

**Table C-1**

Volts AC	Phase	Cycle	AMP*
115	1	50/60	10
115	1	50	10
115	1	60	10
230	1	50/60	5
230	1	50	5
230	1	60	5

Does not include current rating of receptacles.

# Wiring Diagram

Figure C-1

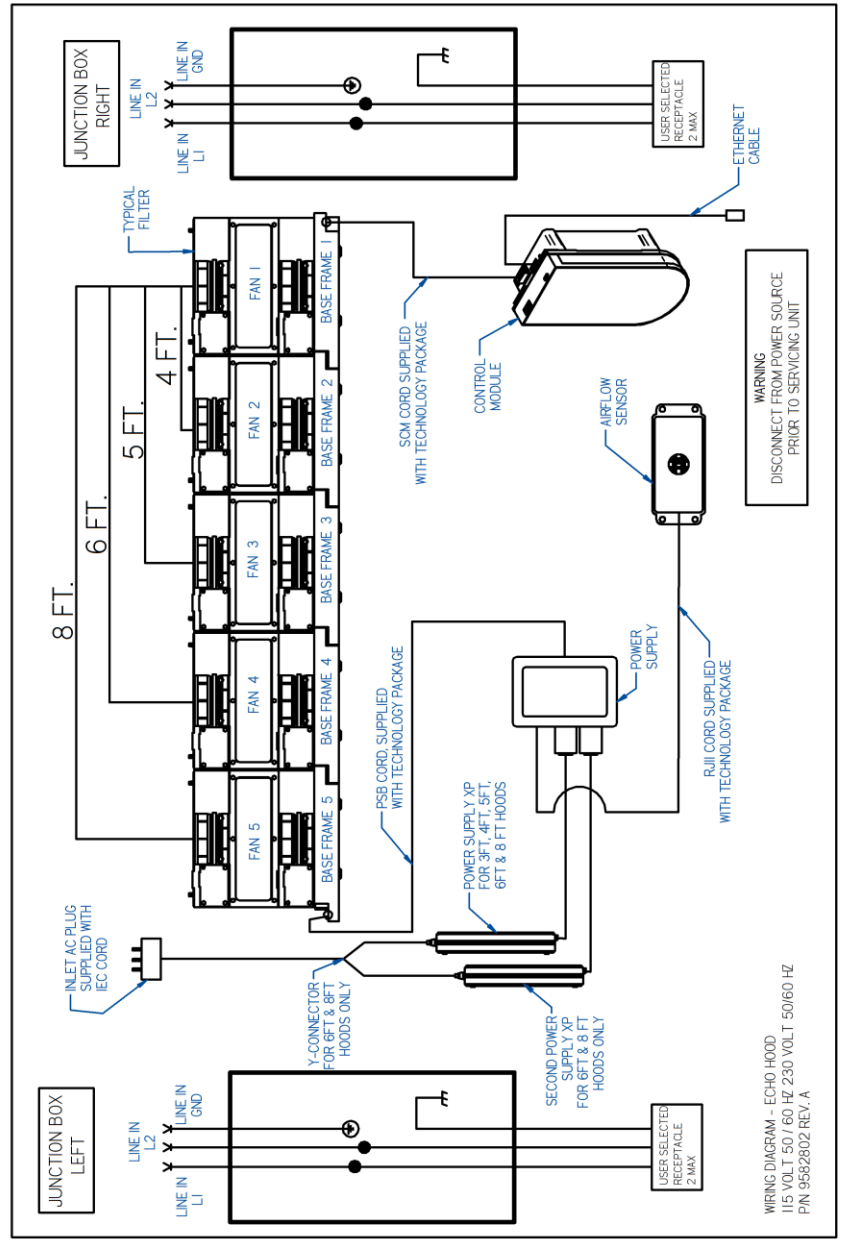

## Appendix D: eGuard

The filtered hood operating system provides user control with the touch pad command module and a Wi-Fi-connection interface called eGuard. eGuard connects the filtered hood to the user's phone, laptop or tablet either through an Ethernet cable into the command module or by connecting the mobile device to the network of the filtered hood that will be used.

### Command Module

Below is a graphic of the command module with callouts for the different buttons and icons:

**Figure D-1**

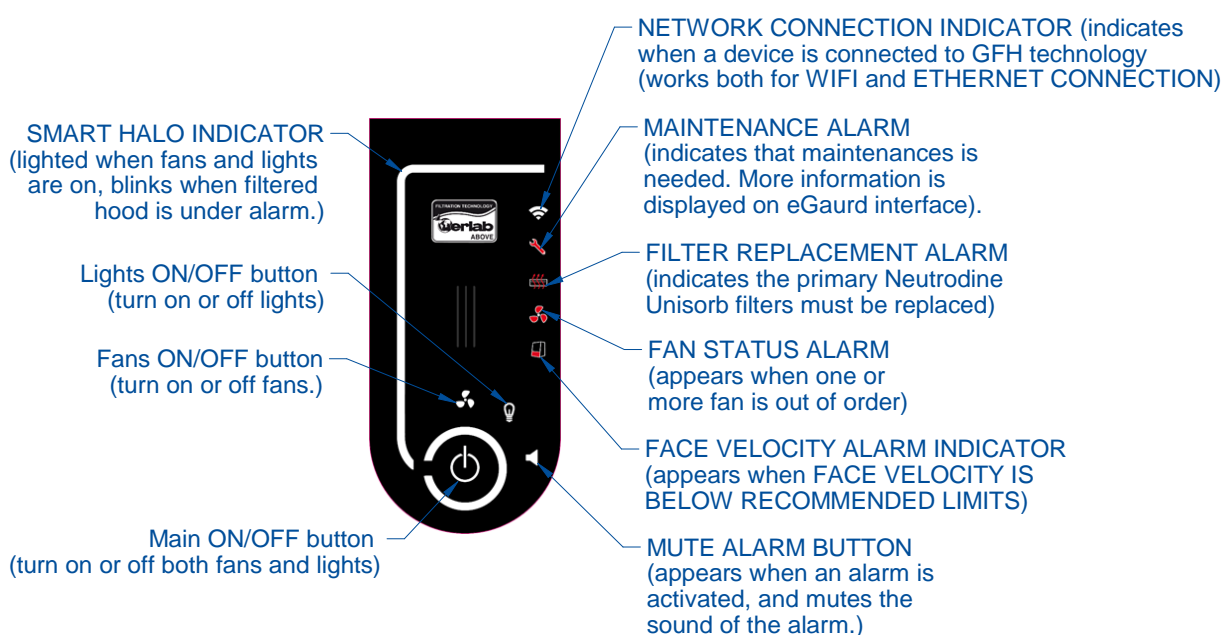

Only the fan, light and main power buttons are available when the hood is on and in use. The mute alarm button appears when an alarm occurs and disappears once pressed, or after the alarm is resolved. You cannot unmute the alarm chime once pressed, but the alarm sound will resume after 10 minutes if the error is not resolved. The other icons are simplified communication of what is happening with the hood. The network shows only when your device is connected to the hood. The icon being dark does not mean it lacks the WIFI or Ethernet to connect, only that the connection is not currently being made. All other icons are displayed red because they are alarms and disappear when the error is resolved.

### *Index: Connecting to your filtered hood with eGuard*



For connecting your phone or tablet to the filtered hood with WIFI:

1. Open the network selector on your device.

2. Select the Wi-Fi network: **GFH-XXXXX-XXXX**  
(the **XXXX** is the serial number of the filtered hood).
3. Password is: **GFH-2018**
4. Open an internet browser (Google Chrome, Mozilla Firefox... etc.) and enter the following address in the browser menu: <http://192.168.1.1>

This will open a webpage that is the eGuard *index* home screen. The homepage has three sections called INFO, LOGS and SETTINGS.



For connecting the filtered hood to a laptop:

1. Connect an Ethernet cable to the laptop from the command module.
2. Configure the Ethernet parameter of computer:
  - a. Protocol TCP/IP V4
  - b. IP address: 192.168.0.201
  - c. Subnet mask: 255.255.255.0
3. Open an internet browser (Google Chrome, Mozilla Firefox... etc.) and enter the following address in the address menu: <http://192.168.0.205>
4. See Figure 6-3 for more details.

## INFO

INFO displays the usage time of the filtered hood as well as the sensor values of the temperature and humidity of the filtered hood. The main purpose for the info page is the safety state of the following categories: Face Velocity, Fan, Filtration and Maintenance. These correspond to icons on the command module. When the ventilation is off, the dots beside these categories are gray. Once the ventilation is activated and the filtered hood is running correctly, the dot turns green as shown in Figure D-2.

If any error occurs, that displays with a red dot and the drop down menu will show the alarm code, giving insight to what is wrong. The icon and alarm will match the command module's alarm, but through eGuard you will have more information of the specific problem. If more than one error occurs under a category there will be more than one error code displayed. For example, there could be "Anemometer out of order" and "Low face velocity" under the same icon. This means two areas must be addressed before the alarm will cease.

**Figure D-2**

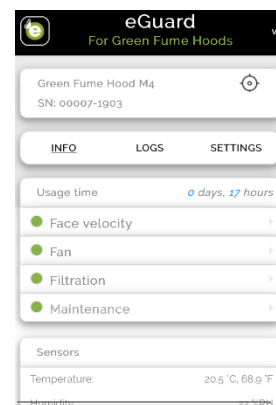

**Figure D-3**

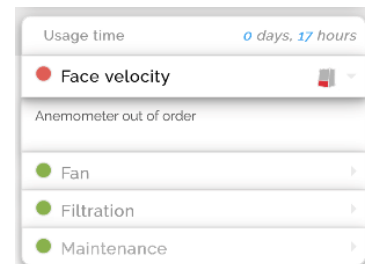

## LOGS

LOGS has record of this filtered hood's specific event history and will keep track of alarms and power on/off of the hood. Every event recorded will have a date and time stamp and the code in one scroll through menu. Date and time of every alarm occurring and subsequently cleared, as well as general use records will be documented all in one place. To save or share the data, the logs will have to be exported. Find the green button **[Export data]** at the bottom of the log page. Clicking that button will give you two options: **View** and **Download**.

- **View** will open a page that displays all of the recordings logged in one place. The view option will be easiest to read on a laptop or tablet.
- **Download** will be an openable document of your choosing sent to the downloads folder of your device.

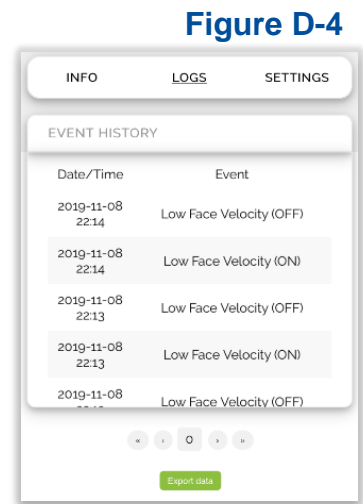

## SETTINGS

Finally, SETTINGS is the last option of the eGuard homepage. This page requires a username and password to enter. Use the following information to log-in, as shown in Figure D-5:

Username: GFH

Password: 2018

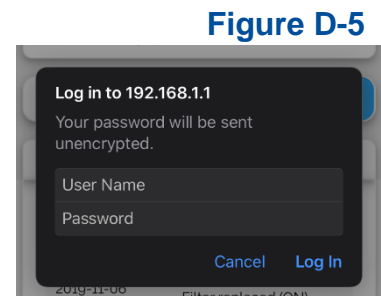

Here the sensor sensitivity can be adjusted. Other sensors like the temperature trigger range, humidity trigger and light and sound intensity is found under the settings page.

## Name the Hood

The first feature of the settings page is the ability to set and/or change the name of the filtered hood. This will help keep track of the filtered hood as well as differentiating multiple filtered hoods if you have more than one in your lab. To change the name of the hood, type your desired name into the box and press **[Save]**. The changes will be updated.

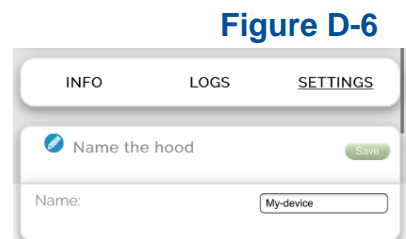

## Date/Time

Also available for manipulation is the date and time. You must check and set the correct date and time. Usage time from the INFO page and every recording in the LOGS event history requires an accurate date and time. This will also keep track of operation to prevent using filtration too long.

Figure D-7

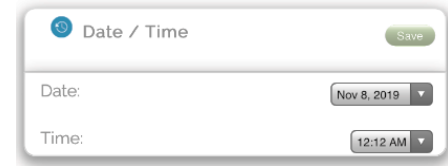

Use drop down arrows to set the correct date and time. Once complete, press **[Save]**.

## Configure your Connection

Here, options for the filtered hood and how to connect to eGuard are laid out. You can limit connection options, for example only allow Ethernet connection. You can also turn on and off Bluetooth, Wi-Fi or Data Sending. The screen will look like Figure D-8 and to enable/disable touch the on/off toggle. If it is enabled it will appear green, if disabled it looks gray. After making any desired changes you must touch **[Save]** for the new settings to be implemented in the filtered hood. The gears are to adjust the settings for the Wi-Fi and Ethernet. Shown in Figure D-8, these configurations can be modified to fit your needs. When finished making changes, touch **[Save]** to complete the update to the filtered hood.

Figure D-8

## Startup

The default setting for the filtered hood start up is 'Ventilation + Lighting'. You noticed when first pressing the power button on the command module the fans and lights turned on at the same time. To change the startup, use this section of the settings page. Click the drop down arrow to select from the startup options:

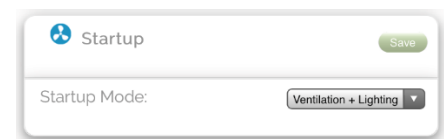

- Ventilation + Lighting
- Ventilation

When you've made the desired change to the startup setting, touch **[Save]** to implement it in the filtered hood.

Figure D-9

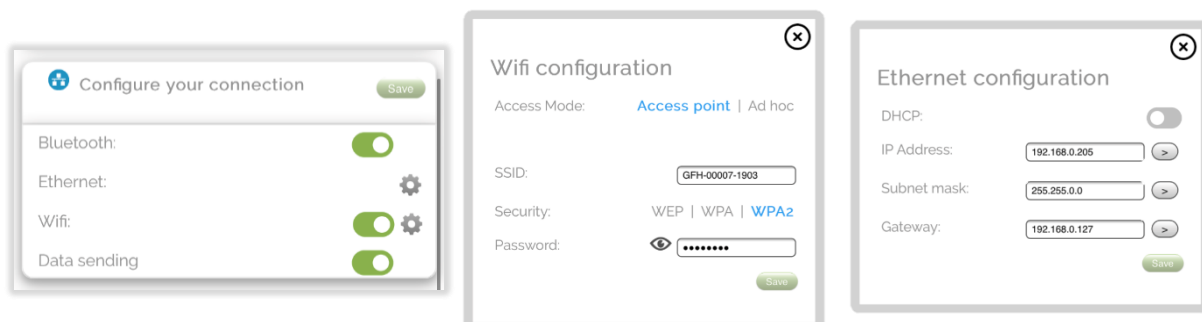

## Sensor Sensitivity

Here the sensitivity of the filtered hood's sensors can be adjusted. In addition, background noise can be taken in to account, but should only be used after investigation. Premature use of the option can cause limitations of the sensor that limit safety unnecessarily. No numeric value can be seen for the solvent adjustment, but a range is still used and displayed for the setting bar. To change the sensitivity, move the bar to your desired level and touch **[Save]**. Approximate values for the Solvent Sensitivity is as follows:

Low Sensitivity	=	4,000 mV
Medium Low Sensitivity	=	3,500 mV
Medium Sensitivity	=	3,000 mV
Medium High Sensitivity	=	2,500 mV
High Sensitivity	=	2,000 mV

Figure D-10

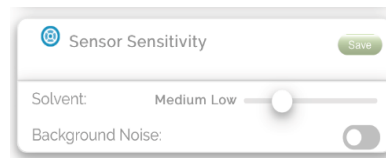

## Other Sensors

These sensors involve temperature triggers and a humidity trigger. The temperatures should be set to the lowest and highest acceptable working environment for your filtered hood use. When set, the filtered hood will warn you when the internal temperature is outside of your range. For example, if the work area drops lower than the Temperature trigger 1 value, a maintenance alarm will appear.

Similarly, the filtered hood will alarm if the internal relative humidity becomes greater than the trigger value. The errors show on the command module and the eGuard INFO page. The default sensor values are shown in Figure D-11. To manipulate the triggers, drag the toggle to the desired values and touch **[Save]**.

Figure D-11

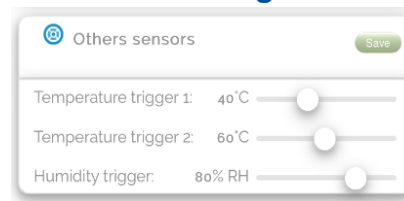

## Others

The final options for the setting page is the volume and brightness for the filtered hood. The volume manipulates the command module sound. Startup chimes and error bells loudness can be increased and decreased as needed for the filtered hood environment. The internal work light can also be dimmer or brighter. To change both of these, simply adjust the toggle to the desired percentage touch **[Save]**. Default values are shown in Figure D-12.

Figure D-12

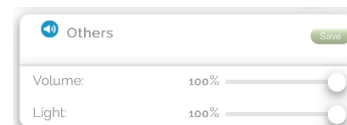



## Update: Connecting to your filtered hood with eGuard

Another page with options for manipulation is the update section of eGuard. Your phone, tablet or laptop still needs to be connected to the filtered hood:

1. Open the network selector on your device.
2. Select the Wi-Fi network: **GFH-XXXXX-XXXX**  
(the **XXXX** is the serial number of the filtered hood).
3. Password is: **GFH-2018**
4. Open an internet browser (Google Chrome, Mozilla Firefox... etc.) and **enter the following address in the browser menu:** <http://192.168.1.1/update.html>  
Where a username and password is required:
  - a. Username: **ach**
  - b. Password: **ach**

This will open a webpage that is the eGuard **update** home screen. The homepage has three sections called INFO, LOGS and SETTINGS. INFO is the only section that makes <http://192.168.1.1/update.html> different from <http://192.168.1.1/index.html> (discussed previously in [Appendix D: eGuard](#)).

For connecting the filtered hood to a laptop with Ethernet:

1. Connect an Ethernet cable to the laptop from the command module.
2. Configure the Ethernet parameter of computer:
  - a. Protocol TCP/IP V4
  - b. IP address: 192.168.0.201
  - c. Subnet mask: 255.255.255.0
3. See Figure 6-3 for more details.
4. Open an internet browser (Google Chrome, Mozilla Firefox... etc.) and **enter the following address in the address menu:** <http://192.168.0.205/update.html>  
Where a username and password is required:
  - a. Username: **ach**
  - b. Password: **ach**

## INFO

More filtered hood adjustments are available in the INFO (update) section. Adjustments like fan and sensor settings, factory reset, server configuration, Ethernet and maintenance settings.

### Fan Settings

In this section the rotation fan speed set points can be managed. *Working Setpoint* is the rotation speed of the fans when the sash is open. When the sash is open, the fans will be rotating at this speed. There is also *Closed Setpoint* which is the rotation speed of the fans when the sash is closed. When the ventilation is on but the sash is not open, the fans will rotate at this set point. *Force Start* authorizes the start of

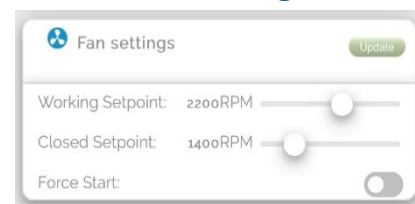

Figure D-13

the fans even if there are no primary filters. Figure D-13 shows the default settings of the filtered hood. To make changes adjust the switches as needed and touch **[Update]**.

The range of the rotation speed possible by the fan boxes are 1,000 to 3,000 rpm. It is recommended to stay at or below 2,400 – 2,600 rpm (or 2,600 – 2,800 with optional HEPA filters) for a Working Setpoint as it will effect dwell time. When you increase fan speed, you decrease the dwell time, and subsequently decrease the life and effectiveness of the filtration technology.

### Sensor Settings

This setting is used to find the lowest molecule S (S is for organic vapors) value. Molecule is what indicates the saturation level of the main carbon filters. When the filtered hoods is operating, we are looking for the lowest value over the past 7 days or 72 hours. This is the way to restart the molecule S Vo.

**Figure D-14**

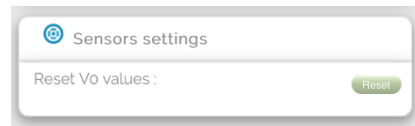

**Figure D-15**

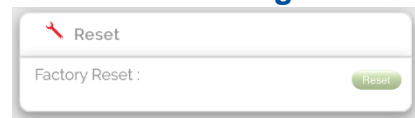

### Factory Reset

A reset, normally not required, may be needed if the filtered hood IP address and/or password was changed and forgotten. To conduct a factory reset, use the section shown in Figure D-15. Touch **[Reset]** to return the filtered hood to its default values as follows:

**Table D-1**

Factory Reset Default Values	
Ethernet IP Address	192.168.0.201
Subnet Address	255.255.0.0
Gateway Address	192.168.0.127
WIFI IP Address	192.168.1.1
SSID	GFH-SN
Access point mode	No password
Threshold MDS/MDA/MDF	Medium Sensitivity
Background noise option	Not checked
Fan rotation speed: Working setpoint	2400-2800 RPM
Fan rotation speed: Closed setpoint	1400 RPM
Alias (Name the Hood)	My device
Date	Date before reset
Bluetooth, eGuard & WIFI	Activated (All)
Start-up mode	Ventilation + Lighting
Sound Signal & Lighting	100% (Both)
Temperature trigger: 1	40°C
Temperature trigger: 2	60°C
Humidity	80%
History	Empty

## eGuard Server configuration

The eGuard server can be changed. Shown in Figure D-16 is the default. If changes are needed, simply type the desired server settings in the boxes. To make changes touch **[Update]**. The same can be done for the server port.

**Figure D-16**

## Ethernet

Ethernet settings can be modified here. Shown is the default, but adjustment is possible. To make changes touch **[Update]**.

**Figure D-17**

## Maintenance

Test to see the connection with eGuard cloud. The display provides the test results after touching **[Test]**. It is also possible to change the CPU SN. If you want the computer serial numbers to be different (for example, easier to remember, similar to other filtered hoods, easier to identify, coincide with room number hood is in, etc.) type in what you want and touch **[Change]** for it be affective. The anemometer is not possible to change but is shown for reference.

**Figure D-18**

## eGuard Access Summary

**Table D-2**

Address	Username	Password	Description
192.168.1.1/ <b>index.html</b>	*	*	Displays operation summary and alarm messages. Shows internal time, temperature and relative humidity values.
192.168.1.1/ <b>log.html</b>	*	*	Records of use and events that occur for the filtered hood. Can be exported.
192.168.1.1/ <b>settings.html</b>	gfh	2018	Includes options to change: Names, Time/Date, hood connection, Start up, Sensor Sensitivity, Temperature, Volume & Brightness
192.168.1.1/ <b>update.html</b>	ach	ach	Includes options to change: Fan Speeds, Sensor Settings, Factory Reset, Server Configuration, Ethernet Options, Connection Test

\*Index and Log do not require a username or password.

## Appendix E: Setting up the Protector Echo Floor-mounted Filtered Hood

---

Have the site for the floor-mounted filtered hood properly prepared ([See Section 2: Before You Install](#)). Read this chapter to learn how to:

- Unpack and move the floor-mounted filtered hood.
- Set up the floor-mounted filtered hood.

Your Protector Echo Floor-Mounted (Walk-In) Filtered Hood was shipped as ten main component assemblies located on three shipping skids. The skids are as follows:

1. Lower base and sashes
2. Upper cabinet
3. Lower sash track, sash weights, corner posts, service fixtures, electrical connections, baffles, header, and front panel



The following tools are required to unpack and install the equipment:

- Common plumbing equipment
- Common electrical installation tools
- Wrenches, ratchets, nut driver set and sockets of the following size:  
5/16-inch, 3/8-inch, 7/16-inch & 1/2-inch
- Flat-blade screwdriver
- Phillips screw driver
- Carpenter level



The following safety precautions must be followed by all personnel unpacking the equipment.

- Wear safety glasses
- Wear gloves
- No loose fitting clothes
- Wear close-toed shoes
- Follow safe-lifting practices (do NOT attempt to lift this product without specialized lifting equipment certified to lift up to 1000 lbs.)



The Protector Echo Floor-Mounted Filtered Hood models weigh between 700 to 1500 lbs. (318-675 kg). The multiple shipping pallets allow for lifting with a mechanical lift truck or floor jack. If you must lift the filtered hood manually, follow safe-lifting guidelines.

Les modèles filtrée protège-capot Echo monté au plancher pèsent entre 700 à 1500 livres. (318 à 675 kg). Les multiples palettes d'expédition permettent de levage avec un chariot élévateur mécanique ou prise de parole. Si vous devez soulever la hotte manuellement, suivre les directives safe-levage.

## Unpacking

Carefully remove the shrink-wrap and/or outer carton and inspect the product for damage that may have occurred in transit. If the product is damaged, take pictures of the product and the outer packaging, and notify the delivery carrier immediately. Retain the entire shipment, including outer packaging, intact for inspection by the carrier.



**Note:** Do not return goods without the prior authorization of Labconco. Unauthorized returns will not be accepted. If your hood was damaged in transit, you must file a claim directly with the freight carrier. Labconco Corporation and its dealers are not responsible for shipping damages.



Do not move the filtered hood by tilting it onto a hand truck.  
Ne pas déplacer le capot filtrée en l'inclinant sur un camion de main.

## Remove from Shipping Skid



**Note:** Leave the filtered hood attached to its shipping skid until it is as close to its final location as possible. Move the hood by using a suitable floor jack, or by placing a furniture dolly underneath the skid. Do not move the hood by tilting it onto a hand truck.

After you verify the filtered hood components, move the hood to the installation location. Follow the steps listed to remove the shipping skids from the lower base and upper cabinet.

1. Remove the side panels by unscrewing the Phillips screws.
2. Find the hardware (bolts, washers, nuts) that attach the filtered hood to the skid and remove the hardware.

## Lower Base Installation

Remove the left and right side panels for accurate placement of the lower cabinet assembly. Remove both vertical-rising sashes shipped on the same skid as the lower base. Place the sashes in a location where they will not get lost or damaged. Position the lower base on a level floor surface or an optional purchased floor surface. If an optional floor surface is purchased, it should be positioned on the existing floor prior to placement of the lower cabinet installation.

## Upper Cabinet Installation

Remove the upper cabinet assembly side panels. Place the upper cabinet assembly on top of the lower base assembly. Be sure to clear the lower base assembly during placement. Mount the lower base to the upper cabinet using the ¼-20 hex head screws, lock washers, and nuts included in the hood package. Run a bead of white RTV sealant between the upper and lower liner sections once properly aligned. See Figure E-1

Figure E-1

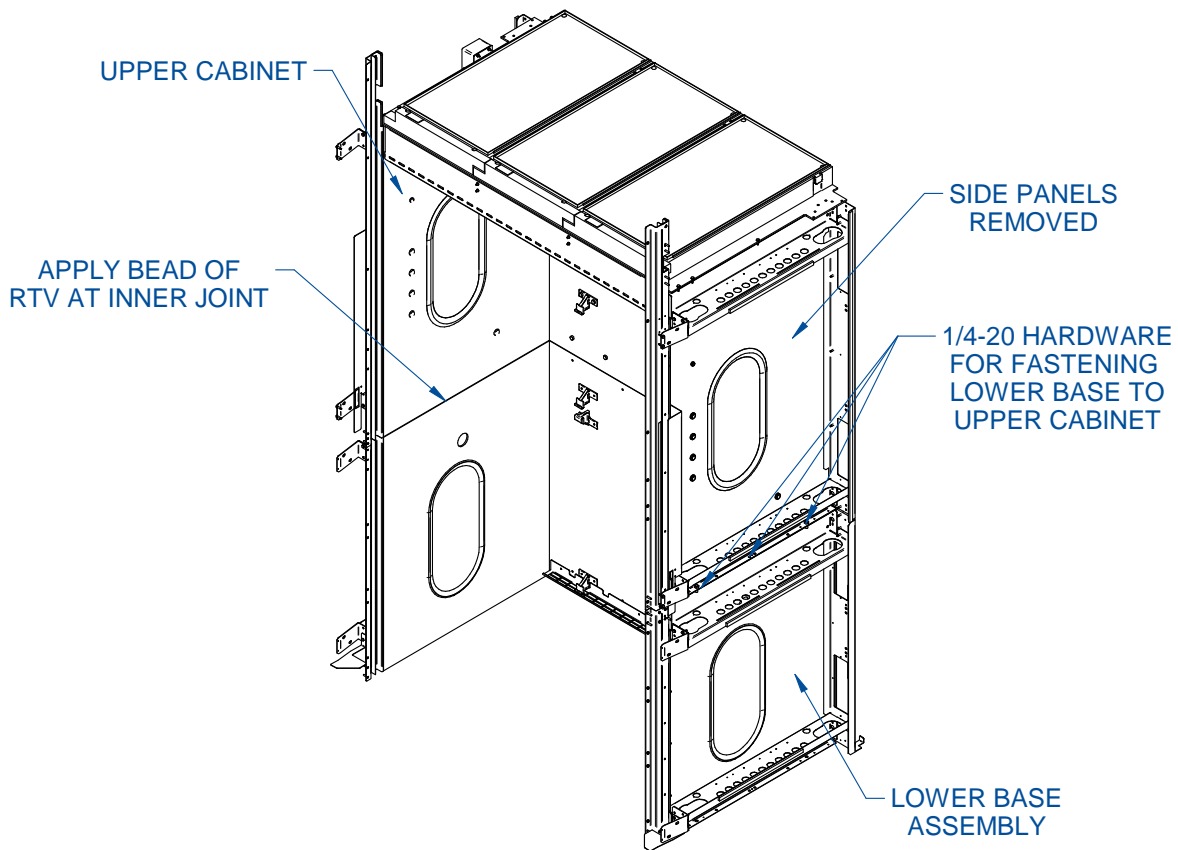

## Sash Installation

Locate the vertical sashes previously removed from the lower base skid. Locate the sash weights on the third skid.



**Note:** The sash weight itself was individually matched for this specific filtered hood and should not be exchanged on any other unit.

## Vertical Sashes

Both upper and lower sash tracks are attached to the side frames. The hood should be at a pre-assembled state: the upper cabinet bolted to the lower base. Bring the sides back and adjust the sash tracks left and right to assure that each sash will work properly and tighten all hardware.

## Sash Weights

The sash weights have been secured to the shipping skid. Remove the weights from the skid and attach them to the respective sash cables using the hooks provided.

With the sashes in place, install the counterbalance weights. The large single sash weight is installed in the middle and attached to the lower rear sash. The two individual sash weights counterbalance the front vertical-rising sash; these weights have rollers and ride in the rear sash tracks that straddle the middle sheet metal sash weight. Install the rear weight tracks for the individual sash weights with the #10-24 screws and #10-24 KEPS nuts supplied. See Figures E-2 and E-3. It is important the front upper and lower sash tracks are fully aligned. Use the strap plates to secure this alignment. Once the sashes are aligned and operating freely, secure the lower base to the floor with sealant or fasteners. (Note: Hardware not supplied due to installation variables.) Securing the lower base will ensure the sashes will work freely.

Figure E-2

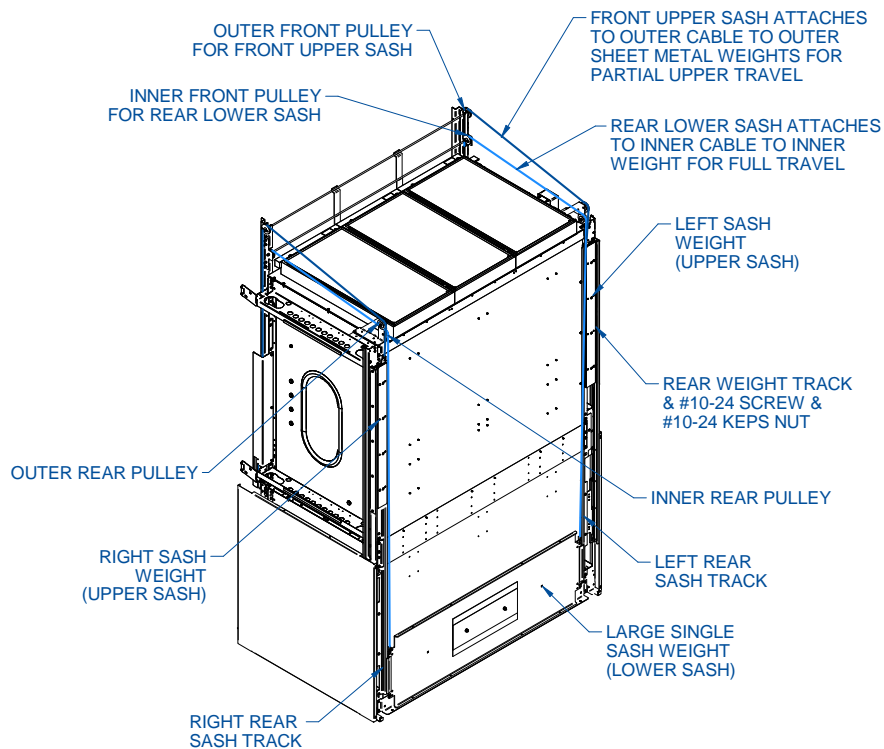

## Sash Stops

Install the four rubber bumpers with #6 screws supplied. One set of rubber bumpers prevents the front upper sash from traveling too low. The second set of rubber bumpers prevent the rear lower sash from touching the floor and provides a good sweep of clean air across the floor. See Figure E-3.

## Corner Post Installation

Locate the left and right corner posts on the third shipping skid. The edges on the corner posts fit directly onto the side frames. The front inner edge of both corner posts

are held in place by stainless steel machine screws. The outer back edge of both corner posts are held in place with steel self-drilling screws. The screws are included in the filtered hood packet. See Figure E-3. Now reinstall the side panels of the lower base.

**Figure E-3**

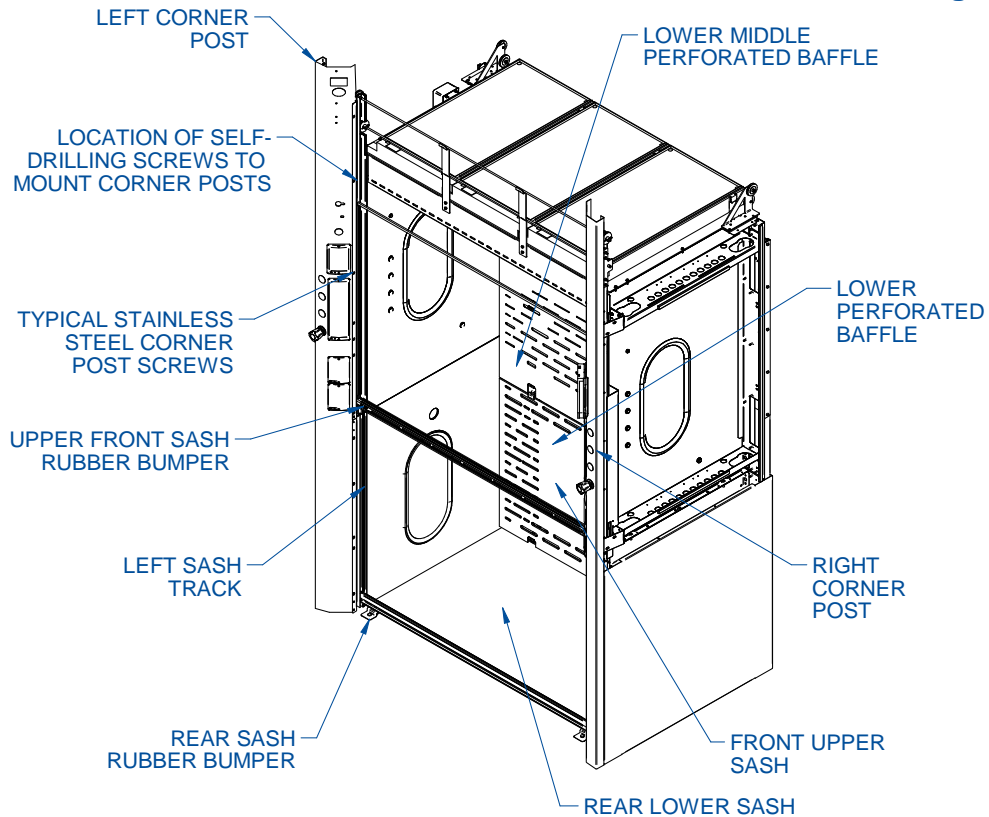

## Wiring

Take the cable included in the filtered hood packet and connect the command module in the back port to the closest connection of the base frame. See [Appendix C: Specifications](#) for a wiring diagram.

**Figure E-4**

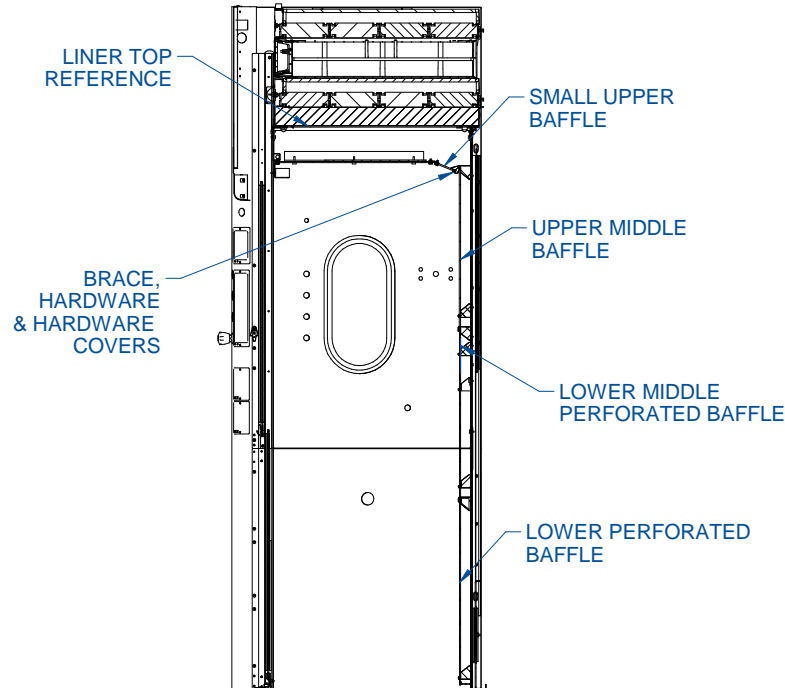

### Baffle Installation

Be sure the baffles are resting in the proper baffle mount supports. The upper baffles require a small baffle connected to a large baffle via a brace, hardware, and hardware covers. See Figures E-3 and E-4 for installation location of each baffle size.

### Header Installation

Locate the header in protective packaging on the third skid. To install, the header is fastened to the corner covers by four #12 screws. From behind the corner posts on the side and install the screws to support the header. See Figure E-5. Now reinstall the side panels of the upper cabinet.

### Filter Installation

See [Section 4: Installation](#) where filter installation is detailed for this step. For easier installation, remove bracket(s) in front of the shafts with a nut driver before installing filters. Replace brackets once the filters are connected prior to operating the filtered hood.

### Front Panel Installation

To install the front panel, hang the two plastic cylinders on the top of the front panel over the corner posts. The bottom of the front panel will then slip behind the header once it has been properly secured at the top. See Figure E-5.

Figure E-5

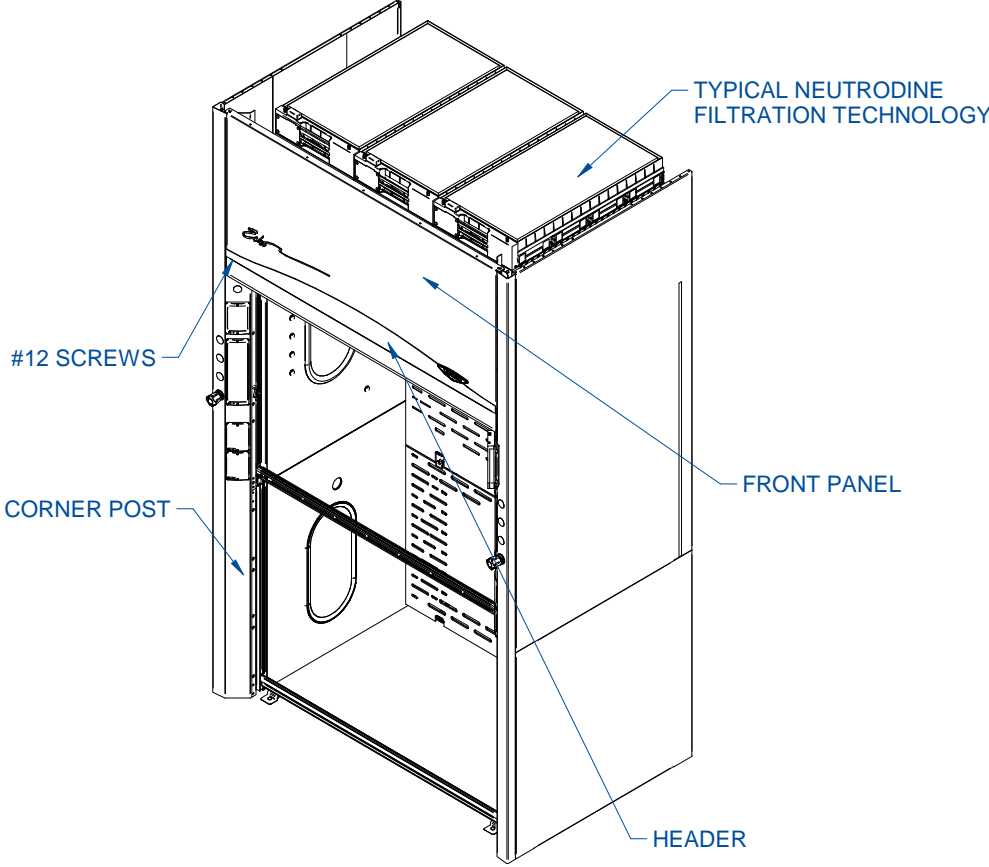

## Appendix F: Approved Chemicals

---

List of approved chemicals for GreenFumeHood® Technology (GFHT) with proprietary Neutrodine® Filtration.

More information on the approved chemical long list can be found online through Erlab. Get to the pdf on a computer by clicking [here](#). If the embedded link did not work, follow these steps:

1. Go to [Erlab.com](#)
2. Hover your mouse on the **[Resources]** tab
3. Now find a section called LIBRARY
4. Click **[Chemical Listing GFH]** under the LIBRARY section.

### The Short List of Chemicals Not Recommended

#### **Gaseous chemicals:**

In normal temperature and pressure conditions with very low boiling point (25°C, 1 Atmosphere). The following are examples:

- Hydrogen (H<sub>2</sub>)
- Helium & noble gases
- Methane
- Ethane
- Ethylene oxide
- Carbon monoxide
- Carbon dioxide
- Nitrogen monoxide
- Propylene
- Propyne
- Acetylene

#### **Organophosphorus compounds:**

Because of their very high toxicity (compounds that can be used as Chemical weapons).

#### **Mercury:**

In spite of the fact that this product is very well retained by Neutrodine, it remains extremely toxic (TLV = 0,05 ppm) and very hard to detect.

#### **Hydrogen Cyanide:**

Immediately lethal

This edition of the GreenFumeHood® Chemical Guide 2019 has been developed by Erlab® R&D laboratory, worldwide leader in filtration technologies for filtered hoods.

This guide is the result of 50 years of research and development into filtration technologies and demonstrates the expertise of Erlab's® R&D laboratory in the field of molecular and particulate filtration.

This booklet is delivered with every filtered hood equipped with GreenFumeHood® technologies and includes a list of chemicals certified by Erlab® dfs S.A.S. for handling under the conditions described by the new AFNOR NF X 15 211: 2009 standard.

Ensure you have the latest copy of this Chemical Guide. Do not hesitate to contact our green partners for the study linked to the Neutrodine® technology lifecycle.



**Please contact Erlab® for information regarding handling of any chemicals which are not listed in this guide.**

# Appendix G: Acid/Formaldehyde Sensor Locations

Fan boxes that have acid or formaldehyde sensors will be labeled with small 'A' or 'F' stickers in the bottom left corner of the fan face and the carton it shipped in. The installment locations for the sensors will be as follows:

Figure G-1

- Key:**
- S** = Solvent Sensor (standard on all Fan Modules)
  - A** = Acid Sensor (optional)
  - F** = Formaldehyde Sensor (optional)
  - T** = Temp Sensor (standard on all Base Frames)
  - H** = Relative Humidity Sensor (standard on all Base Frames)

- Notes:**
- 1) 3-foot GFH: This filtered hood supports a max of (2) chemical sensors. Available configurations are: S only, S + A, or S + F
  - 2) 4-foot GFH: If both Molecode A and Molecode F are recommended, Molecode A would be installed on column 2 and Molecode F on column 1.
  - 3) 5-foot GFH: If both Molecode A and Molecode F are recommended, Molecode A would be installed on column 3 and Molecode F on column 2.
  - 4) 6-foot GFH: If both Molecode A and Molecode F are recommended, Molecode A would be installed on column 3 and Molecode F on column 2.
  - 5) 8-foot GFH: If both Molecode A and Molecode F are recommended, Molecode A would be installed on column 4 and Molecode F on column 3.

\*Molecode S cell replacement for maintenance every 5 years

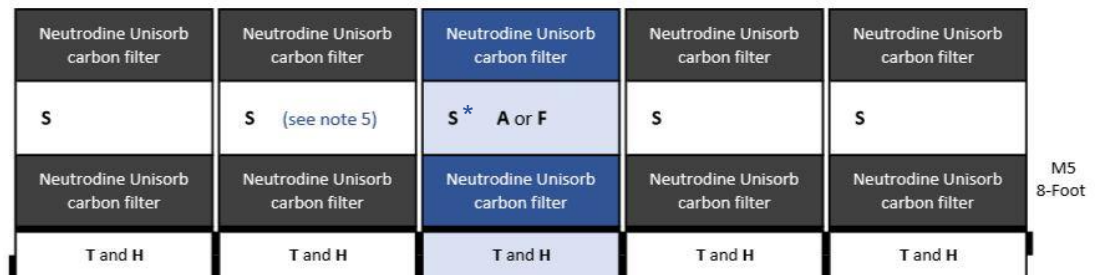
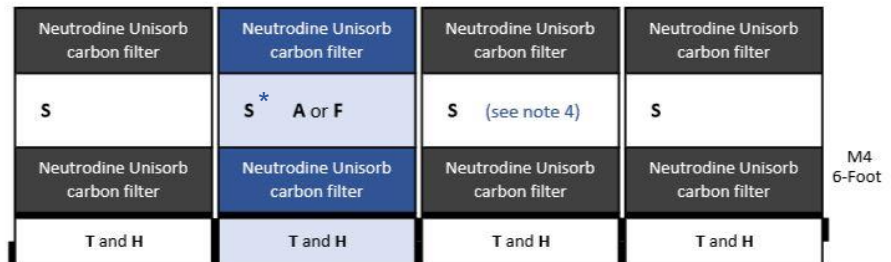
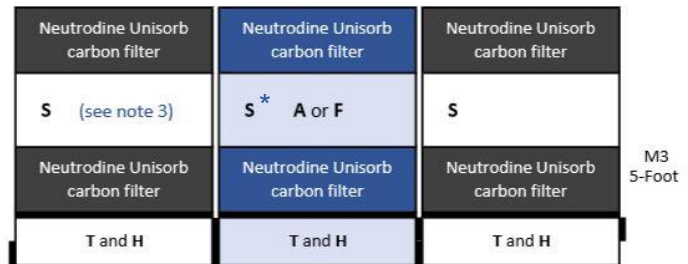
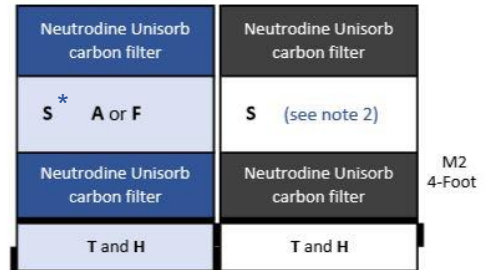
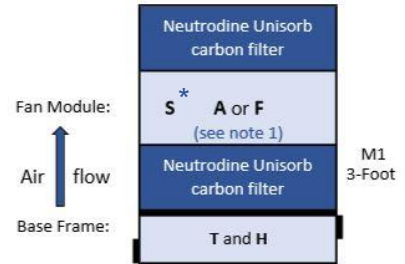

## Appendix H: Low Clearance AFS Replacement

The anemometer or airflow sensor (AFS) is found on the left wall (or right on 3 FT 31.7-inch depth Protector® Airo™) of the filtered hood. When no longer operating correctly, it will need to be replaced. Instructions on how to replace the sensor when there is enough clearance to remove the side panel can be found in Section 8: Maintaining Your Filtered Hood. If the side panel cannot be removed, follow the instructions below:



The following tools are required to replace the equipment:

- Phillips screwdriver
- 5/16-inch nut driver or wrench
- Possibly a flashlight

1. Disconnect the filtered hood from power.
2. Access the airflow sensor. If servicing a unit with side glass, see Step 2a. If servicing a unit with glass, see Step 2b.
  - 2a. If servicing a unit with side glass, uncap the screw covers and remove the 4 screws shown in Figure H-1 with a phillips head screwdriver. Save this hardware. Pull the liner/sensor assembly straight out carefully.

Figure H-1

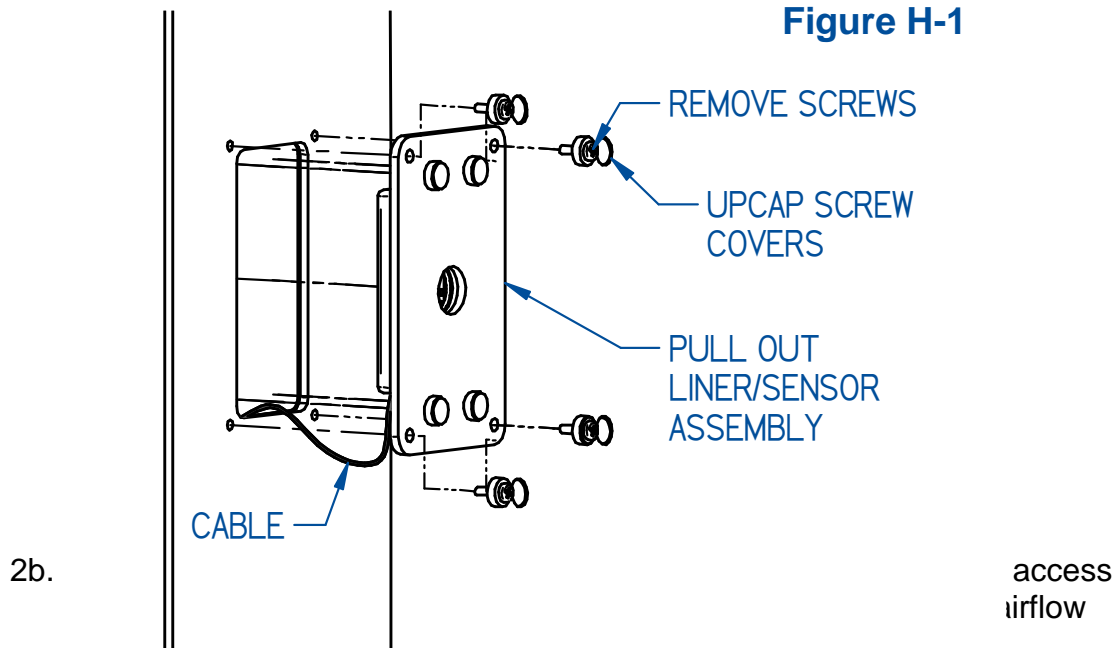

3. Unplug the cable from the airflow sensor housing and leave the loose end in an easily accessible location for re-installation.

4. Locate the nuts holding the airflow sensor secure to the interior wall of the filtered hood (or the recently removed liner/sensor assembly) as shown in Figure 8-24 in Detail A. Loosen and remove the 4 nuts with a 5/16-inch nut driver or wrench. Save this hardware.
5. With the airflow sensor free, remove and dispose of it in an appropriate manner.
6. Install the new airflow sensor onto the studs of the screws as shown in Figure 8-24 in Detail A and reinstall the nuts removed in Step 4.
7. Locate the cable removed in Step 3 and plug it into the new airflow sensor.
8. Reconnect the filtered hood to power. If in alarm, check eGuard for explanation. If in alarm, check eGuard for the explanation. If eGuard says the sensor has been replaced, press the **[mute]** button on the command module. If the alarm is anything other than a replaced message, disconnect the power, re-check all electrical connections and try again.
9. When properly working, reinstall the gasket and panel or liner/sensor assembly that was removed previously by reversing the instructions in Step 2.
10. Recalibrate the airflow sensor by the following the steps in [Section 4: Calibrating the airflow sensor](#).