



**LABCONCO CORPORATION** 8811 Prospect Ave, Kansas City, MO 64132 (816) 333-8811  
or (800) 821-5525 • (816) 363-0130 fax • labconco.com

## **Quick Start Installation Guide for CentriVap® Concentrators and Cold Traps**

### **Preparations**

Do not discard packaging until you have identified all parts that were shipped, and the products operate properly.

### **Safety Precautions**

The following safety precautions must be followed by all personnel unpacking the equipment.

- Wear safety glasses and Wear gloves
- No loose-fitting clothes
- Wear close-toed shoes
- The packaging allows for lifting with a mechanical lift truck or hand truck. If you must lift the equipment manually, use at least two (2) persons and follow safe lifting guidelines.

### **Packaging**

- Unit ships on runners/skid – weight varies 124 lbs. to 164 lbs.
- Accessories will be in boxes – up to 74 lbs.

## **Requirements**

### **Tools & Equipment**

- Box knife
- Flat-blade screwdriver
- 5/16" nut driver
- Mechanical lift truck or hand truck

### **Labor**

- 2 people

### **Location**

- Flat surface space to accommodate each components footprint.
- A fume hood will be required if hazardous solvents will be used in the concentrator.

## Electrical

- Frequency must agree with the serial tag rating. Improper frequency will damage the compressor.
- **Dedicated** single phase circuit Additional appliances on the same circuit may cause the current to exceed the rating of the circuit breaker or fuse.

Serial tags to reflect the following information for the Standard Centrivap					
MODEL	CATALOG NO.	VOLTS	PHASE	CYCLE	AMPS
8501000,-4, -8	8510100,8511100,8512100	115	1	60	13A(5A+8A MAX PUMP)
8501001,-5, -9	8510110,-15,-30,-40,-50,-70,-80,-90 8511110,-15,-30,-40,-50,-70,-80,-90 8512110,-15,-30,-40,-50,-70,-80,-90	230	1	50/60	7A(2.5A+4.5A MAX PUMP)
8501002,-6,-10	8510200,-15,-30,-40,-50,-70,-80,-90 8511200,-15,-30,-40,-50,-70,-80,-90 8512200,-15,-30,-40,-50,-70,-80,-90	115	1	60	15A(7.5A+8A MAX PUMP)
8501003,-7,-11	8510210,-15,-30,-40,-50,-70,-80,-90 8511210,-15,-30,-40,-50,-70,-80,-90 8512210,-15,-30,-40,-50,-70,-80,-90	230	1	50/60	8.25A(3.75A+4.5A MAX PUMP)
Serial tags to reflect the following information for the DNA Centrivap					
MODEL	CATALOG NO.	VOLTS	PHASE	CYCLE	AMPS
8501100,-4	8530100,8511100	115	1	60	13.10A(5.10A+8A MAX PUMP)
8501101,-5	8530110,-15,-30,-40,-50,-70,-80,-90 8531110,-15,-30,-40,-50,-70,-80,-90	230	1	50/60	7.75A(3.25A+4.5A MAX PUMP)
Serial tags to reflect the following information for the Refrigerated Centrivap					
MODEL	CATALOG NO.	VOLTS	PHASE	CYCLE	AMPS
8501200,-4, -8	8520100,8521100,8522100	115	1	60	15.25A(7.25A+8A MAX PUMP)
8501201,-4, -7	8520110, 8521110,8522110	230	1	60	8.1A(3.6A+4.5A MAX PUMP)
8501202,-5, -6	8520115,-30,-40,-50,-70,-80,-90 8521115,-30,-40,-50,-70,-80,-90 8522115,-30,-40,-50,-70,-80,-90	230	1	50	8.1A(3.6A+4.5A MAX PUMP)

## Unpackaging

Have customer inspect packages before unpackaging.

- Document any damage by taking 4 photos of the package before unpackaging.
- Unpack CentriVap and thoroughly inspect it for damage that may have occurred in transit.
  - If there is damage, notify the customer immediately and retain the entire shipment intact for inspection by the carrier. The United States Interstate Commerce Commission rules require that claims be filed with the delivery carrier within fifteen (15) days of delivery.
- Do not discard the carton or packing material for the CentriVap until you have checked all the components and installed and tested the CentriVap.

## Installation

Position the CentriVap Concentrator(Standard or Refrigerated), Cold Trap and the vacuum pump on the benchtop maintaining the order shown below in Diagram 1. A minimum of 3" should be allowed between the sides of the Cold Trap and the adjacent wall surfaces. Restriction of the airflow during operation could adversely affect performance.

- Refer to vacuum pump set up instructions in appendix for the specific type of vacuum pump.

Diagram #1

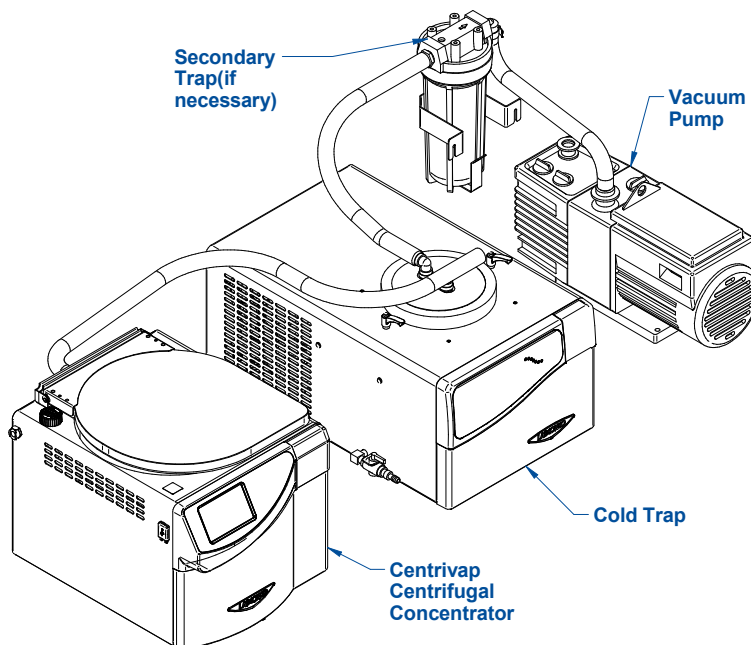

- Join components together using the hoses provided. Hoses will be secured to CentriVap component connections with clamps provided. Use 5/16" nut driver to tighten clamps.
  - Attach one hose to the tube that extends out the back of the Concentrator.
  - Attach the other end of this hose to one of the barb fittings on the Cold Trap Cover Assembly.
  - Attach another hose to the remaining barb fitting on the Cold Trap Cover.
  - If the accessory Secondary Trap is not used, attach the other end of the hose to the inlet port on the vacuum pump.
  - If the accessory Secondary Trap is used, set up the Secondary Trap as explained in the appendix. After secondary Trap is set up, connect the hose from the Cold Trap Cover to the "out" connector on the Secondary Trap and clamp securely. Attach another hose from the remaining connector on the Secondary Trap to the inlet port on the vacuum pump.

## Electrical Connections

- The vacuum pump is powered through the CentriVap's controls(Standard or Refrigerated only). After connecting the electrical cord into the vacuum pump, connect the reverse IEC plug into the back of the Concentrator. If the vacuum

pumps electrical cord is not equipped with a reverse IEC plug, attach a reverse



Reverse IEC

IEC connector to the power cord of the vacuum pump so it can plug into the back of the concentrator.

- Plug the CentriVap Concentrator and Cold Tap into the wall electrical outlets, ensuring they match the rating on the labels.

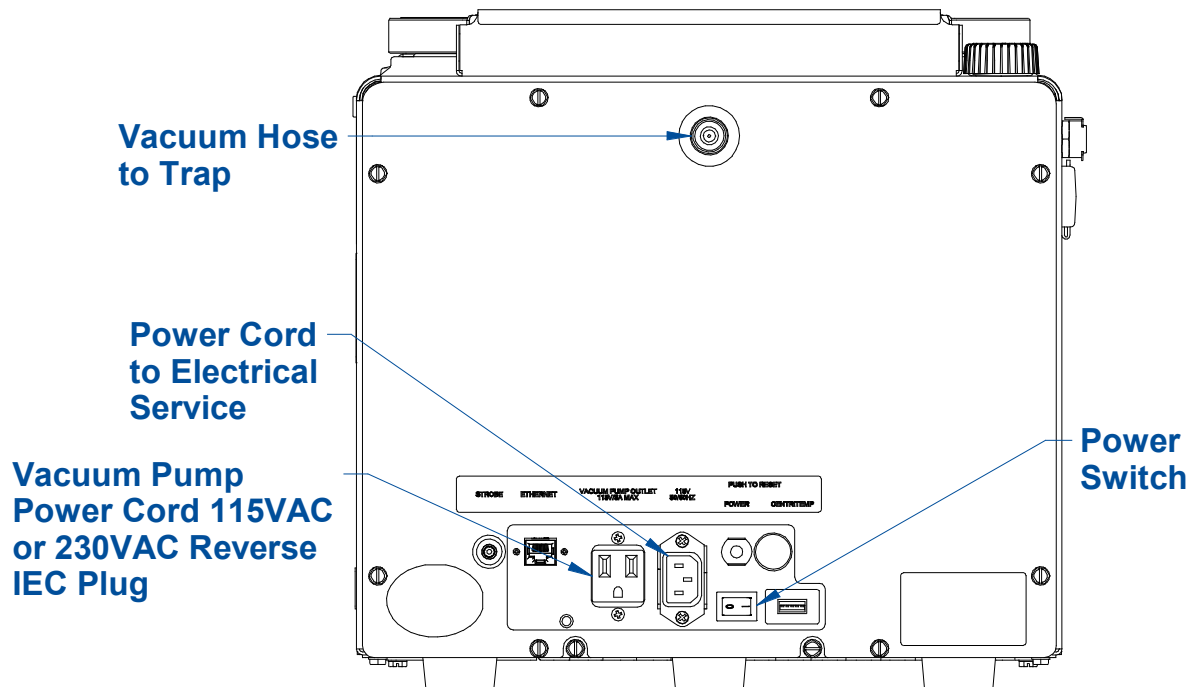

## Testing

- Turn the CentriVap Concentrator power switch ON.
- Close the lid on the CentriVap Concentrator.
- Close the lid on the Cold Trap (if equipped)
- Choose a method and press the Play button on the CentriVap Concentrator.
- Once the CentriVap attains speed the vacuum pump will start automatically.
- To stop the CentriVap Concentrator press the Stop button.
- If the CentriVap Concentrator or Cold Trap fails to perform as expected, consult the User's Manual for troubleshooting or call Labconco at 1-800-821-5525.

## Appendix A. Vacuum Pump Set Up

It is important that the end user carefully reviews the Vacuum Pump User's Manual for warnings, precautions, and operating instructions. Vacuum pumps can be permanently damaged if proper operating conditions and maintenance requirements are not met.

### Diaphragm Vacuum Pump Set Up

- Check the power source and the pump's rating plate to be sure that the power source and the equipment match in voltage, phase and frequency.
- **Pumps with dual voltage motor:** Check that the voltage selection switch at the terminal box is positioned correctly. NOTE: If the pump is switched on the wrong voltage selection, the vacuum pump may be damaged. **Change the selection at the voltage selection switch only if the pump is unplugged from the power source.**

**Voltage selection switch:**

- 1. Disconnect the electrical power cord.**
- Use a screw driver to adjust the **voltage selection switch** at the terminal box of the pump to the supply voltage:  
"115" corresponds to 90-126 V and  
"230" corresponds to 180-253 V.

 voltage selection switch



### Rotary Vane Pump Set Up

- Remove protective caps from inlet and outlet ports.
- Install Inlet Hose Barb
  - Place the centering ring with filter screen on the inlet fitting.
  - Place the hose barb fitting on top of the centering ring.
  - Secure the fitting with the clamp.

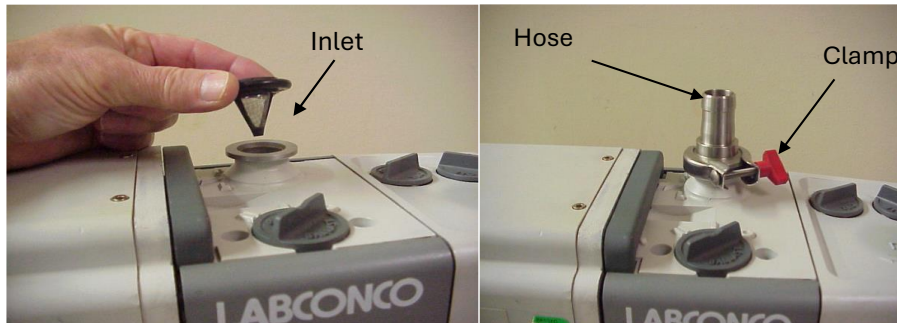

- Install Exhaust Filter
  - NOTE: Rotary vane vacuum pumps must have an exhaust filter to prevent oil mist from exiting the pump and depleting the oil supply.
  - On rotary vane pumps only, attach the exhaust filter to the exhaust port. Insert filters and centering rings if present.
  - Place clamp and secure Exhaust Filter housing to exhaust fitting.



- Open the cap labeled oil and fill the pump with oil until the oil level is between the lines on the sight gauge on the end of the pump housing.
- Verify that the vacuum pump voltage setting agrees with the Concentrator voltage shown on the serial number label.
- Set the gas ballast to closed or minimum position.



## Appendix B. Secondary Trap Set Up

Secondary Chemical Traps minimize the exhausting of solvents into the atmosphere.

- Remove the two small plastic hole plugs.
- Attach the bracket to the side of the Cold Trap housing using the screws provided.
- Attach and securely clamp the hose from the Cold Trap Lid Assembly to the “out” connector of the canister housing.
- Connect and securely clamp another hose from the remaining fitting on the Secondary Trap to the inlet port on the vacuum pump.
- Unscrew the clear bowl of the canister housing from the head.
- Remove both the upper and lower caps from the filter cartridge and insert the small end of the cartridge into the hole in the center of the head.
- Reinstall the clear bowl.



This Quick Start Installation Guide may not provide all the information necessary for your particular vacuum pump installation. For further details including user's manuals and installation videos, scan the QR code or click [here](#).

