



Please read user's manual before
operating equipment

Original Instructions

LABCONCO CORPORATION

8811 Prospect Avenue
Kansas City, MO 64132
(800) 821-5525 | +1 (816) 333-8811
labconco.com

User's Manual

Cell Logic[®] Type B2 Biosafety Cabinets



Register this product

Cell Logic® Type B2 Biosafety Cabinets

2024—Present

32348xxx2	33348xxx2	34348xxx2
32368xxx2	33368xxx2	34368xxx2

Copyright © 2024 Labconco Corporation. The information contained in this manual and the accompanying products are copyrighted and all rights reserved by Labconco Corporation. Labconco Corporation reserves the right to make periodic design changes without obligation to notify any person or entity of such change.

Warranty

Labconco Corporation provides a warranty to the original buyer for the repair or replacement of parts and reasonable labor as a result of normal and proper use of the equipment with compatible chemicals. Broken glassware and maintenance items, such as filters, gaskets, light bulbs, finishes and lubrication are not warranted. Excluded from warranty are products with improper installation, erratic electrical or utility supply, unauthorized repair, use with incompatible chemicals, or non-factory modifications to the original product.

Cell Logic® BioCell Logical Safety Cabinets carry a six-year warranty from date of installation or seven years from date of shipment from Labconco, whichever is sooner. Warranty is non-transferable and only applies to the owner (organization) of record.

Buyer is exclusively responsible for the set-up, installation, verification, decontamination or calibration of equipment. This limited warranty covers parts and labor, but not transportation and insurance charges. If the failure is determined to be covered under this warranty, the dealer or Labconco Corporation will authorize repair or replacement of all defective parts to restore the unit to operation. Repairs may be completed by 3rd party service agents approved by Labconco Corporation. Labconco Corporation reserves the rights to limit this warranty based on a service agent's travel, working hours, the site's entry restrictions and unobstructed access to serviceable components of the product.

Under no circumstances shall Labconco Corporation be liable for indirect, consequential, or special damages of any kind. This warranty is exclusive and in lieu of all other warranties whether oral, or implied.

Returned or Damaged Goods

Do not return goods without the prior authorization from Labconco. Unauthorized returns will not be accepted. If your shipment was damaged in transit, you must file a claim directly with the freight carrier. Labconco Corporation and its dealers are not responsible for shipping damages.

The United States Interstate Commerce Commission rules require that claims be filed with the delivery carrier within **fifteen (15) days** of delivery.

Limitation of Liability

The disposal and/or emission of substances used in connection with this equipment may be governed by various federal, state, or local regulations. All users of this equipment are required to become familiar with any regulations that apply in the user's area concerning the dumping of waste materials in or upon water, land, or air and to comply with such regulations. Labconco Corporation is held harmless with respect to user's compliance with such regulations.

For additional questions or support:

Labconco Customer Care +1 (816) 333-8811

Labconco Technical Support (800) 821-5525

Hours 7:30 a.m.-5:30 p.m. CST

**Part #4028941 Rev. A
ECO P392**

Table of Contents

1: INTRODUCTION	9
About This Manual	9
Contents Included	9
2: BEFORE YOU INSTALL	10
Location Requirements	10
Clearance Requirements	11
Electrical Requirements	11
Service Line Requirements	11
Exhaust Requirements	12
Air-Tight Damper	13
User-Supplied Microscope Requirements – Scope-Ready™ Package Only	14
User-Supplied Circulator Requirements – Temp-Zone™ Package Only	15
3: SAFETY PRECAUTIONS	16
Typographical Conventions	16
General Safety Precautions	18
Safety Precautions for this Product	20
4: INSTALLATION	22
Unpacking	22
Electrical Connection	27
Ethernet Connection	28
Service Line Connection	29
Drain Valve Installation (Optional)	30

Exhaust Connection	31
Microscope Installation (optional)	32
Circulator Installation (optional)	34
Certification	36

5: PERFORMANCE FEATURES 37

Laminar Airflow	37
Directional Airflow	38
Cabinet Air Intake (Front Grille)	38
HEPA Filters	39
ULPA Filters	39
Motor/Blower	40
Airflow Sensor	40
UV Lamp (optional)	41
Scope-Ready™ Package (optional)	41
Pure-Vu™ Seal	41
Stand-Still™ Isolation Platform	42
Temp-Zone™ Package (optional)	42

6: CELL LOGIC TYPE B2 OPERATING SYSTEM 43

Home Screen	43
Display Sleep Mode	44
Keypad	44
Navigating the Data Logs Menu	45
Navigating the Settings Menu	47
Configuration Submenu	47
Adjusting Sound	49
Selecting a Language	50
Setting the Clock	50
Selecting the Units of Measure	51
Activating the Security Lock	51
Setting the Data Acquisition Rate	51

Adjusting the Display	51
Utilizing Network Connection	52
Activating Email Alerts	52
Adjusting Maintenance Reminders	54
The Certification Submenu	55
Navigating the Help Menu	55
About	56
Software Update via USB Thumbdrive	57
Software Update via the Ethernet	57
Automatic Update Notification	57
Sensors	58
Diagnostics	59
Resources	59
Notifications	60
Timer Operation (Optional)	60
Alerts	61
Airflow Blockage	61
Resetting the Airflow Blockage Alert System	62
Exhaust Airflow Check	62
Alarms	62
Power Loss Alarm	63
Sash Height Alarm	63
Memory Failure	64
Blower Failure Alarm	64
Exhaust Failure Alarm	65
7: USING YOUR CELL LOGIC TYPE B2	66
Feature Overview	66
System Reset Switch	67
Keypad	68
Sash Operation	69
Blower Operation	69
Light Operation	69
Outlet Operation	69
Vacu-Pass™ Cord & Cable Portal (optional)	70
Working in the Cabinet	71
Planning	71

Cabinet Start-up	71
Wipe Down	72
Loading Materials and Equipment	72
Work Techniques	72
Final Purging	72
Unloading Materials and Equipment	72
Wipe Down	72
Shutdown	73

8: MAINTAINING YOUR CELL LOGIC TYPE B2 **74**

Maintenance Safety Precautions	74
---------------------------------------	-----------

Recommended Maintenance Schedule	75
---	-----------

Service Operations	76
---------------------------	-----------

Resetting a Circuit Breaker	76
Cleaning Beneath Dished Work Surface (Temp-Zone™ Only)	77
Cleaning Beneath Dished Work Surface (Scope-Ready™ Only)	78
Front Grille Removal	79
Front Panel Removal	79
Changing the LED Lamps	80
Changing the Optional UV Lamp	82
Towel Catch Removal	82
Storage	83

9: ACCESSORIES **85**

IV Bar	85
---------------	-----------

Stand-Still™ Isolation Platform	85
--	-----------

Telescoping Base Stands (Non-Welded)	86
---	-----------

Telescoping Base Stands (Welded)	86
---	-----------

Electric Hydraulic Lift Base Stands (with Leveling Feet)	86
---	-----------

Electric Hydraulic Lift Base Stands (with Casters)	87
---	-----------

Pure-VU™ Seals	87
-----------------------	-----------

10: TROUBLESHOOTING **88**

Blower and Lights not working	88
--------------------------------------	-----------

Blower only will not start	89
-----------------------------------	-----------

Lights only will not illuminate	90
UV Light will not illuminate	91
Airflow Alert activating	92
Filter Life Gauge not at 100% when new	93
Contamination in the work area	94
Exhaust Alarm activates 60 seconds after turning blower ON	95
APPENDIX A: PARTS LIST	96
APPENDIX B: DIMENSIONS	97
APPENDIX C: SPECIFICATIONS	98
Power Data	98
Motor Specifications	98
Environmental Conditions	99
APPENDIX D: QUICK CHART REFERENCE	100
APPENDIX E: INSTALLATION GUIDE: PURE-VU™ SEAL AND STAND-STILL™ ISOLATION PLATFORMS	101
Pure-Vu™ Template	108

1: Introduction

Congratulations on the purchase of a Cell Logic® Type B2 biosafety cabinet. The biosafety cabinet is designed to protect you, the product and the laboratory environment from biohazardous aerosols. It is the result of years of experience in manufacturing laboratory equipment, and users like you suggested many of its features to us.

This biosafety cabinet offers many unique features. To take full advantage of them, please acquaint yourself with this manual and keep it handy for future reference.

About This Manual

This manual is written for the installer and user of this product. For detailed service, certification, or technical information, please utilize the Technical Manual located on the website labconco.com.



This manual contains important operation and safety information. When you see a symbol, such as the INFO symbol to the left, pay close attention to the information provided. Before installing or operating this product, you must read [Section 3: Safety Precautions](#).

Contents Included

The following items are packaged with the product.

- User's manual thumb drive
- Drain valve assembly and fasteners
- Power cord
- Support Bolt with Locking Nut (see installation instructions for Stand if ordered).
- Punch Kit (for Scope-Ready Packages Only)
- Pure-Vu™ Seal (for Scope-Ready Packages Only)
- XL Pure-Vu™ Seal (for Scope-Ready Packages Only)

The location of these items and additional details are found in [Section 4: Installation](#).

2: Before You Install

Before you install the product, the site should be prepared for installation. Examine the location where you intend to install it. You must be certain that the area is level and of solid construction. In addition, a dedicated source of electrical power must be located within 10 feet (3 m) of the installation site for the included power cord, or maximum of 25 feet (7.5m) to utilize a longer (user-supplied), appropriately rated power cord.

Location Requirements

A biosafety cabinet should be located away from areas of high foot traffic, doors, fans, ventilation registers or vents, chemical fume hoods or other air-handling devices. Any of these may interfere with the airflow patterns in and around the product, and subsequently diminish product and/or personnel protection. All windows in the room should remain closed. Figure 2-1 shows the preferred and alternate locations for this product.

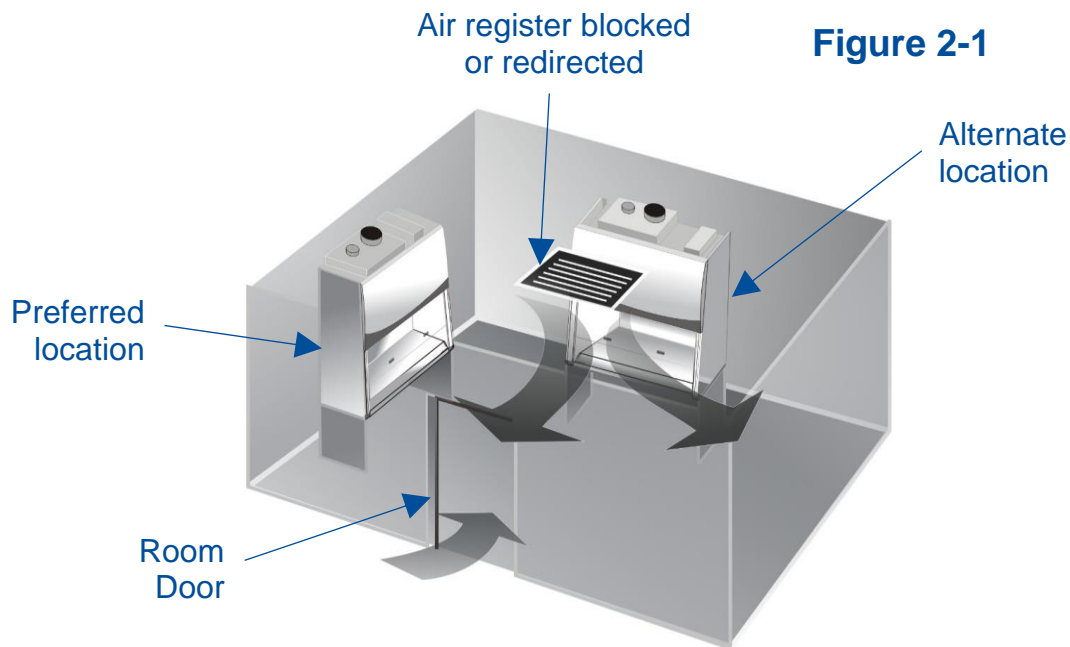

Clearance Requirements

A minimum clearance of at least 6 inches (150 mm) is suggested on the top and both sides of the product for service.

See [Appendix B: Dimensions](#) for overall product dimensions.

Electrical Requirements

The product models have the following electrical requirements.

Catalog Number	Typical Operating Current (Amps)	Electrical Circuit Requirements ¹	
3x348xx02	2 A	115 V, 60 Hz, 12 A	1 Phase
3x348xx22	2 A	100 V, 50/60 Hz, 12 A	1 Phase
3x348xx-12, 32, 42, 52, 62, 72	1 A	230 V, 50/60 Hz, 6 A	1 Phase
3x368xx02	5 A	115 V, 60 Hz, 12 A	1 Phase
3x368xx22	5 A	100 V, 50/60 Hz, 12 A	1 Phase
3x368xx-12, 32, 42, 52, 62, 72	2.5 A	230 V, 50/60 Hz, 6 A	1 Phase

¹ Electrical Requirements, 'V' = VAC (Voltage with alternating current), 'A' = Amperes



A dedicated outlet with an appropriate circuit breaker should be located as close as possible to the product, but no greater than 10 feet (3 m). Consult your local electrical codes for properly rated circuit breakers. For safe operation the dedicated outlet must provide a protective earthing ground connection to the product.



On 100V and 115V models, both internal electrical outlets are protected by a ground fault interrupter circuit (GFI). Labconco does NOT recommend connecting the product's power cord into a GFI outlet. GFI outlets can nuisance trip, resulting in complete removal of power to the product. Such a scenario would result in complete loss of product and/or personnel protection.

Service Line Requirements

All utility service lines should be ¼ inch O.D., brass, copper, or stainless steel, and equipped with an easily accessible shut-off valve. The service valves are rated for operation at 40 PSI (275 kPa). If the service line pressure exceeds this, it must be equipped with a pressure regulator to reduce the line pressure.



Note: The use of flammable gases or solvents should be avoided in the biosafety cabinet. Open flame in the cabinet will disrupt the laminar airflow in the cabinet and may damage the HEPA filters. Flammable gases or solvents may reach explosive concentrations in the cabinet or ductwork. If you feel that the procedure requires the use of an open flame or flammable materials, contact your institution's safety office.



Note: The use of air or gases under high pressure should be avoided as they may seriously disrupt the airflow patterns in the cabinet.

Exhaust Requirements

This product must be connected to a remote (building) exhaust system.



Note: Only connect the biosafety cabinet to a suitable exhaust system that is dedicated to the biosafety cabinet, or dedicated to exhausting laboratory ventilation equipment. Do NOT connect the biosafety cabinet to the building's general HVAC system for room exhaust.

Examine the location to ensure that it accommodates the cabinet's exhaust duct. The area directly above the cabinet's exhaust port should be clear of structural elements, water and utility lines, or other fixed obstructions. There should be enough clearance to accommodate a 10-inch diameter duct. See Figure 2-2.



Figure 2-2

Avoid cabinet locations that require an elbow directly above the cabinet's exhaust connection or an excessive number of elbows in the exhaust system. There should be a straight length 10 duct diameters long between the cabinet connection and any elbow, and between subsequent elbows. See Figure 2-3.

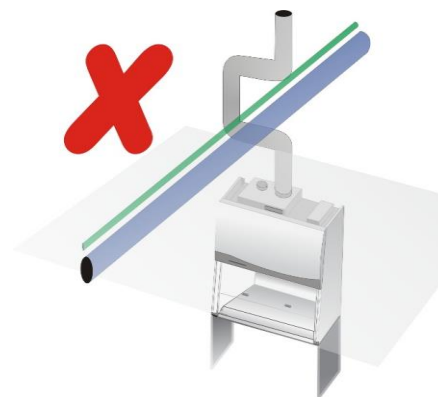

Figure 2-3

The exhaust system must be capable of moving the following volumes of exhaust air at the negative pressures listed. The **Airflow Volumes** are the values recorded via direct measurement using a flow hood on the exhaust duct above the cabinet. The **Concurrent Balance Values** are measured in the exhaust duct via traverse methodology, and will always be higher due to differences in volume measurement methodologies.



NOTE: The **Concurrent Balance Value (CBV)** is established by NSF during listing testing. The Recommended Duct Vacuum listed is measured at the biosafety cabinet’s connection to the exhaust system. The values published include 0.7 inches H₂O of filter loading from the biosafety cabinet’s original pressure. In order to obtain maximum exhaust HEPA filter loading, the system should be capable of generating a static pressure 1.3 inches higher than the **Recommended Duct Vacuum** pressure listed in Table 2-1.

Table 2-1

Cell Logic Type B2 Model	Airflow Volume		Concurrent Balance Value		Recommended Duct Vacuum	
	ft ³ /min	m ³ /hr	ft ³ /min	m ³ /hr	WC ¹	Pa
4-foot, 8" Sash	695	1181	818	1390	1.8	448
6-foot, 8" Sash	1175	1996	1382	2348	2.5	622

1: WC = Inches of Water Column, typically expressed in units of *inches H₂O*.



NOTE: The facility’s remote blower cannot run at its nominal flow rate with the sash completely closed. If the sash must be closed completely to utilize the internal UV Light (optional), then the facility’s remote blower must be shut off or its flow rate reduced by 90% or more for proper operation of the biosafety cabinet. The Cell Logic B2 biosafety cabinet includes a Remote Communication Board that contains dry relay contacts which can be configured to signal the facility’s remote blower to turn on and turn off (or reduce speed). For further information, contact Labconco’s Product Service Department or refer to the Logic Technical Manual. A remote electrical switch to control the facility’s remote blower can also be installed near the biosafety cabinet for manual control of the remote blower.

Air-Tight Damper

The exhaust housing on a Type B2 biosafety cabinet is sealed to the top of the biosafety cabinet. All the cabinet’s airflow is exhausted through the exhaust housing by the facility’s remote blower. The Cell Logic Type B2 biosafety cabinet includes an air-tight damper as an integral part of the exhaust housing. See Figure 2-4.

The air-tight damper allows for fine adjustment of the exhaust air volume provided, to correctly set the necessary exhaust airflow for each biosafety cabinet. It also allows the biosafety cabinet to be sealed off from the building exhaust system, should it become necessary to do so.

Figure 2-4

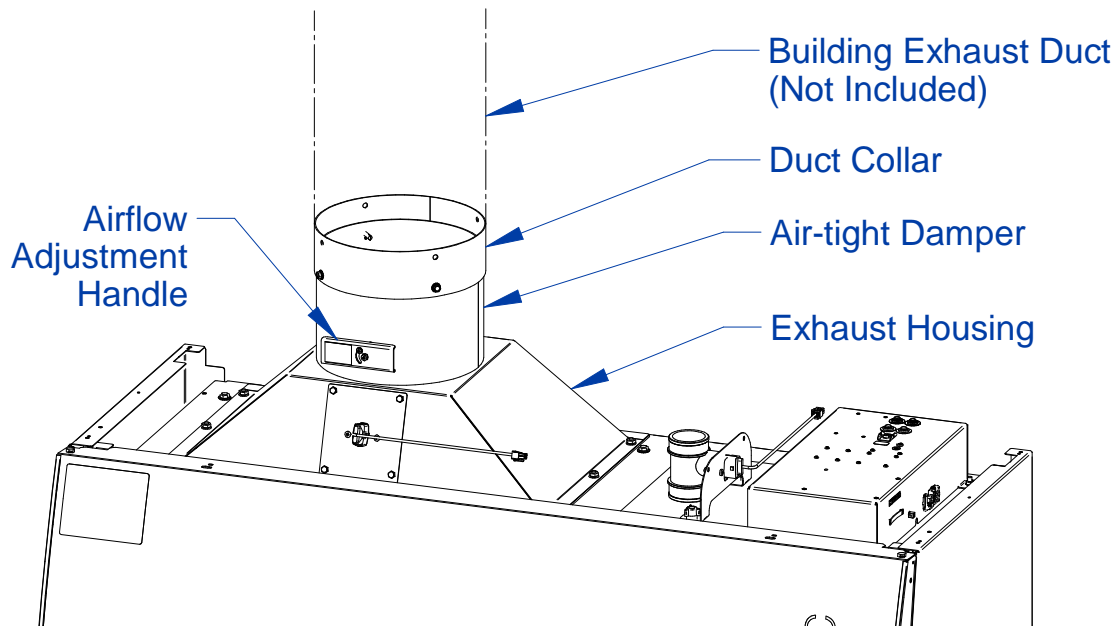

Visual appearance of biosafety cabinet and exhaust connection may vary by model.

User-Supplied Microscope Requirements – Scope-Ready™ Package Only

If installing a microscope, locate the Stand-Still™ Isolation Platform in a separate box shipped with the cabinet. The Stand-Still Isolation Platform supports the microscope on top of the stainless steel work surface to eliminate up to 94% of vibrations and to promote safe airflow. If using a stereoscope with a forward extending base, the extended Stand-Still XL Isolation Platform should be ordered from [Section 9: Accessories](#). Figures from [Appendix E](#) should be used to assist your set-up.

On models with the Scope-Ready package, the Cell Logic Biosafety Cabinet includes a clear, disposable Pure-Vu™ Seal that can be altered to accommodate most microscope's eyepieces. Utilize the Punch Kit (Catalog Number 4027801), supplied with your cabinet, to cut the two eyepiece holes at approximately 2.75" (69.9 mm) spacing to match the height of your scope. As a convenience, pre-cut Pure-Vu eyepiece seals can be ordered from [Section 9: Accessories](#). The pre-cut accessory Pure-Vu Seals are based off the nominal height from the base of the microscope to eyepiece centerline and can save time modifying the seal shipped with the Cell Logic. If using a stereoscope with a forward extending base, one of the Pure-Vu XL Seals should be ordered from

[Section 9: Accessories](#). Figures from [Appendix E](#) should be used to assist your set-up for all Pure-Vu Seals.

User-Supplied Circulator Requirements – Temp-Zone™ Package Only

The Temp Zone™ features a temperature controlled area on the work surface where heated or chilled samples may be transferred and kept at optimum temperature. A user-supplied circulator that continually delivers heated or chilled water at a minimum flow rate of 0.5 GPM (1.9 LPM) with typical volume of 6 liters is required and may be obtained from your laboratory supply dealer.

Quick connection fittings are included on the left side of the cabinet and are sized for 3/8" diameter polyethylene tubing. As a convenience, the following items are included with the Temp-Zone package:

- 20 Feet (6 meters) of 3/8" (9.5 mm) outer diameter tubing
- Insulation for 3/8" outer diameter tubing
- Quick-connect fittings (3/8 tube x 1/8 NPT, 3/8 tube x 1/4 NPT, 3/8 tube x 3/8 NPT)

The above items will allow for connection to a water circulator. The water circulator can be located underneath the cabinet or next to the cabinet on the floor.

3: Safety Precautions

Before unpacking, installing, operating, maintaining, or servicing this equipment, read the following safety warnings and precautions.

Avant le déballage, l'installation, le fonctionnement, l'entretien ou la maintenance de cet équipement, lire les avertissements de sécurité et les précautions d'emploi.



CAUTION – See Manual. When this symbol is on the equipment, it indicates a caution that is detailed in this manual.

MISE EN GARDE – Voir le manuel. Lorsque ce symbole est apposé sur l'équipement, il renvoie à une mise en garde détaillée dans ce manuel.

Typographical Conventions



DANGER – An imminently hazardous situation which, if not avoided, will result in death or serious injury.

DANGER – Situation dangereuse imminente qui, si elle n'est pas évitée, peut entraîner la mort ou des blessures graves.



CAUTION – Indicates a potentially hazardous situation which, if not avoided, may result in minor or moderate injury or damage to property.

MISE EN GARDE – Signale une situation potentiellement dangereuse qui, si elle n'est pas évitée, peut provoquer des blessures mineures à modérées ou des dommages matériels.



NOTE – Advice or suggestions to help the process.

REMARQUE – Conseils ou suggestions pour le déroulement du processus.



BURN RISK (HIGH TEMPERATURE) – Air or components that will be very hot. Take care not to touch these defined areas. Failure to avoid these areas may result in moderate to severe injury.

RISQUE DE BRÛLURE (TEMPÉRATURE ÉLEVÉE) – Air ambiant ou composant devenant très chaud. Veiller à ne pas toucher ces zones délimitées. L'absence de précaution pour éviter ces zones peut entraîner des blessures modérées, voire graves.



EXTREME COLD (LOW TEMPERATURE) – Air or components that will be very COLD. Take care not to touch these defined areas. Failure to avoid these areas may result in moderate to severe injury.

FROID INTENSE (TEMPÉRATURE BASSE) – Air ambiant ou composant devenant très froid. Veiller à ne pas toucher ces zones délimitées. L'absence de précaution pour éviter ces zones peut entraîner des blessures modérées voire graves.



PINCH POINT – Areas or components that can pinch or cut. Take care not to touch these defined areas.

POINT DE PINCEMENT – Zones ou composants présentant un risque de pincement ou de coupure. Veiller à ne pas toucher ces zones délimitées.



MOVING PARTS – Areas or components that contain moving parts. Take care not to touch these defined areas.

PIÈCES MOBILES – Zones ou composants contenant des pièces mobiles. Veiller à ne pas toucher ces zones délimitées.



RISK OF ELECTRICAL SHOCK – The specified procedure or area poses a risk of electrical shock. ALWAYS disconnect main power cord or electrical supply before proceeding.

RISQUE DE CHOC ÉLECTRIQUE – La procédure ou la zone spécifiée présente un risque de choc électrique. TOUJOURS débrancher le cordon d'alimentation secteur ou l'alimentation électrique avant toute intervention.



FLAMMABLE / NO SOLVENTS – Do not place flammable liquids or solvents in this product.

INFLAMMABLE / PAS DE SOLVANTS – Ne placez aucun liquid inflammable dans cette produit.



LIFTING HAZARD – Do not lift or move this equipment without assistance.
DANGER DE LEVAGE – Ne pas soulever ou déplacer cet équipement sans assistance.



MAGNETIC FIELD IN USE – Magnets or magnetic field present.
CHAMP MAGNETIQUE UTILISE – Présence d'aimants ou de champ magnétique.



DO NOT TOUCH – Components or areas indicated are sensitive and will suffer damage if touched. Take care not to touch these defined components or areas. Failure to avoid these areas will result in damage to the product.
NE PAS TOUCHER – Les composants ou les zones indiquées sont sensibles et subiront des dégâts s'ils sont touchés. Veiller à ne pas toucher ces composants ou zones délimité(e)s. L'absence de précaution pour éviter ces zones endommagera le produit.



TOOL REQUIRED – Tool required to access specified area.
OUTIL NÉCESSAIRE – Outil nécessaire pour accéder à la zone spécifiée.

General Safety Precautions

Follow all the safety precautions described in this section.



Before removing any panels which require a tool for removal, ALWAYS disconnect the main power cord or electrical supply. Failure to remove all electrical power before proceeding will result in moderate to serious injury, death, or damage to property.

Avant le retrait d'un panneau nécessitant l'utilisation d'un outil, TOUJOURS débrancher le cordon d'alimentation secteur ou l'alimentation électrique. Le non-respect de la consigne consistant à couper complètement l'alimentation électrique avant toute intervention peut entraîner des blessures graves, la mort ou des dommages matériels.



Never contact moving parts with your person. Failure to avoid moving parts will result in moderate to serious injury, death, or damage to property.

Ne jamais toucher les parties mobiles. Le non-respect de la consigne consistant à éviter les pièces mobiles peut entraîner des blessures graves, la mort ou des dommages matériels.



Never misuse this product. Never disable, override, or otherwise bypass safety guards, panels, switches, sensors or alarms. Doing so will result in moderate to serious injury, death, or damage to this product or property.

Ne jamais utiliser ce produit à mauvais escient. Ne jamais désactiver, annuler ou contourner les capots, panneaux, interrupteurs, capteurs ou alarmes de sécurité. Ceci entraînerait des blessures graves, la mort ou des dommages matériels à ce produit ou à d'autres biens.



If the unit is not operated as specified in this manual it may impair the protection provided by the unit.

Si l'unité n'est pas utilisée comme spécifié dans ce manuel il peut diminuer la protection fournie par l'unité.



Do not position the unit so that it is difficult to operate the main disconnect device.

Ne placez pas l'appareil de sorte qu'il est difficile de faire fonctionner le dispositif principal de déconnexion.



Do not lift or move this equipment without assistance.

Ne pas soulever ou déplacer cet équipement sans assistance.

Safety Precautions for this Product



Electrical outlets in the cabinet are restricted to 5 amps (100-115v) or 3 amps (230v) maximum current.

Prises électriques dans l'armoire sont limitées à 5 (100-115v) o 3 (230v) courant maximum ampères.



Do not use any detachable power cord that is not adequately rated for the unit.

Ne pas utiliser un fil électrique amovible qui n'est pas du tension nominale de l'appareil.

The biosafety cabinet should be certified by a certification technician before its initial use. The cabinet should be recertified whenever it is relocated, serviced or at least annually thereafter. Filter integrity and airflow performance should be verified before using the cabinet.



Some internal components of the biosafety cabinet may become contaminated during operation of the unit. Only experienced personnel competent in decontamination procedures should decontaminate the cabinet before servicing these components. If you have any questions regarding certification agencies, or need assistance in locating one, contact Labconco's Product Service Department at 800-821-5525 or 816-333-8811.

DO NOT load more than 50 lbs. (23 Kg) in the work area. Exceeding this limit may damage the work surface and its supports. Excessive weight in the cabinet may increase the risk of it overturning, or failure of hydraulic lift stands, resulting in the cabinet and stand overturning. If your application requires loading more than 50 lbs., contact Labconco's Product Service Department at 800-821-5525 or 816-333-8811 for assistance.



Avoid the use of flammable gases or solvents in the biosafety cabinet. Care must be taken to ensure against the concentration of flammable or explosive gases or vapors. An open flame should NOT be used in the biosafety cabinet. Open flames will disrupt airflow patterns, burn the HEPA filter and/or damage the filter's adhesive. Gases under high pressure should not be used in the biosafety cabinet, as they may disrupt its airflow patterns.

HEPA filters only remove particulate matter. Operations generating volatile toxic chemicals or radionuclides must be evaluated carefully.



The media of HEPA filters is fragile and should not be touched. Avoid puncturing either HEPA filter during installation or normal operation. If you suspect that a HEPA filter has been damaged, DO NOT use the cabinet; contact a local certification agency or Labconco at 800-821-5525 or 816-333-8811 for re-certification information.

The HEPA filters in the biosafety cabinet will gradually accumulate airborne particulate matter from the room and from work performed in the cabinet. The rate of accumulation will depend upon the cleanliness of the room air, operating time and the nature of work being done in the cabinet. The Filter Gauge accurately displays the amount of filter life remaining.

Proper operation of the cabinet depends largely upon its location and the operator's work habits. Consult [Section 4: Installation](#) and [Section 7: Using Your Cell Logic Type B2](#) for further details.

Avoid direct exposure of plastic or coated materials to ultraviolet (UV) radiation. Never bypass the UV safety interlock that only allows the UV light to work when the sash is closed. When surface disinfecting the biosafety cabinet:

- Avoid splashing the disinfecting solution on skin or clothing.
- Ensure adequate ventilation.
- Carefully follow the disinfectant's safety instructions.
- Always dispose of disinfecting solutions in accordance with local and national laws.
- DO NOT allow disinfectants with high concentrations of free chlorine to contact the stainless steel components of the biosafety cabinet for a long period of time. Free chlorine will corrode stainless steel after extended contact.



Biosafety cabinets should be decontaminated for any of the following reasons:

- Before maintenance work requiring entry into contaminated areas.
- Before HEPA filter changes.
- Before performing certification tests requiring entry into contaminated areas.
- Before relocating the cabinet.
- Before changing research programs.
- After the gross spill of biohazardous material or toxic chemicals.

4: Installation

With the installation site properly prepared, you are ready to unpack and install the equipment. This section covers how to:

- Unpack and move the product
- Install the product
- Connect electrical service
- Connect service utilities
- Connect to an exhaust system
- Arrange certification for the product



A quick reference Installation Guide is located on the front sash glass (see Figure 4-2)

Unpacking



The following tools are required to unpack the equipment:

- Box knife
- #2 Phillips screwdriver
- Two ½” wrenches
- Pliers
- Carpenter’s level



The following safety precautions must be followed by all personnel unpacking the equipment.

- Wear safety glasses
- Wear gloves
- No loose fitting clothes
- Wear close-toed shoes
- Follow safe-lifting practices (do NOT attempt to lift this product without specialized lifting equipment certified to lift up to 1000 lbs.)

Step 1

Carefully remove the outer carton and inspect the product for damage that may have occurred in transit. If the product is damaged, take pictures of the product and the outer packaging, and notify the delivery carrier immediately. Retain the entire shipment, including outer packaging, intact for inspection by the carrier.



Note: United States Interstate Commerce Commission rules require that claims be filed with the delivery carrier within fifteen (15) days of delivery.

Do not return goods without the prior authorization of Labconco. Unauthorized returns will not be accepted.

If the product was damaged in transit, you must file a claim directly with the freight carrier. Labconco Corporation and its dealers are not responsible for shipping damages.

Do not discard the carton or packing material for the product until all of the components have been checked, installed and tested.

The product is secured to the pallet in two places on each side. To access the nuts and bolts holding the product to the pallet, remove the side panels by removing and keeping the two Phillips screws on both panels. Swing the front of each panel away from the cabinet, and lift it straight up to remove the panel from the cabinet. See Figure 4-1.

Figure 4-1

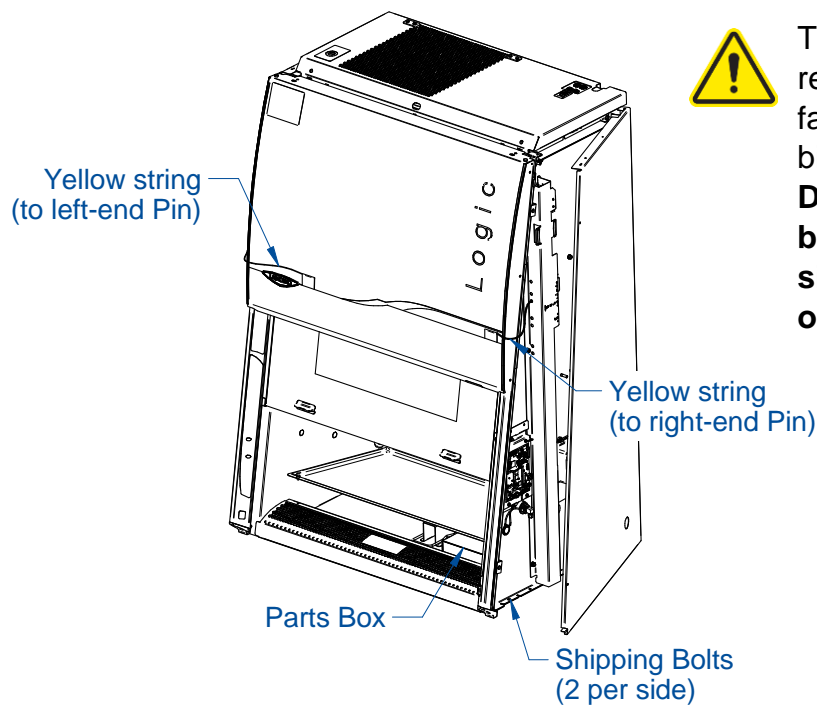

The side panels must be removed to access the fasteners that secure the biosafety cabinet to the pallet. **DO NOT attempt to lift the biosafety cabinet by the side panels; damage will occur.**

Step 2 – Installation on an Existing Work Surface

Move the cabinet, attached to its pallet, by using a floor jack, or a furniture dolly underneath the unit. **DO NOT** move the cabinet by tilting it onto a hand truck.



When lifting the cabinet **DO NOT** lift the cabinet in the middle front area of the hull. Lifting here may bend or distort the bottom of the cabinet, causing damage to the unit.



Note: The cabinet is very top heavy. Use caution when lifting or moving it.

When installing the cabinet onto an existing work surface or benchtop, ensure that the structure can safely support the combined weight of the cabinet and any related equipment. The work surface should be at least as wide as the cabinet and 31 inches (787 mm) deep to properly support the unit. A hole or notch may be cut in the supporting surface in the right front corner to accommodate the optional drain valve.

Step 2 – Installation on a Labconco Base Stand

Move the cabinet, attached to its pallet, by using a floor jack, or a furniture dolly underneath the unit. **DO NOT** move the cabinet by tilting it onto a hand truck.



When lifting the cabinet **DO NOT** lift the cabinet in the middle front area of the hull. Lifting here may bend or distort the bottom of the cabinet, causing damage to the unit.



Note: The cabinet is very top heavy. Use caution when lifting or moving it.

Labconco offers accessory base stands in a variety of configurations to suit your particular needs. If assembly of the base stand is required, the assembly instructions are packaged with the base stand.

Using a mechanical lift, raise the cabinet.

Before setting the cabinet onto the stand, using the four attachment bolts supplied with the stand, align the mounting tab holes on the cabinet with the four holes on the stand's top rail. Drop each bolt through the mounting tab hole and into each hole on the stand's top rail. Carefully lower the cabinet onto the stand. See Figure 4-2.

After the cabinet is in place, remove each attachment bolt, and flip it over to install it up through the stand's top rail, and add the associated washers and nut. Tighten each bolt.

Figure 4-2

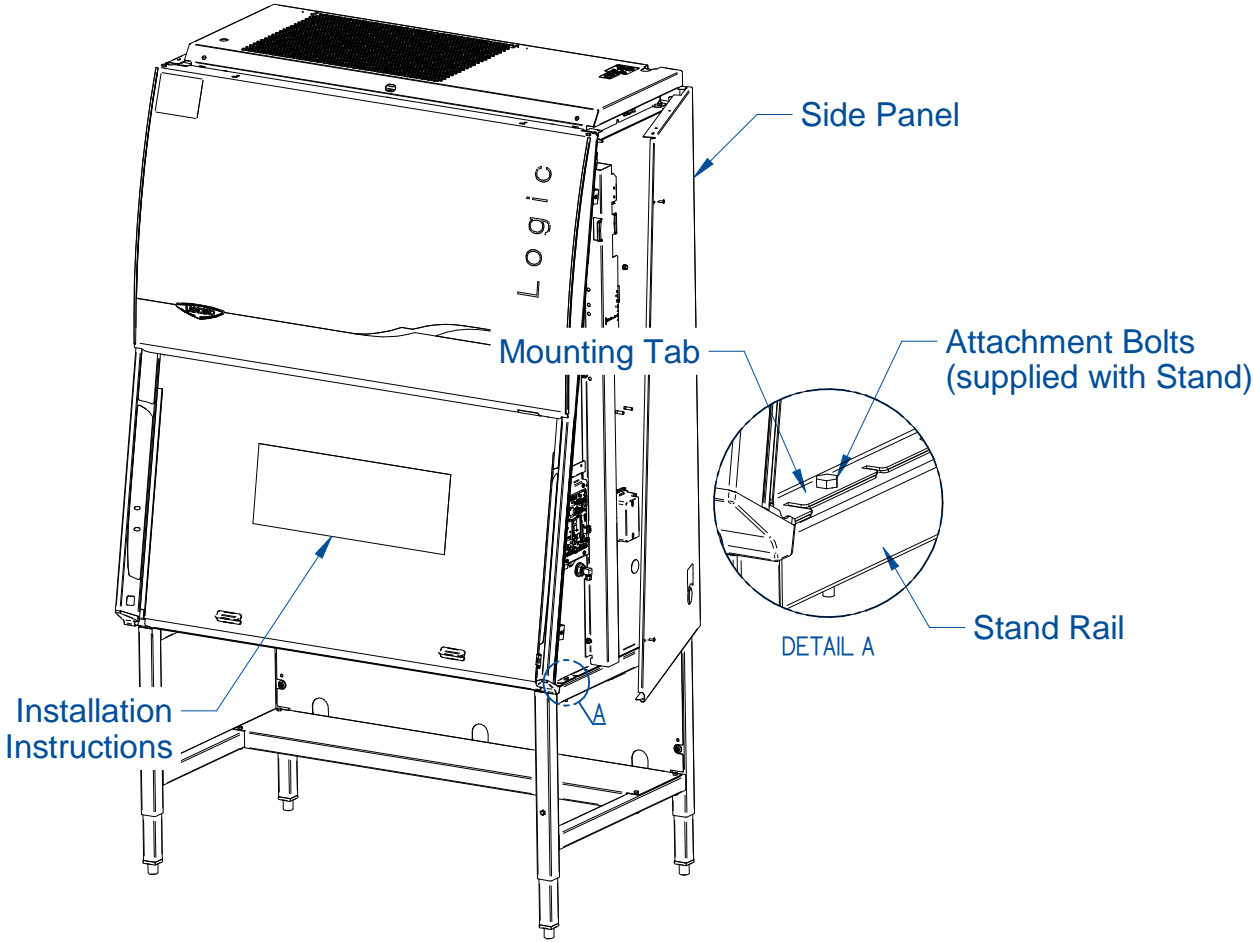

Step 3

The front sash will not slide open yet. The sash counterweights are pinned for shipment. The Side Panels must still be removed or hinged open for this step. Locate the Support Pin and Clevis Pin on each sash counterweight. See Figure 4-3. For convenience a yellow tag and string are provided. Locate each yellow tag on the front of the product, and follow the yellow string to each Clevis Pin. Remove the Clevis Pin (also referred to as a Cotter Pin), then pull the Support Pin toward the rear of the product until it is free. You will hear the counterweight drop a short distance when the Support Pin is removed. Discard the Tags, String, and Pins.

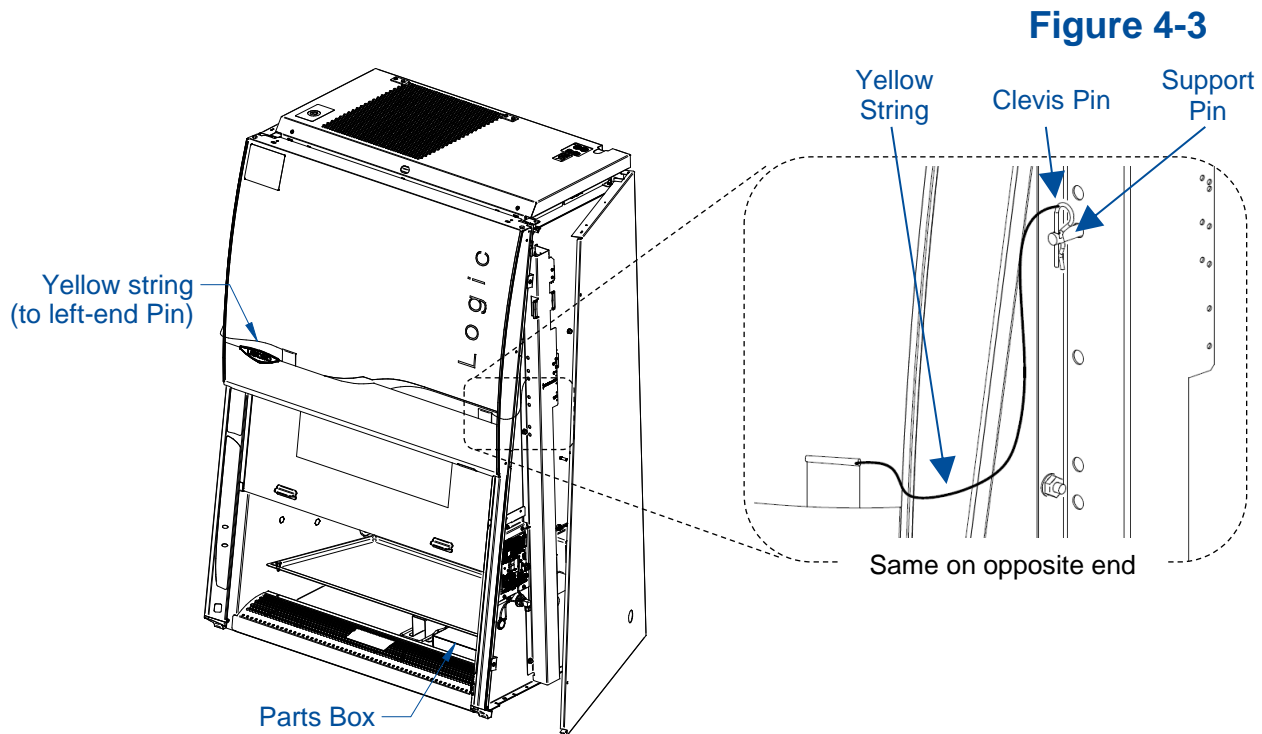

Replace or close each Side Panel and secure the panels with two screws per panel.

Raise the front sash. Lift the front edge of the stainless steel work surface, locate and retrieve the Parts Box. See Figure 4-3. The following items are located inside this box.

- User's manual thumb drive
- Drain valve assembly and fasteners
- Power cord
- Support Bolt with Locking Nut (see installation instructions for Stand if ordered).
- Punch Kit (for Scope-Ready™ Packages Only)
- Pure-Vu™ Seal & XL Pure-Vu™ Seal (for Scope-Ready Packages Only)

Electrical Connection

The product's power cord is located in the Parts Box removed in the final step of Unpacking (previous section). Connect the IEC end of the power cord to the IEC connector located on the rear side of the top electrical box. See Figure 4-4. Connect the plug end of the power cord into an appropriately rated outlet (see Electrical Requirements in [Section 2: Before You Install](#)).

Figure 4-4

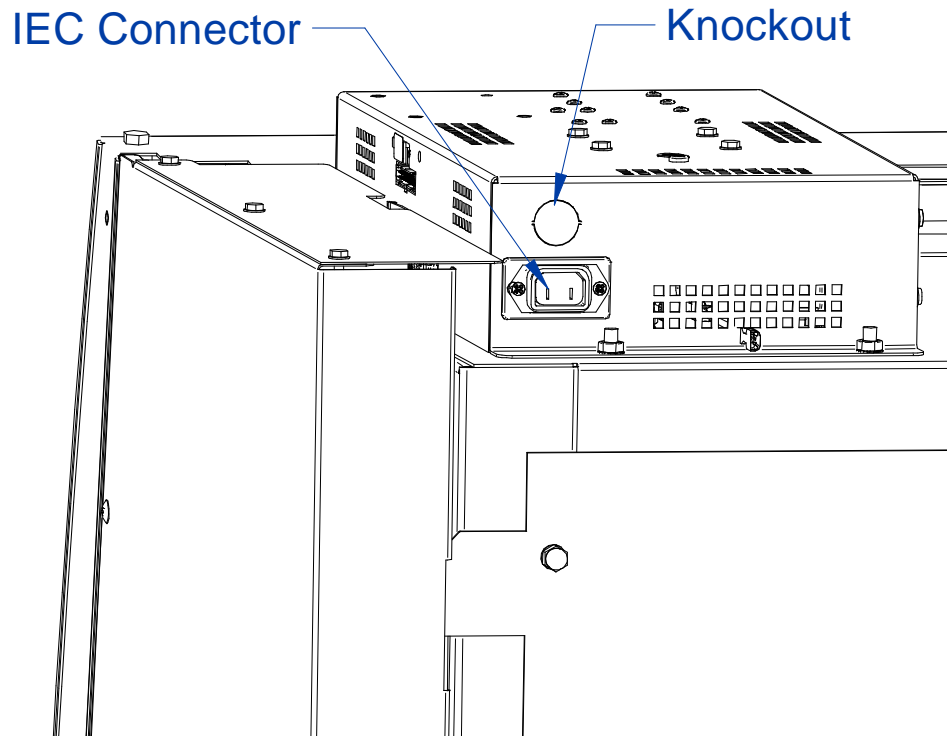

A knockout is also provided in the electrical box to allow for direct wiring of the product. Do NOT attempt to connect power via the knockout or otherwise directly wire the product without consulting your local codes and regulations, and it is highly recommended to utilize a licensed electrician to make this wiring connection. The wiring must meet the minimum gauge requirement for the current specified in [Section 2: Before You Install](#) listed under *Electrical Requirements*, and must be a dedicated wiring run to a circuit breaker appropriately rated for this product's electrical requirements.

Ethernet Connection

When an active ethernet connection is established, the cabinet is capable of the following:

- Automatically syncing the time and date
- Sending emails from the cabinet when Alerts occurs
- Receiving notifications when software upgrade is available.
- Upgrading the software via ethernet connection

To connect the building's ethernet to the biosafety cabinet, follow the steps below:

1. Locate the electrical control box on the top of the unit.
2. Locate the Ethernet Port on the side of the box, closest to the center of the cabinet (reference Figure 4-5).
3. Insert the Ethernet Cable into the Port.

Once connected to the ethernet port on the cabinet, see the [Utilizing Network Connection](#) sub-section of [Section 6](#).

Figure 4-5

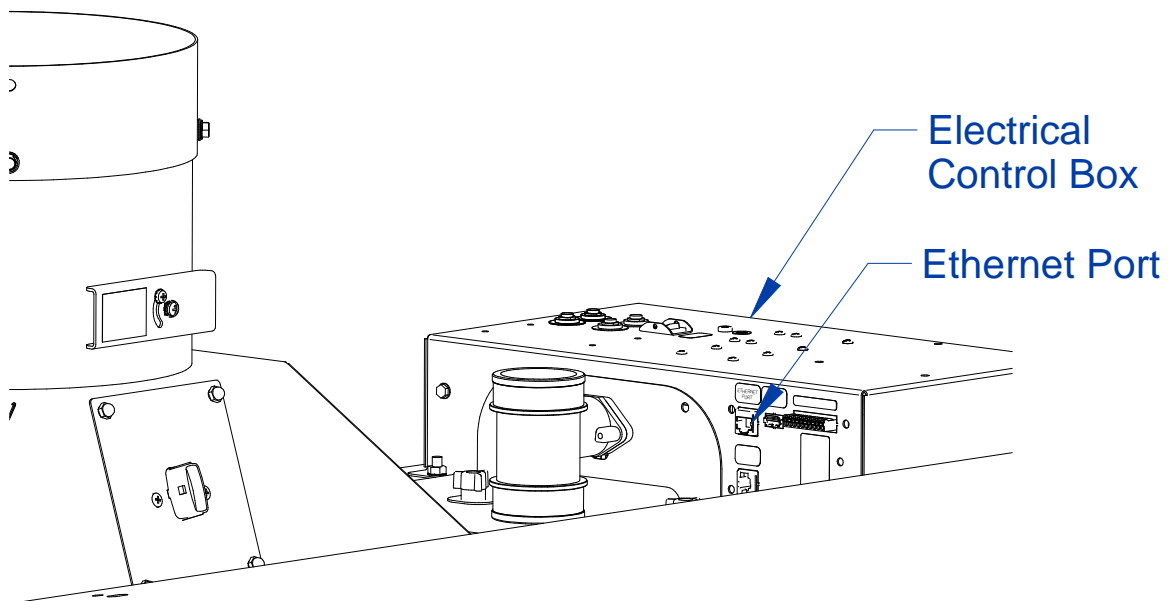

Service Line Connection

Service fixtures are not pre-installed on all models. If your model does not include a service fixture, this step may be skipped. A service fixture can be field installed at any time, the service fixture kit will contain instructions for installing the fixture. Follow the instructions below to make the plumbing connection to the service fixture.



Safe for use with vacuum, air, carbon dioxide, nitrogen, and argon. Not for use with water, steam or high purity gasses like oxygen and hydrogen. Contact Labconco for additional valve options.



Note: Some models have a solenoid valve connected to the service valve on the right side, rear position. The solenoid prevents gas from flowing to the service valve when the cabinet's blower is off, or there is a loss of electrical power. It is the only service valve position that can be fitted with a solenoid valve. Connect the gas service to the solenoid valve.

The incoming service line(s) should be connected to the tube compression fitting(s) on the outside of the liner wall as shown in Figure 4-6. Open the side panel, then:

1. Ensure that the tubing is $\frac{1}{4}$ inch O.D., soft metal, and that the end has been completely deburred.
2. Route the tubing from the rear of the cabinet, ensuring that it will line up with the slot in the back of the side panel. The slot is located from $8\frac{3}{4}$ to $11\frac{1}{4}$ inches (222 to 288 mm) from the bottom of the cabinet.



Note: Make sure that the tube routing will not contact any electrical wires. DO NOT loop service line tubing within the side panels of the cabinet.

3. Make sure that the nut on the 90 degree tube fitting is loose, but do not remove it. Make sure the tube ferrule is in the fitting.
4. Push the tube into the fitting until it is properly seated. The tube will go approximately $\frac{3}{4}$ inch (19 mm) into the fitting.
5. Tighten the tube fitting nut hand tight and then, using a $\frac{7}{16}$ -inch wrench, tighten it at least $\frac{3}{4}$ turn more.
6. Close the service valve in the cabinet and then slowly open the shutoff valve on the service valve. Test all fittings for leakage. Tighten the tube nut slightly if needed.

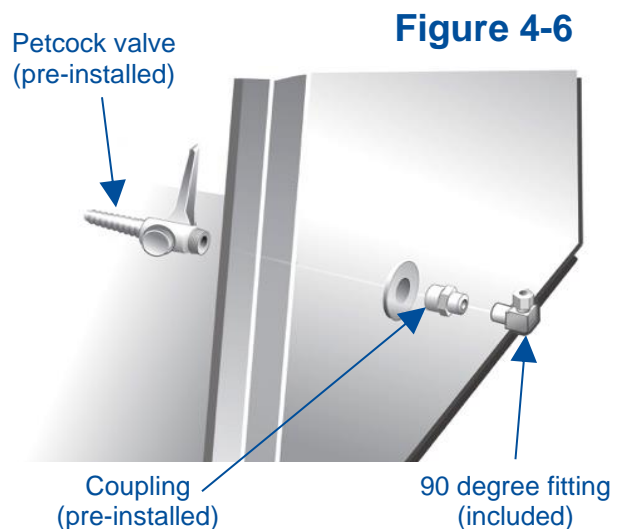

Drain Valve Installation (Optional)

A drain valve assembly is provided in the Parts Box. The drain allows for removal of large amounts of liquid trapped in the area underneath the work surface. The installation of the drain valve is not required. If not installing the drain valve, this section may be skipped.



Note: The work surface is heavy. Use caution when handling it.

1. Lift and remove the work surface by lifting on the knobs at the front of the work surface. Locate the cover sealed over the drain mounting holes.
2. Using a putty knife, remove and discard the stainless steel cover that is sealed over the drain mounting holes. Scrape out remaining sealant around the holes.

NOTE: The drain valve assembly attaches to the underside of the cabinet bottom.

3. Apply a light coating of silicone sealant (not provided) to the mounting surface of the drain flange. Attach the drain flange under the bottom of the cabinet as shown in Figure 4-7. Wipe off any excess sealant from the cabinet bottom. Ensure that the center drain hole is unobstructed.
4. Secure the drain assembly with the hardware provided. Tighten all hardware.
5. Make sure the drain valve is in the closed position.
6. Reinstall the work surface.
7. Allow the silicone sealant to cure for at least eight hours before exposing it to liquid.

Figure 4-7

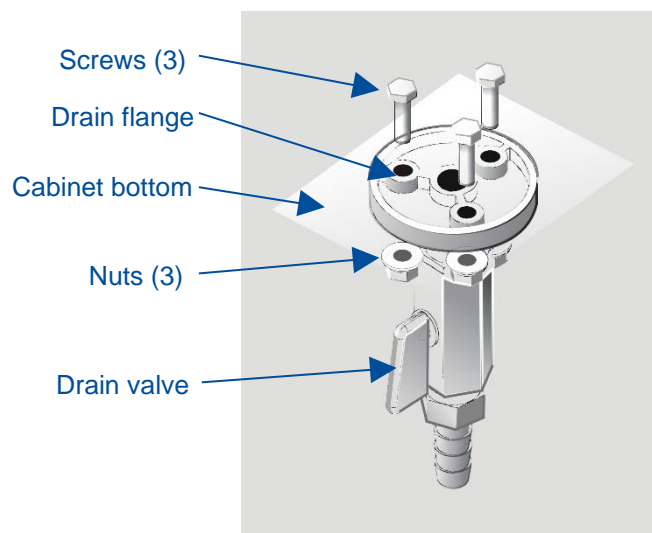

Exhaust Connection

The Cell Logic Type B2 biosafety cabinets are “total exhaust biosafety cabinets”, meaning all HEPA filtered exhaust air must be exhausted out of the laboratory.



WARNING: Type B2 Total Exhaust Biosafety Cabinets are designed to be connected to an appropriate exhaust system. Without verified inflow velocity, the cabinet may NOT contain hazardous particulate or gasses. Do not attempt to operate the biosafety cabinet when it is not connected to an appropriate exhaust system that has been inspected by a qualified certifier.



WARNING: Type B2 Biosafety Cabinets rely on external blowers (usually on the roof of a building) to exhaust 100% of the air entering the cabinet. If the building exhaust blower fails or is mistakenly turned OFF, the cabinet will become pressurized, resulting in airflow from the work area into the laboratory. It is imperative that the following be considered in a risk assessment:

- **Justify the type of work is appropriate for a Type B2 biosafety cabinet.**
- **Exhaust system must be reliable, maintained, frequently inspected and preferably redundant.**
- **Exhaust termination must be distant from other building air intake systems to prevent the re-entrainment of volatile chemicals into the facility.**



NOTE: The facility’s remote blower cannot run at its nominal flow rate with the sash completely closed. If the sash must be closed completely to utilize the internal UV Light (optional), then the facility’s remote blower must be shut off or its flow rate reduced by 90% or more for proper operation of the biosafety cabinet. The Cell Logic biosafety cabinet has a Remote Communications Board that contains dry relay contacts which can be configured to signal the facility’s remote blower to turn on and turn off (or reduce speed) as the biosafety cabinet’s operational needs require. For further information, contact Labconco’s Product Service Department or refer to the Logic Technical Manual. A remote electrical switch to control the facility’s remote blower can also be installed near the biosafety cabinet for manual control of the remote blower.



WARNING: THE EXHAUST CONNECTION IS A SEALED EXHAUST SYSTEM FROM THE TOP OF THE CABINET TO THE REMOTE BLOWER. THE EXHAUST SYSTEM CONTROL SHOULD BE DEDICATED TO A SINGLE BIOSAFETY CABINET. THE CABINET IS EQUIPPED WITH AN EXHAUST AIRFLOW ALARM, SUCH THAT AN ALARM SOUNDS, AND THE CABINET BLOWER SHUTS OFF IN THE EVENT OF INSUFFICIENT EXHAUST AIRFLOW.



If your research involves the use of toxic compounds or volatile materials, contact your facility’s safety officer or Labconco to ensure that your Cell Logic and its exhaust system are compatible with the materials you will be working with.

Microscope Installation (optional)

In order to successfully install a user-supplied microscope in a Cell Logic biosafety cabinet with Scope-Ready package, please follow the steps below and refer to Figure 4-9 as well as [Appendix E](#).



Note: The work surface is heavy. Use caution when handling it.

1. Before installing a microscope, locate the Stand-Still™ Isolation Platform that is packaged in a separate carton underneath the work surface. **Note:** Stereoscopes will typically require the Stand-Still XL Isolation Platform; more information can be found at labconco.com.
2. Install the Stand Still Isolation Platform so that the leading edge is in line with the work surface leading edge. See [Appendix E](#) for typical pictures of proper set-up of the Stand-Still Isolation Platform.
3. With the sash in the up position, place a user-supplied microscope inside and on top of the Stand-Still Isolation Platform. Remove the microscope eyepieces.
4. The Cell Logic biosafety cabinet with Scope-Ready Package includes one Pure-Vu Seal that requires 0.5" (12.7 mm) diameter holes spaced approximately 2.75" (69.9 mm) apart and located from the base of the microscope to the centerline of the eyepiece. The eyepiece holes can be cut with the 0.5" (12.7 mm) diameter hole Punch Kit (Catalog Number 4027801) supplied with your cabinet.



For your convenience, pre-cut accessory Pure-Vu Seals can be found at labconco.com, and may be an easier installation.

5. If punching the 0.5" (12.7 mm) diameter holes, with the microscope eyepieces removed line up the centerline of the eyepiece base with the seal. Then mark the centerline of each eyepiece hole spaced at approximately 2.75" (69.9 mm).
6. Remove the 14 screws (#6-32 x 0.25") that retain the Pure-Vu Seal.
7. Either reinstall one of the pre-cut accessory Pure-Vu Seals from Section 9 or punch the holes in the blank seal supplied and then re-install the seal. For your convenience, see [Appendix E](#) for installation of pleated Pure-Vu XL Seals used with stereoscopes requiring frequent eyepiece height adjustment of +/- 2.0" (51 mm).
8. After the seal is re-installed, then move the microscope forward to carefully stretch the Pure-Vu Seal over both of the microscope eyepiece bases.
9. Finally, re-install the microscope eyepieces.

10. The Pure-Vu Seal should now provide an optimum seal for safe airflow and ergonomic visibility.

Figure 4-9

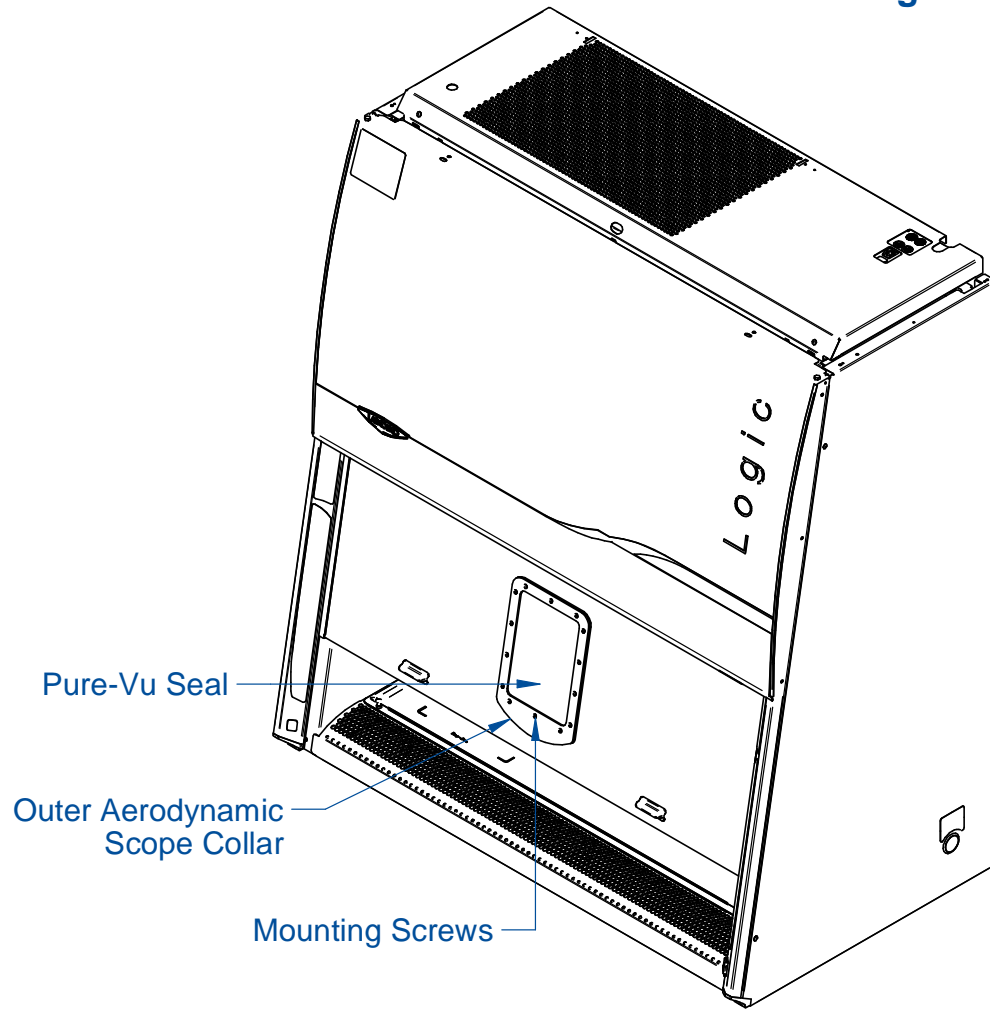

Circulator Installation (optional)

In order to successfully install a user-supplied circulator on a Cell Logic Biosafety Cabinet with Temp-Zone™ package please follow the steps below and refer to Figure 4-10:



Note: The work surface is heavy and two Easy-Clean™ Prop Rods are provided to pivot and support the Temp-Zone work area and the work surface.

1. The Temp-Zone work area has supply and return lines for the user-supplied circulator. Refer to Figure 4-10 and locate the two quick connect elbows on the left side of the cabinet behind the left side panel.
2. Find a suitable place next to the cabinet or underneath the cabinet to place the circulator. Accessory shelves for small circulators are available from labconco.com. Larger circulators should be placed on the floor.
3. Pivot the work surface up and use the Easy-Clean Prop Rods to support the work surface. Then locate the tubing, insulation, and quick connect fittings shipped with your Cell Logic. The tubing is 3/8" OD (9.5 mm) and tube inserts must be placed inside the tubing to properly support the tubing inside the quick connect fitting. 20 feet (6.1 meters) of tubing length is provided for your convenience.



Note: The tube inserts prevent the tubing from collapsing at connection points and must be used.

4. Plan, route and cut the tubing from the two elbows on the left side of the cabinet to the circulator.
5. Locate the quick connect fittings (3/8" tube x 1/8 NPT, 3/8" tube x 1/4 NPT, and 3/8" tube x 3/8 NPT) and install the appropriate fittings to the user-supplied circulator with appropriate pipe sealant or PTFE tape.
6. Place tube inserts in all ends of the cut-to-size tubing.
7. Cut and install the insulation around the cut tubing lengths.
8. Insert cut tubing lengths into the elbows on the cabinet and then install both tubing lengths into the circulator to complete the water circulator loop.
9. Read and follow the circulator instructions before operating. The circulator should have a minimum flow rate of 0.5 GPM (1.9 LPM). In all cases, the temperature of the circulator will not equal the temperature of samples on the Temp-Zone. Factors such as the sample vessels, sample sizes, aluminum tube racks, and length of tubing connecting the circulator to the Temp-Zone can influence the sample temperature. Circulator settings to hold heated incubator sample temperatures may require 0.3-2.0°C higher temperatures than the desired

sample temperature. Furthermore, circulator settings to maintain chilled refrigerated samples may require 0.3-3.0°C colder temperatures than the desired sample temperature. Experimentation is necessary to achieve proper sample temperatures.

10. For chilled applications, the Temp-Zone work area comes with a drain line installed that can be routed to the cabinet's drain valve, if desired. This Temp-Zone drain line installation is optional for chilled applications should excessive condensation occur under the work surface. Simply snap in the supplied press-fit elbow to the drain valve shown in Figure 4-10. Follow the diagram to finish the installation.

Figure 4-10

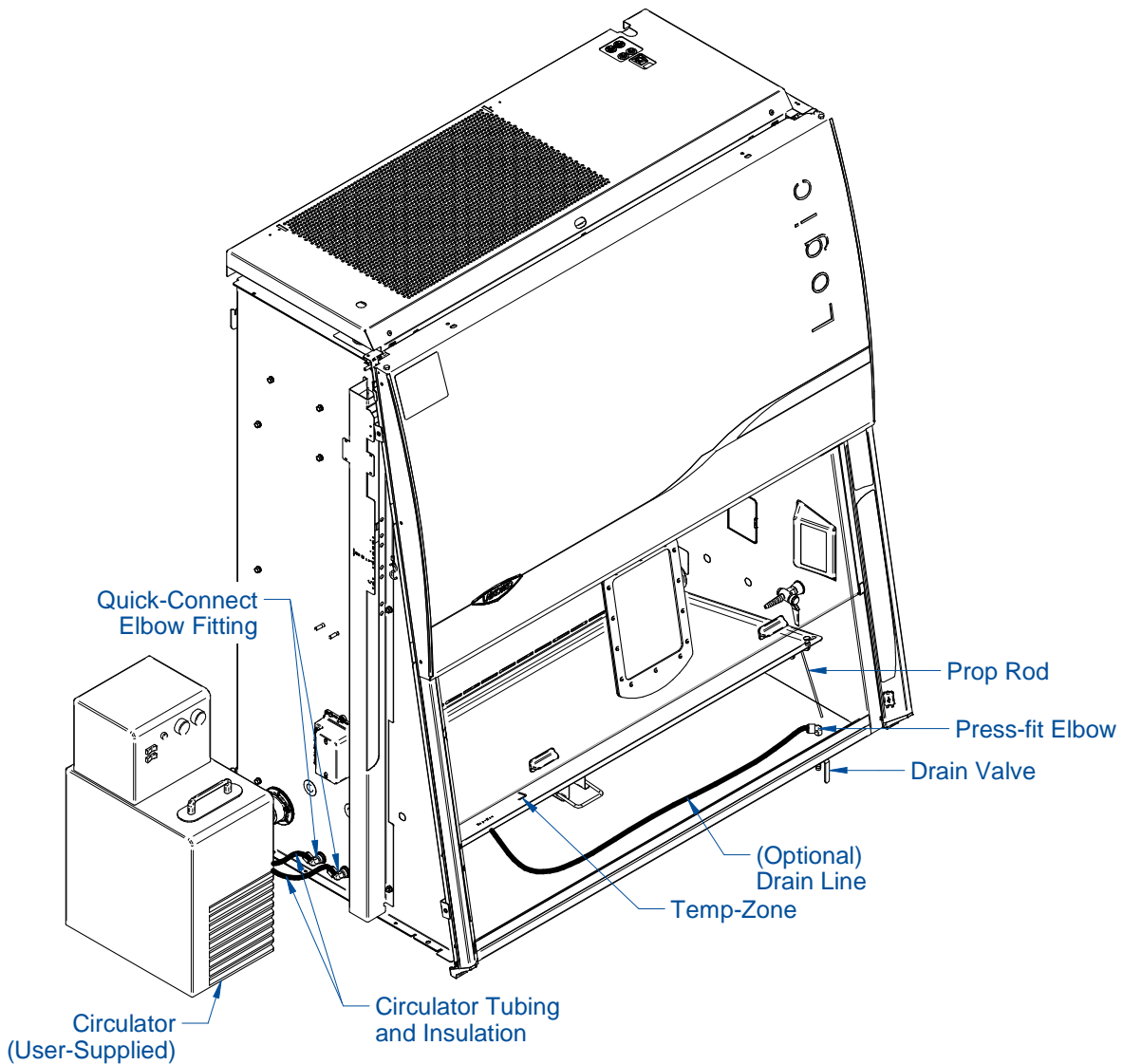

Certification

Prior to use, a qualified certifier should certify a biosafety cabinet. Under normal operating conditions, the cabinet should be recertified at least annually and when relocated or serviced. The certifier should perform the following tests, as recommended in NSF/ANSI Standard Number 49 in effect when the cabinet was manufactured:

- Downflow Velocity Profile Test
- Inflow Velocity Test
- Airflow Smoke Patterns
- HEPA Filter Leak Test
- Optional Exhaust Alarm Test and Operation
- Vibration Test *
- Noise Level Test *
- Lighting Intensity Test *

*These tests are user comfort related tests and may be omitted at the user's or certifier's discretion.

If you have any questions regarding certification agencies or help locating one, contact Labconco's Product Service Department at (800) 821-5525 or +1 816-333-8811.

Detailed information for product certification is located in the Logic Technical Manual.

5: Performance Features

The Cell Logic Type B2 biosafety cabinet protects items placed on the work surface, the personnel working with material inside the cabinet, and the lab environment, when operated to manufacturer's specifications and proper aseptic techniques are employed.

This protection is provided through the use of laminar airflow, HEPA filtration, careful cabinet construction, and Constant Airflow Profile™ (CAP) ECM motors. Each of the key performance features are detailed in this section.

Laminar Airflow

Laminar airflow is defined as the movement of a body of air in a single direction, with a uniform velocity. In practice, the laminar downflow of air in the cabinet captures any aerosol generated in the work area of the cabinet, and directs it to the HEPA filters. In order to be true laminar downflow, a number of individual downflow velocity test points, commonly referred to as the Downflow Velocity Profile, must be +/- 16 feet per minute (0.08 m/s) of the average of all the test points.

Figure 5-1

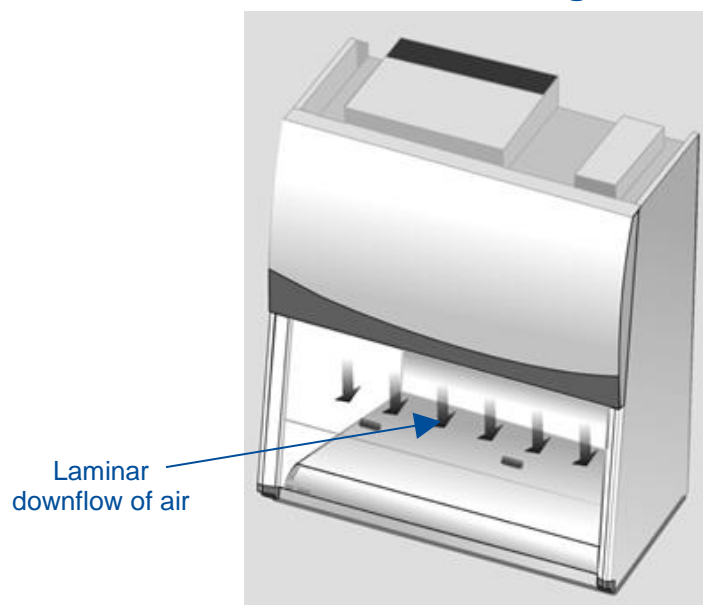

Directional Airflow

Directional airflow also plays a key role in cabinet performance. Air is drawn into the front of the cabinet at the front grille. This “curtain” of air makes it more difficult for aerosols to escape out of the work area of the cabinet and into the outside environment. This airflow is often calculated and referred to as the **Inflow Volume** or **Average Inflow Velocity**. This is illustrated in Figure 5-2.

Figure 5-2

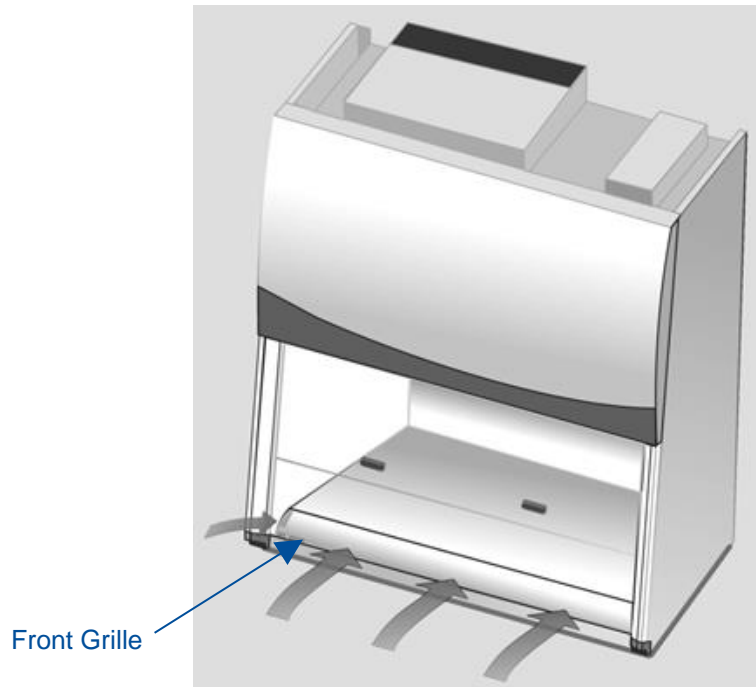

Cabinet Air Intake (Front Grille)

The location, size, and pattern of the grille openings in the work area affect cabinet containment and performance. The front grille’s airfoil profile, and air intake openings play an important role in establishing Directional Airflow, as described previously. See Figure 5-2.



Note: Do not block or obstruct the grille openings of the biosafety cabinet.

HEPA Filters

HEPA filters are disposable, dry-type particulate filters. The filter material or media is typically made of borosilicate microfibers formed into a thin sheet, in a process similar to the production of paper. This sheet is folded, or pleated to increase its surface area. The pleats are typically held in place by beads of glue that add rigidity to the media pack. The pack is then set into a frame, and sealed as shown in Figure 5-3.

The HEPA filter manufacturer establishes the efficiency of the filter by challenging it with an aerosol of known particle size. The number of particles that penetrate the filter are quantified, and this establishes the efficiency of the filter. The HEPA filters used in the biosafety cabinet are at least 99.99% efficient in removing particles 0.3 micron.

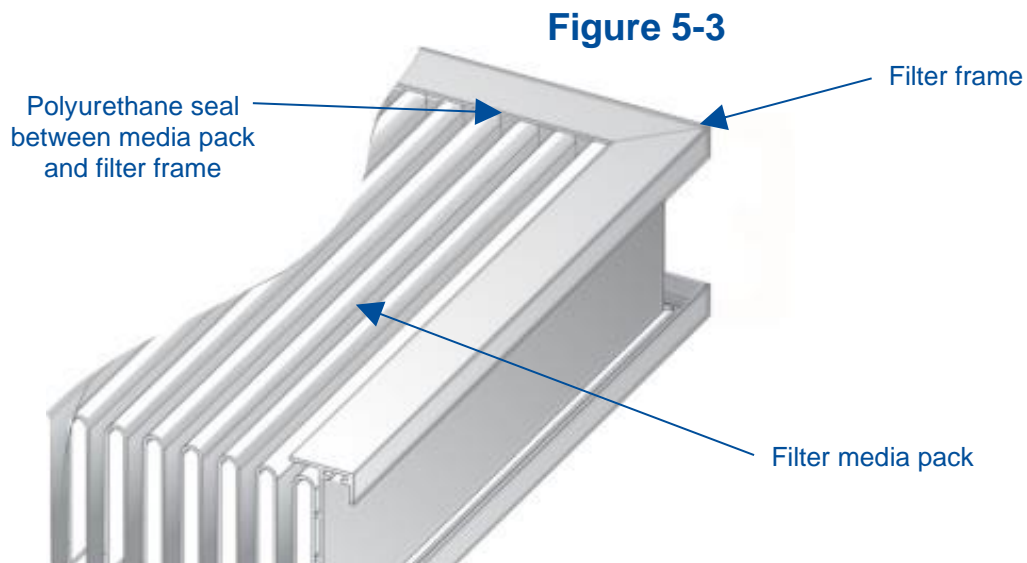

Note: The HEPA filter media is very fragile. DO NOT touch the media. If you think the media of a HEPA filter is damaged, DO NOT USE THE CABINET. Have the HEPA filter integrity tested by a certifier before using the cabinet.



Note: HEPA Filters are only effective against particulate material. Gases and vapors will pass through the filter.

ULPA Filters

Optional ULPA filters may be used to replace the standard HEPA filters in this product. ULPA filters have the same properties as described above except they are rated at least 99.999% efficient in removing particles 0.1-0.2 or 0.2-0.3 micron in size.

Motor/Blower

The motor/blower assembly pulls room air into the front of the cabinet, and re-circulates it internally. During its recirculation, the air is split into two separate streams. One path leads through the exhaust HEPA filter and out of the unit. The second path flows through the supply HEPA filter, which then flows down through the work area, as shown in Figure 5-4. The motor in the cabinet is an electronically commutated motor (ECM). The ECM is a brushless DC motor that includes its own power supply to convert the incoming alternating current to direct current, as well as its own microprocessor to control and measure the motor's operation. The motor utilizes Labconco's exclusive Constant Airflow Profile™ (CAP) program to deliver a consistent volume of air, throughout the life of the cabinet.

Figure 5-4

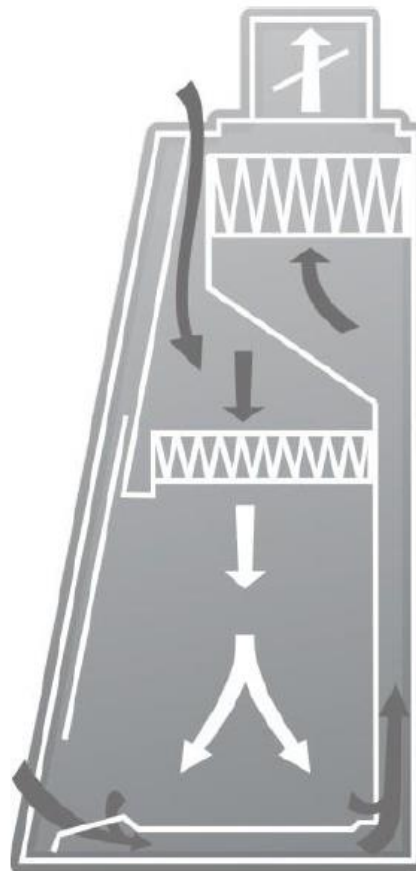

Airflow Sensor

The airflow sensors, located above the Exhaust HEPA filter and on the top surface of the cabinet near the Electrical Control Box, constantly monitor the flow of exhaust and intake cabinet air. If the exhaust falls below a safe level, the control board turns off the

cabinet blower, and sounds an audible and visual alarm. This prevents the escape of hazardous material from the front of the cabinet, in the event of an exhaust system failure. The airflow sensor reading is shown on the display as Inflow in feet per minute (FPM) or meters per second (M/S).

UV Lamp (optional)

The optional UV lamp generates a primary wavelength of light of 254nm. A secondary emission is in the visible (blue) wavelength, resulting in the characteristic blue color while operating. UV light at this wavelength is biocidal, primarily by creating thymine dimers in DNA. These dimers prevent the correct transcription of the DNA into RNA, resulting in cellular death or viral inactivation. In order to be effective, the UV light must directly strike the nucleic acid, and its effectiveness can be diminished or negated by dissolved proteins or metals, or by other UV-opaque substances protecting the target nucleic acid.

Because of its limitations, UV light should be used as an adjunct to good surface disinfection practices. In order to achieve optimum performance from the UV lamp, it should be replaced after 6,000 hours of operation or less, and the exterior surface of the lamp should be kept clean and free of dust.



Note: The product records the number of hours of operation of the UV light. You can program in the number of hours it will operate before a replacement message is displayed.



Note: UV irradiation is absorbed by the tempered safety glass of the sash. Independent research has shown that the level of UV irradiation on the outside of the cabinet's sash is equal to background radiation levels.



Note: The UV sensitivity of a target organism varies, depending on the UV output of the lamp, the genus and species of the organism, the medium the agent is suspended in, etc. Contact the Health and Safety Officer at your facility for UV light use and recommendations.

Scope-Ready™ Package (optional)

Models with the Scope-Ready package option allow a user-supplied microscope to be integrated into the safety cabinet. On these models, two features work together to assure containment and reduced vibration:

Pure-Vu™ Seal

The Pure-Vu Seal includes a 7 inch (178 mm) wide x 10 inch (254 mm) high sash cutout that accommodates most microscopes' eyepieces. The clear, disposable eyepiece seal prevents contaminants from escaping while providing ergonomic visibility into the cabinet. The removable seal attaches tightly to an aerodynamic, epoxy-coated steel collar. The unique teardrop shape of the aerodynamic collar design keeps contaminants

contained with the microscope in place. The Pure-Vu Seal conforms to both ASHRAE 110 and NSF 49 testing criteria.

Stand-Still™ Isolation Platform

The Stand-Still Isolation Platform supports the microscope on the cabinet's work surface and removes up to 94% of vertical and horizontal vibrations. ASHRAE 110 and NSF 49 testing confirms this unique elevated, aerodynamic base ensures safe airflow.

Constructed of seamless Type 304 stainless steel, the isolation platform is non-porous, easy to clean, and autoclavable.



Note: Always remove the rubber isolation feet prior to autoclaving. The 12 inch (305 mm) wide x 18.75 inch (476 mm) deep platform accommodates most microscopes. See [Section 9: Accessories](#) for ordering an extended Stand-Still XL Isolation Platform for use with microscope bases that extend over the front of the lower work surface.

Temp-Zone™ Package (optional)

Models with the Temp-Zone package option include a temperature-controlled area 10.5 inch (267 mm) wide x 12 inch (305 mm) deep. Note: the temperature-controlled area is 7 inch (178 mm) wide x 12 inch (305 mm) deep on 3 foot models. Samples heated in an incubator or chilled in a refrigerator may be transferred to the Temp-Zone and kept at optimum temperature. Quick connection fittings on the left side of the cabinet attach to a user-supplied circulator that continually delivers heated or chilled water through channels located underneath the Temp-Zone area of the work surface. Uniform temperature distribution is maintained on the Temp-Zone area of the work surface.

6: Cell Logic Type B2 Operating System

The Cell Logic Type B2 biosafety cabinet provides clear status information on the touch-screen display and user control with the keypad (Figures 6-1 & 6-2). Read this section along with [Section 7: Using Your Cell Logic Type B2](#) to fully understand the features and controls of this product.

Home Screen

The *Home Screen* will display the following information (Figure 6-1).

Figure 6-1

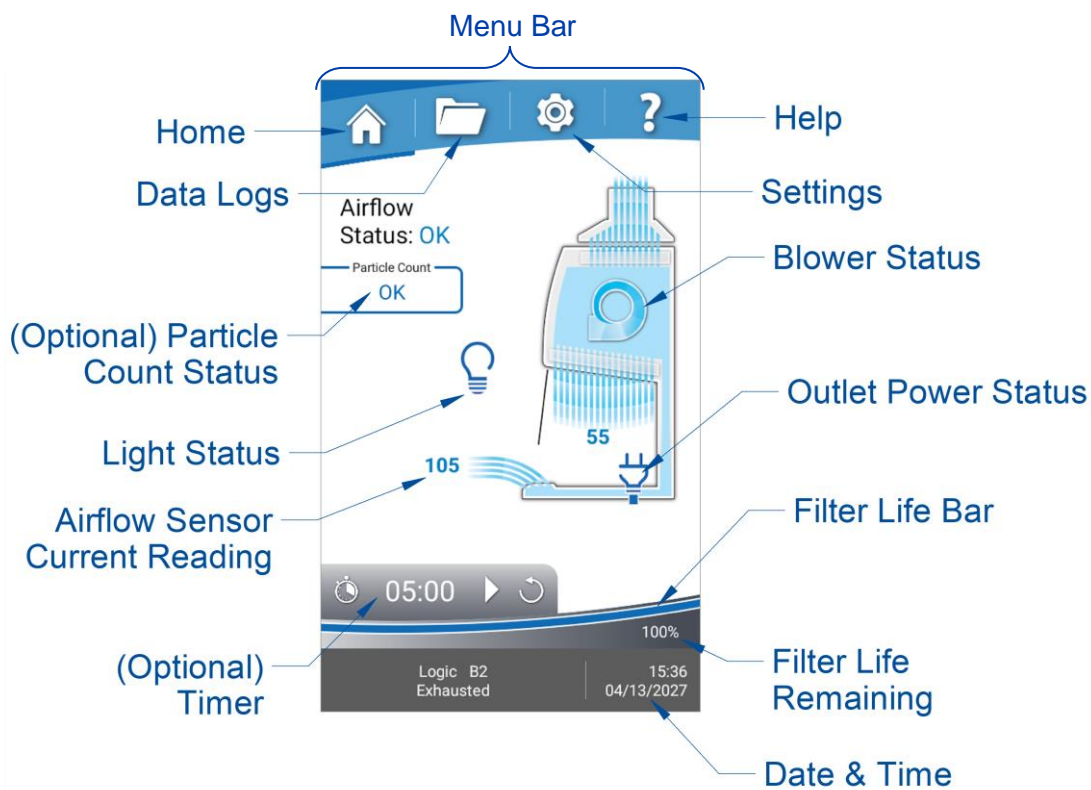

When the glass sash is closed, the blower and light icons may change as follows:



Display Sleep Mode

The LCD display will enter a relaxed mode (screen appears black) when the blower is off. If the blower is off, and no keys are pressed on the keypad, after the Screen Timeout Time (adjustable in *Settings>Display*) the screen will automatically turn off to relax the LCD display, which extends its life. If the blower is on, and no keys are pressed on the keypad, the screen will automatically dim after the set timeout time has elapsed. Any key press, screen touch, alarm or alert will wake the screen.

Keypad

The keypad button functions are explained in detail in [Section 7: Using Your Cell Logic Type B2](#), under the subsection *Keypad*. A summary description is provided here with Figure 6-2.

Figure 6-2

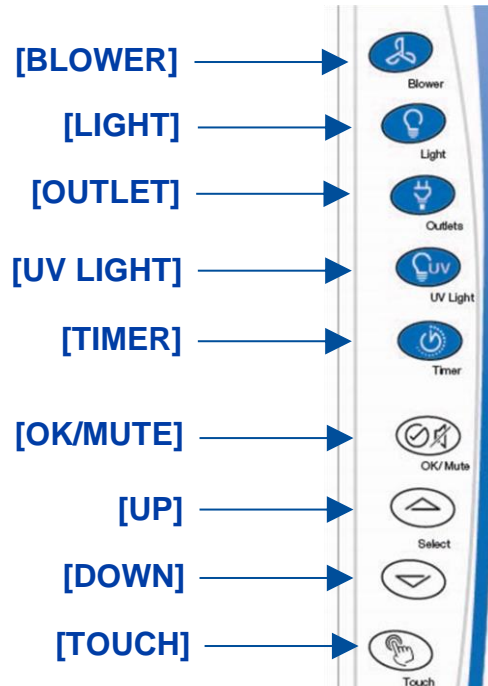

Navigating the Data Logs Menu



Keypad button presses and screen touches are shown as **[BLUE WITH BRACKETS]**. Menu screen selections are shown as *green italics*.

This section will cover in detail the different options available in the *Data Log Screen*. To access the *Data Log Screen* from the *Home Screen*, press **[Data Logs]** (represented by the folder-icon) on the Menu Bar of the display. The display will change to the *Data Log Screen* (see Figure 6-3). To return to the *Home Screen*, press **[Home]** along the same Menu Bar.

Each file will be named as follows “Log_YYYY-MM-DD_XX”, where YYYY = Year, MM = Month, DD = Day, and XX = 01 to 99 for the first through 99th log of that specific day as shown in Figure 6-3. The data log default rate is 10 seconds. The default data rate can be adjusted in the *Settings Screen* (instructions detailed later in section). The data logs are automatically deleted at a default rate of 1 year. The default deletion rate can be adjusted in the *Settings Screen* by following the instructions later in this section.

A data log can be selected from the list by touching the data log file name. When a data log has been selected, the row will be highlighted as shown in Figure 6-3. To select multiple log files, hold down a single log until the multiple select checkboxes are visible and select all the log files desired. When selected, the buttons along the bottom of the screen will activate (**[VIEW]**, **[EXPORT]**, **[DELETE]**). Only one log file can be viewed at a time, but multiple log files can be exported or deleted. Log files can be exported to a flash drive in two different file types: CSV and PDF. If a data log is currently running (collecting data), the *Running Man* icon will appear to the left of the data log file name.

Depending on the model, the data log will collect several parameters for each program at a user-selected data rate. Although the log file only allows viewing of up to 5 parameters on the display (as shown in Figure 6-3), all parameters are stored with the data log, and will be viewable when the log file is downloaded and viewed on a computer. The parameters are as follows:

- Date (Default)
- Time (Default)
- Blower (Default)
- Airflow Status (Default)
- Alert (Default)
- Light
- UV Light (Optional)
- Outlet
- Blower RPM
- Blower PWM
- AFS Inflow
- AFS Downflow
- Particle Count Status (Optional)

To change what parameters are visible on the display screen, select the **[Gears]** (shown in the top left-hand corner of Figure 6-3).

To search through individual logs by a phrase or numerical value, use the *Search Function* by touching **[Search]** (represented by the magnifying glass icon) shown in Figure 6-3. Type the desired search phrase into the bar. To move through the found matches of the search phrase, touch the **[Forward]** and **[Backward]** magnifying glass icons. Touch the **[X]** (reference Figure 6-3) to exit the *Search Function*.

Figure 6-3

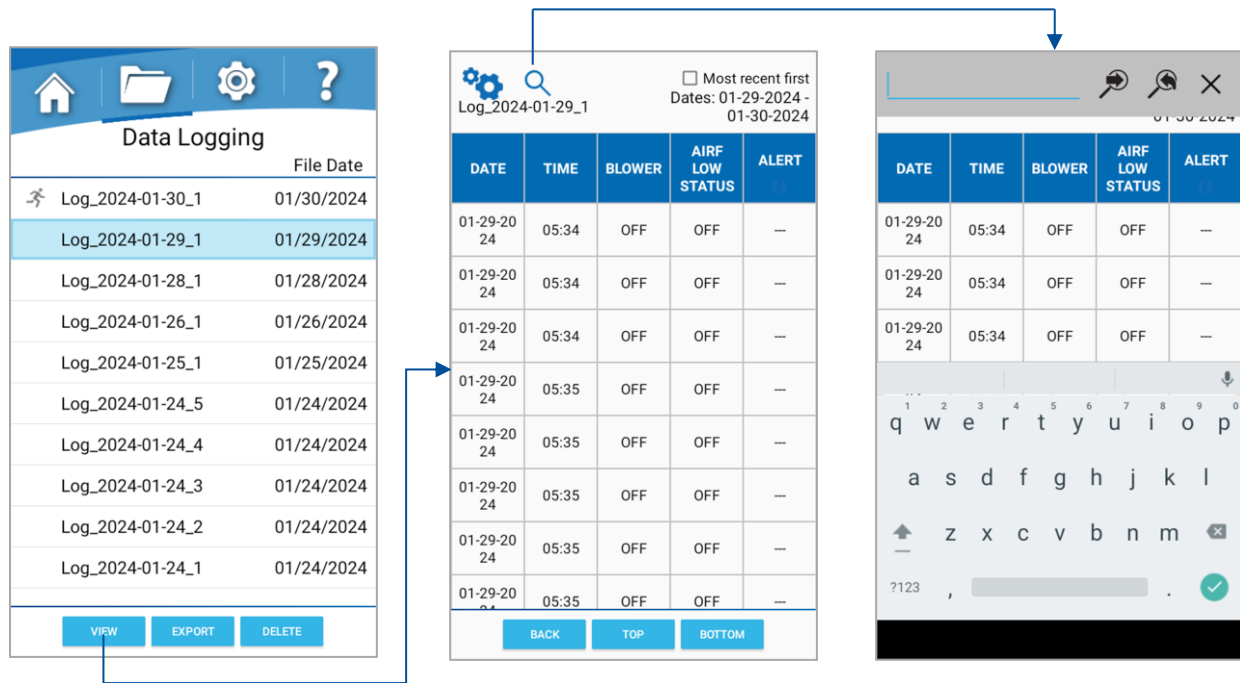

All alerts/alarms will be recorded and represented with a code. The alert code descriptions can be seen by touching the **ALERT** column heading (as shown in Figure 6-3) and are as follows:

Table 6-1

Alert Codes	Descriptions
AD	Check for Airflow Blockage
BF	Blower Failure
EA	Exhaust Airflow Check
EX	Exhaust Failure
FL	Filter Life at 0%
HE	Building Exhaust Too High
PL	Power Loss
SA	Sash Out of Position

Navigating the Settings Menu



Keypad button presses and screen touches are shown as **[BLUE WITH BRACKETS]**. Menu screen selections are shown as *green italics*.

To access the *Settings Screen* from the *Home Screen*, press **[Settings]** (represented by the gear-icon) on the Menu Bar of the display. The display will change to the *Settings Screen* (see Figure 6-4). To return to the *Home Screen*, press **[Home]** along the same Menu Bar.

Figure 6-4

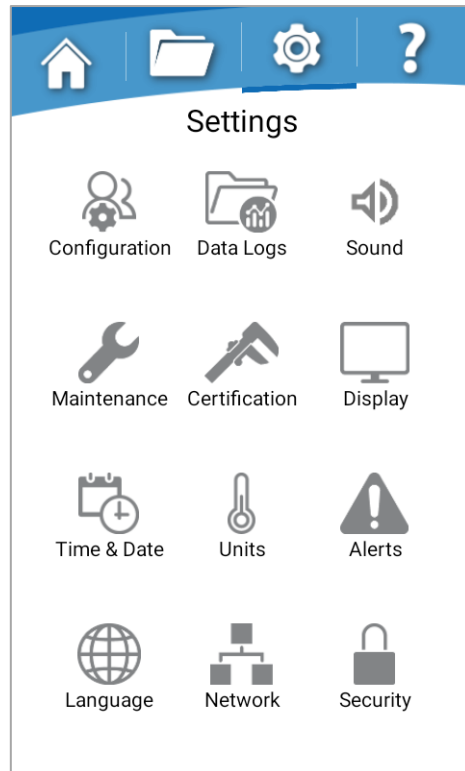

Configuration Submenu

Touch **[Configuration]**. This screen configures optional features. Reference Figure 6-5. A security code is required for this screen. When prompted, enter **[1] [9] [2] [5]** or the user/admin PIN chosen for the device.

- *UV Light* – Touching the toggle between ON & OFF will enable or disable the UV Light features. If the UV package is factory installed, this toggle will be enabled. If removed or field installed, adjust the toggle accordingly.
- *UV Light On Time* – The time that the UV light remains on before auto shutting off can be set using the scroll down menu. The options are 10 minutes through 120 minutes in increments of 10 minutes with an option for infinity. The default for the UV Light On Time is 30 minutes.

- **Downflow Sensor (AFS)** – Touching the toggle between ON & OFF will enable or disable the downflow AFS features.
- **Spectrum Connection** – Touching the toggle between ON & OFF will enable or disable the Spectrum Blower Connection features. The Spectrum connection will be visible in **Certification>Certify**.
- **Particle Counter** – Touching the scroll down menu to change from disable to a 4-20mA output signal will enable the particle counter features.
- **Show Timer on Home Screen** – Touching the toggle between ON & OFF will enable or disable the timer on the **Home Screen** (shown in Figure 6-1 of this section).
- **Gas Valve** – Touching the toggle between ON & OFF will enable or disable the Gas Valve features. If the Gas Valve is factory installed, this toggle will be enabled.
- **Device Name** – The default cabinet name is ‘Labconco Biosafety Cabinet’. To alter this name, touch the current device name and use the keyboard to enter a new name. When finished, touch the **[Green Checkmark]**.

To save any changes, touch **[Save]**.

Figure 6-5

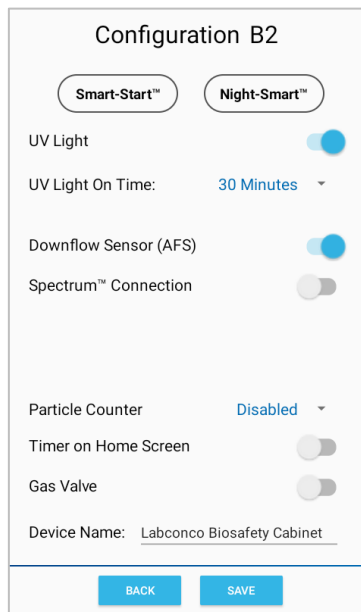

Setting Automatic Operation Options (Night-Smart™ / Smart-Start™)

The cabinet allows configuration to activate functions automatically when the sash is opened or closed. The optional automation would control the blower and lights of the BSC.

To automate the BSC’s Blower or Lights when the sash is raised, touch **[Smart-Start]** in the **Configuration Screen** (reference Figure 6-5). The **Smart-Start Screen** shows the currently selected option at the top of the screen. Reference Figure 6-6. If you want the

cabinet Blower to start every time the sash is opened from the closed position, touch the **[Blower On]** icon to activate. The description under *Open Sash* should read 'Start Blower'. If **[Blower Off]** is selected, the blower must be manually started from the keypad. If you want the cabinet Lights to illuminate every time the sash is opened from the closed position, touch the **[Light On]** icon to activate. The description under *Open Sash* should read 'Light On'. If **[Light Off]** is selected, the lights must be manually illuminated from the keypad.

To save any changes, touch **[Save]**.

To automate the BSC's UV Light when the sash is closed, touch **[Night-Smart]** in the *Configuration Screen* (reference Figure 6-5). The *Night-Smart Screen* shows the currently selected option at the top of the screen. Reference Figure 6-6. If you want the UV Light to illuminate every time the sash is closed, touch the **[UV Light On]** icon to activate. The description under *Close Sash* should read 'UV Light On'. If **[UV Light Off]** is selected, the lights must be manually illuminated from the keypad.

To save any changes made, touch **[Save]**.

Figure 6-6

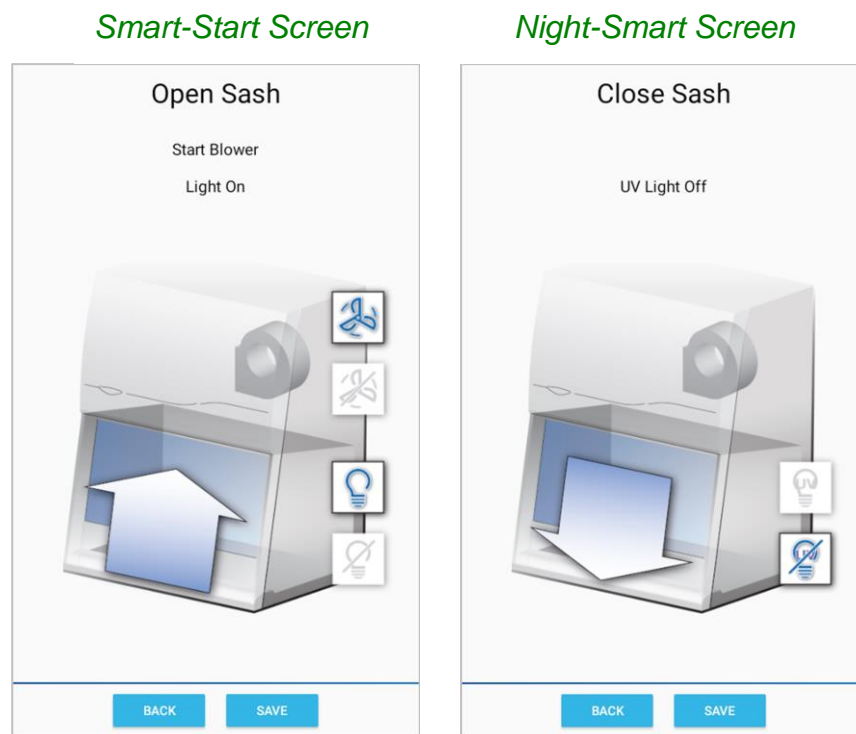

Adjusting Sound

Touch **[Sound]**. The audible tones for various conditions or actions can be modified and/or silenced in the sounds sub-menu as listed below. To save any changes, touch **[Save]**. To exit without changes, touch **[Back]**.

- *Touch Sounds* – The ON/OFF toggle enables or disables audible touch of the screen.
- *Alarm Sounds* – Audio tones can be chosen from the drop-down menu.
- *Alert Sounds* – The ON/OFF toggle enables or disables audible alert. Audio options can be chosen from the drop-down menu.
- *Timer Sounds* – The ON/OFF toggle enables or disables audible timer. Audio options can be chosen from the drop-down menu.
- *Sash Sounds* – The ON/OFF toggle enables or disables sash movement notification tune. Audio options can be chosen from the drop-down menu.



Audible tones associated with alarms cannot be muted.

Selecting a Language

Touch **[Language]**. The current language will be displayed along the top of the Language Selection Pop-up. Choose from the available languages:

- English
- Spanish
- French
- German
- Italian
- Chinese
- Japanese
- Portuguese

Setting the Clock

Touch **[Time & Date]**. Use the *Time and Date* pop-up to choose Clock Format (12 or 24 hour), and then either manually set the Time and Date, or enable Auto Update, which (if the cabinet is connected to a valid Ethernet port) will auto update the time and date. With Auto Update the following settings need to be entered:

- *Time Zone* – Enter the Greenwich Mean Time (GMT) offset value for your location (integer value between -12 & +12).
- *NTP server* – Enter the “web address” (URL) of the NTP server (of your choice) that will provide clock synchronization data to the cabinet via the Ethernet connection. A common site is: time.nist.gov
- *Daylight Savings (ON/OFF)* – Enabled/disabled for areas observing Daylight Savings Time (DST).

Selecting the Units of Measure

Touch **[Units]**. This screen allows the user to change the units of measure for various sensors. Touch the desired drop-down field, and make selection:

- *Length* – Select the desired units of measure: inches or centimeters
- *Velocity* – Select the desired units of measure: fpm or m/s

Once the selection is made, touch **[OK]**.

Activating the Security Lock

Touch **[Security]**. Security codes can be set to limit access or prevent modification to certain areas of the cabinet control system. Supports two PINs (User and Admin), that can be set in this menu. Select the areas of the cabinet that are desired to be password protected. If User is selected, Admin is automatically selected as well. If *'System'* is selected to require a security code, the applicable PIN is needed upon wake from sleep screen and the Display Screen Timeout cannot be *'Never'*. After any features are selected to be password protected, the *Security Enabled* toggle must be set to enable.

Figure 6-7

	User	Admin
System	<input type="checkbox"/>	<input type="checkbox"/>
Data Logging	<input type="checkbox"/>	<input type="checkbox"/>
Network	<input type="checkbox"/>	<input type="checkbox"/>
Email Alerts	<input type="checkbox"/>	<input type="checkbox"/>
Configuration	<input type="checkbox"/>	<input checked="" type="checkbox"/>
Maintenance	<input type="checkbox"/>	<input type="checkbox"/>

Security Enabled:

SET USER PIN SET ADMIN PIN

BACK



The Default PIN is '1 2 3 4' for User, and '1 9 2 5' for Admin. The PIN can be changed by pressing **[SET USER PIN]** or **[SET ADMIN PIN]** as shown in Figure 6-7.



There is no PIN recovery function. If the PIN is forgotten, you cannot access the touchscreen controls.

Setting the Data Acquisition Rate

Touch **[Data Logs]**. This screen provides settings for the data log functionality.

- *Data Acquisition Rate* – The available rates are 10s, 30s, 1min, 2min, 3min, 5min & 10min.
- *Log File Deletion* – Saved data logs delete after this time. Deletion rate options are 1, 3, 6, or 12 months (1 year) with 1 year being the default value.

Adjusting the Display

Touch **[Display]**. Provides settings for the display screen functionality.

- *Brightness Slider* – Adjust the display brightness by dragging the bar *left/right*.

- **Screen Timeout Function** – If enabled, the screen will go to sleep (low power mode) when no screen touches have been detected for the allotted time (defined in the **Screen Timeout** dropdown menu). If the blower is ON, the screen will dim. If the Blower is OFF the screen will go off. Touching the Screen Timeout Function toggle changes between ON & OFF.
- **Screen Timeout** – This value can be set to **5, 10, 15, 30 min**, and **1, 2, 3 hours** or **Never**.



Turning off the *Screen Timeout Function* can decrease the screen life.

Utilizing Network Connection

Touch **[Network]**. Modify Network connection specifications, if an active ethernet connection has been established.

The most common setting for network connectivity via an Ethernet port is **DHCP Enabled**. This setting allows the facility’s network to dynamically assign an IP address. Reference Figure 6-8. Touch the toggle next to **DHCP Enabled** to change between enable / disable. When enabled, the remaining fields will be grayed out, as these will be assigned by the facility’s network. If the field next to **IP Address** is populated with four sets of numbers (each separated by a period), and a green “**Active connection detected**” is displayed the cabinet has successfully received an IP address from the network. A red “**No active connection detected**” will be displayed if no connection is found. Please consult your IT department for additional assistance.

If a static IP address must be assigned by your facility’s IT department, set the **DHCP Enabled** toggle to Disable. Contact your IT department for the appropriate information to enter in the remaining fields.

Figure 6-8

Activating Email Alerts

Touch **[Alerts]**. If a valid network connection has been established and Network settings have been properly configured, (via the **Network screen**) alerts can be emailed to selected users, by entering the appropriate email address(es) and selecting the type of

alerts to be sent to each email address. To enable e-mail alerts, follow these instructions:

Each cabinet requires its own email address. Before proceeding, set up an email address for each cabinet. The e-mail account can be any free service (i.e. gmail.com, outlook.com, etc.) or a company's hosted domain (i.e. xyzlabs.com).

Once the e-mail account(s) are set up, obtain the following information for each account (e-mail address):

- SMTP Server
- SMTP Username
- SMTP Password
- SMTP Port Number
- Encrypted Connection

Here is an example (this information will not be correct for your e-mail account) set-up for fake e-mail account: Cell Logic123@gmail.com

- smtp.gmail.com
- Cell Logic123
- cat@ndmouse457
- 587
- Enable

Select the *Gears icon* (shown in Figure 6-9) and a settings pop-up will display. After entering the appropriate information for the cabinet's email address in all fields, touch **[SAVE]**. The system will check valid formatting only. If one or more invalid entries are found the following message will appear: *Email Settings Error*. Correct the error and retry.



If all the SMTP fields entered are valid, but the network connection is not working (or Ethernet cable is not connected) the message “*Email Settings Error – Network connection is not active*” will appear. Resolve the connectivity problem and retry.

To add a user's email to receive e-mail alerts from the cabinet:

- Touch the *Plus* icon at the lower right corner of Figure 6-9 to add an email address.
- Enter your e-mail address, touch **[DONE]**.

Figure 6-9

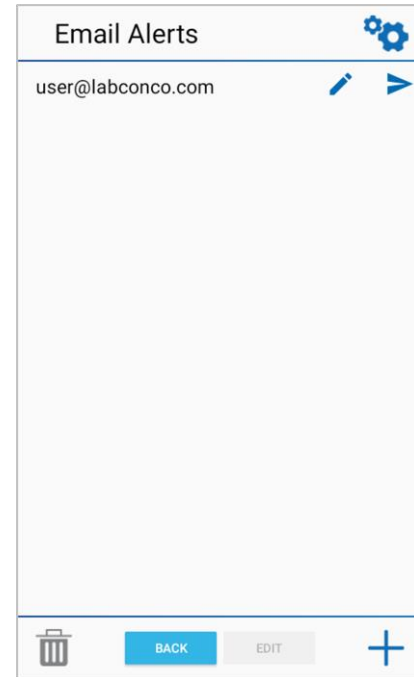

To test the user's email:

- Touch **[SEND TEST]** (represented by the paper airplane) next to the desired e-mail address. (If all information is correctly entered, a test email from the cabinet will be sent.)

Once the SMTP Settings (for the cabinet's e-mail address) have been correctly entered, and the notification e-mail address (e-mail address for who is receiving the notifications) has been correctly entered and tested, the final step is to select the alerts to send to each e-mail address. Follow these instructions to select alerts:

1. Touch **[EDIT ALERTS]** (represented by the pencil) next to the email address. The Alert options are the same as detailed in Table 6-1 of this section. A pop-up will display the alert options.
2. Select the desired alerts. Touch **[OK]**.

To delete a user's email:

- Touch the e-mail address to delete, it will highlight.
- Touch the **[DELETE]** icon shaped like a trash can in the bottom left corner of the screen (reference Figure 6-9).

Adjusting Maintenance Reminders

Touch **[Maintenance]**. The cabinet records the time the filters, LED lamps and UV lamp (if applicable) are in use. These timers are used to automate reminders for the replacement of consumable components at the intervals set by the user. The default values for each reminder are shown in Figure 6-10 under '*Reminders*'. The value next to each adjustable time is the time remaining before a reminder alert.

Once the component time remaining reaches 0, a pop-up to replace that component will appear. If the user selects **[REMIND ME LATER]** on the pop-up, the user will be prompted to replace the component after an additional 4 hours of use. If the component

is replaced, select **[SERVICE COMPLETE]** and input the name of the servicer, date and event in the *Certifications Records* pop-up. The reminder time will start over. If **[RESET]** is selected from the maintenance menu, the user will still have to input their name, date, and event into the *Certifications Records* pop-up before the reminder timer will start over.

Figure 6-10

The screenshot shows a 'Maintenance' menu with the following sections:

- Lifetime Count (Hours):**
 - Filtration Blower: 0
 - Light: 0
 - UV Light: 0
- Reminders (Hours):**
 - Change Light: 20000 (with a 'RESET' button below it)
 - Change UV Light: 6000 (with a 'RESET' button below it)
- Recertify Airflow (Months):** 12
 - Last: 01/18/2024
 - Due: 01/18/2025
 - (with a 'DECON' button below it)

A 'BACK' button is located at the bottom of the screen.

The Certification Submenu

Touch **[Certification]**. This submenu is reserved for use by certifiers during certification or service procedures.



CAUTION! - Entering this submenu will disable some alarms and functionality so that diagnostic and certification procedures can be performed.

Additional details can be found in the Logic Technical Manual.

Navigating the Help Menu

To access the *Help Menu* from the *Home Screen*, press **[Help]** (represented by the question mark icon) on the Menu Bar of the display. The display will change to the *Help Menu* (see Figure 6-11). To return to the *Home Screen*, press **[Home]** along the same Menu Bar. The *Help Screen* contains several useful submenu icons. The sub-menus are described briefly below.

- *About* – Provides unit specific information (Catalog Number, Serial Number, Software Version). Software updates via USB or Ethernet can be performed from the About page.

- **Sensors** – Displays the current sensor reading in the selected unit of measure.
- **Diagnostics** – Used to test the cabinet operation/components after installation or should a problem occur.
- **Resources** – Provides consumable information.
- **Notifications** – Provides an event history, similar to the *Data Log*, excluding the routine operation data. Events include alarms, alerts, reminders, and other serviceable information.

Figure 6-11

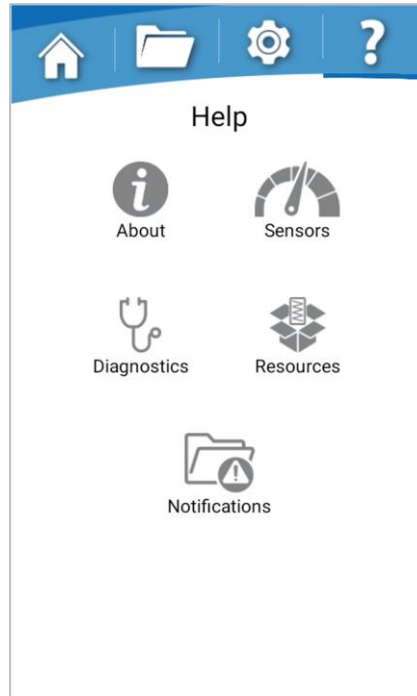

About

Displays Operating System information such as the software version, the Catalog Number and Serial Number. System updates via USB or an ethernet connection can be performed from the **About Screen**. Reference Figure 6-12.

Figure 6-12

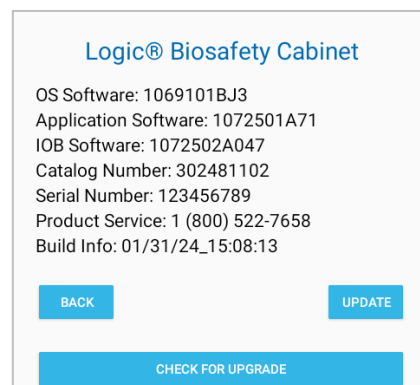

Software Update via USB Thumbdrive

To update the software via USB, you must first download the latest version, available at Labconco.com to a USB thumbdrive.

- The blower must be shut off prior to updating.
- With the proper software file on a thumbdrive, insert it into the USB Port on the front of the cabinet to the right of the Display.
- A pop-up will prompt you to allow the software to access the files on the thumbdrive. This is a security feature of the Android-based software. You must touch **[OK]** to continue.



The thumbdrive must be properly formatted as **FAT32**. If it is not, the update process will not proceed, and you will receive a pop-up instructing you that the drive is not properly formatted. If this occurs, you must reformat the thumbdrive using a PC or laptop to FAT32. For Windows users, you must select “**FAT32**” when formatting the thumbdrive, and not “**FAT32 (default)**”.

- Touch the **[UPDATE]** button on the *About* screen. Select the software file on the pop-up that appears; touch **[OK]**.
- The update will begin, and the screen will not allow interaction until the process is complete.
- The system will notify you when the upload is complete and successful. Touch **[Install]**. Touch **[Open]**.
- The *Home Screen* will appear with a Power Loss Alarm. Press the **[OK/MUTE]** key. Update is complete. Remove the thumbdrive from the USB port.



Do not remove power during the update process. If power is lost, the software may be corrupted, and the cabinet will be inoperable.

Software Update via the Ethernet

To update the software via the ethernet, you must first have an active connection.

- From the *About Screen*, touch **[CHECK FOR UPGRADE]**.
- If available, the *Upgrade Available* screen will display and allow you to ignore, postpone or update now.
- Pressing the **[RELEASE NOTES]** will allow you to review the changes.
- If available and you would like to update, select **[UPDATE NOW]**.

Automatic Update Notification

To Program the cabinet to notify you if upgrades are available, the system must have a valid ethernet connection.

- From the *About Screen*, touch **[CHECK FOR UPGRADE]**.

- At the *Upgrade* screen touch **[CONFIGURE]** and select *Automatically check for updates* and **[OK]**.

Once enabled, the *Upgrade Available Screen* will popup when new software becomes available.

Sensors

This screen contains a list of all sensors installed on the Cell Logic. The *Sensors Screen* displays the current sensor reading in the selected unit of measure. This screen is for viewing only (there are no selectable fields). Reference Figure 6-13.

Figure 6-13

Sensors	
NAME	VALUE/STATE
Blower	0 rpm
Light	OFF
UV Light	OFF
Outlet	OFF
Sash	Off Working Height
AFS, INFLOW	
Current	0 fpm
Current Raw Output	972 mV
Nominal Calibration @	1403 mV
Notification Calibration @	1230 mV
AFS, DOWNFLOW	
Current	0 fpm
Current Raw Output	967 mV

Notifications

The *Notification History Screen* provides a history, similar to the *Data Log*, excluding the routine operation data (i.e., Light status, Blower in Night-Smart, etc.). Notifications descriptions are listed with the date and time of the event's occurrence and can include alarms, alerts, reminders, and other serviceable information. The history can be sorted for the user's convenience by most recent first, most recent last, and alphabetically by touching the drop-down arrow above the occurrence column. All *Notification History* can be exported to a flash drive by touching **[Export USB]**. Reference Figure 6-15.

Figure 6-15

Notification History	
Description	Recent Top ▼
⚠ Power Loss	Jan 31, 2024 03:12 PM
⚠ Power Loss	Jan 31, 2024 01:39 PM
⚠ Blower Failure	Jan 31, 2024 09:04 AM
⚠ Sash out of position	Jan 31, 2024 09:04 AM
⚠ Blower Failure	Jan 31, 2024 08:48 AM
⚠ Blower Failure	Jan 31, 2024 08:47 AM
⚠ Blower Failure	Jan 31, 2024 08:28 AM
⚠ Sash out of position	Jan 31, 2024 08:27 AM
⚠ Blower Failure	Jan 31, 2024 08:02 AM
⚠ Blower Failure	Jan 31, 2024 07:56 AM

BACK EXPORT USB

Timer Operation (Optional)

There is a timer option that can be enabled and disabled by a setting in the *Configuration Screen*. The timer counts down from the set point selected and chimes once the time is zero. To adjust the status of the timer, see *Settings>Configuration* of this section and Figure 6-16. To change the timer chime, see *Settings>Display* of this section for more information.

If enabled, the timer can be found in the bottom left corner of the *Home Screen* as shown in Figure 6-1. To change the timer length, touch the **[Timer Value]**. To start or pause the timer, touch **[Play/Pause]**. To restart the time to the max set value, touch **[Reset]**. Reference Figure 6-16.

Figure 6-16

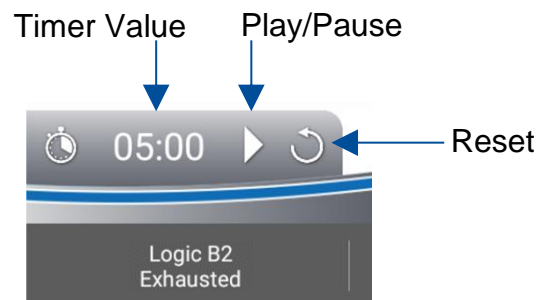

The timer can also be initiated, stopped or reset using the **[TIMER]** key on the keypad. The timer value must be set on the touchscreen display, but each press of the **[TIMER]** key starts, stops and resets the timer (respectively).

Alerts

When an Alert activates, an audible alert tone will sound and the display will show the alert cause. All alerts are mute-able and will auto-dismiss once the alert is resolved.

Airflow Blockage

While the blower is on, any sudden disruption to the airflow within the cabinet will trigger an Airflow Alert. When an Airflow Alert activates, the display will automatically change (Figure 6-17), and the audible alert tone will sound. The most common causes of an Airflow Alert are:

- Blockage of the inlet grilles or exhaust outlet.
- Removal of the work surface or grille during operation.

Figure 6-17

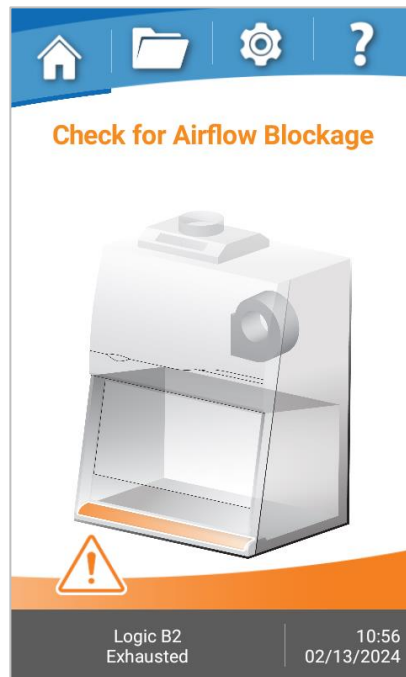

Look to identify the cause of the airflow disruption, and remove the blockage or return the work surface to its proper position.



When a blockage of the airflow occurs, the cabinet's blower automatically increases its speed to maintain constant volume airflow. This is a protective feature; however, if the disruption is significant (for example blocking the entire front grille) it will not guarantee product or personnel protection remains during the significant blockage event.

Resetting the Airflow Blockage Alert System

The Airflow Alert automatically dismisses once the motor speed has stabilized.



Note: Once the blockage or disruption has been resolved, the Airflow Alert may reactivate while the blower returns to correct operating speed. It will dismiss automatically once the blower reaches correct operating speed.

Exhaust Airflow Check

This alert appears (see Figure 6-18) when the cabinet's blower is desired on from an off state and the exhaust airflow is not above the alarm set point. It will auto dismiss if the required exhaust airflow is supplied before the Exhaust Start Delay has elapsed. If required exhaust is not provided to the cabinet in the delay time, the Exhaust Failure Alarm (reference Alarms of this Section) will occur.

Figure 6-18

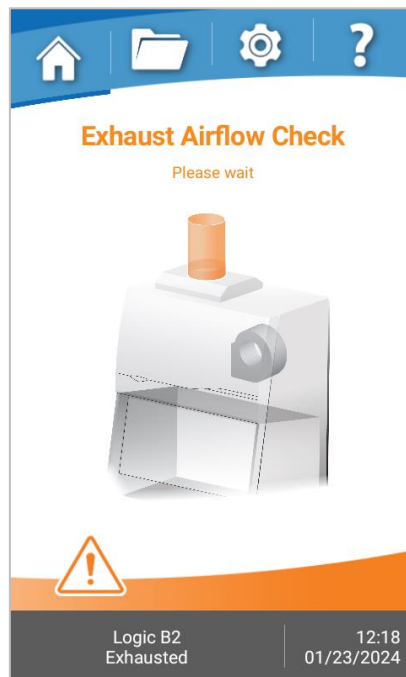

Alarms

Any alarm that activates requires the user's immediate attention, and some form of actionable response to clear the alarm.

Power Loss Alarm

The cabinet has lost power. See Figure 6-19. Press [OK] on the keypad to acknowledge that a power loss occurred.

Figure 6-19



Note: This alarm will activate any time power is cycled, including turning the System Reset Switch (see Figure 7-2) off and back on.



Sash Height Alarm

The sash is not at the proper operating height when the blower is on. Return sash to proper working height.

Figure 6-20

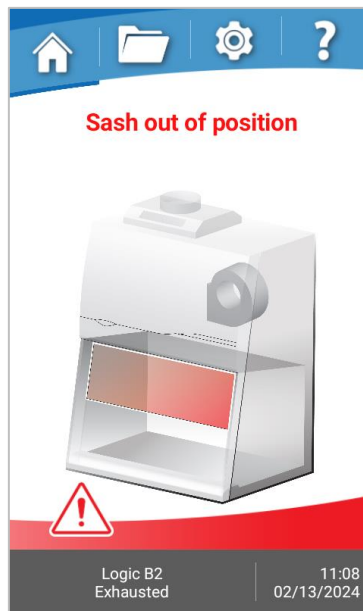

Memory Failure

The internal memory storage has failed. The calibration settings may be compromised. Contact Service before use. Press **[OK]** on the keypad to acknowledge that a memory failure has occurred.

Figure 6-21

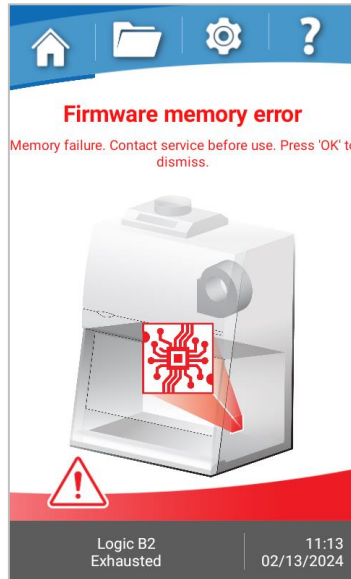

DO NOT USE THE CABINET UNTIL THE PROBLEM HAS BEEN CORRECTED.

Blower Failure Alarm

The blower motor has failed, or the motor and display circuit board are not communicating properly. Press **[BLOWER]** on the keypad to clear the alarm.

Figure 6-22



DO NOT USE THE CABINET UNTIL THE PROBLEM HAS BEEN CORRECTED.

Exhaust Failure Alarm

When operating after the blower is successfully started and the building exhaust airflow drops below the minimum safe level or if sufficient exhaust airflow is not detected within the Exhaust Start Delay Time period, this alarm will be displayed. Reference Figure 6-23.

Once this alarm activates, the cabinet's blower will turn off (if in operation).

Press **[BLOWER]** on the keypad to dismiss this alarm.

Figure 6-23

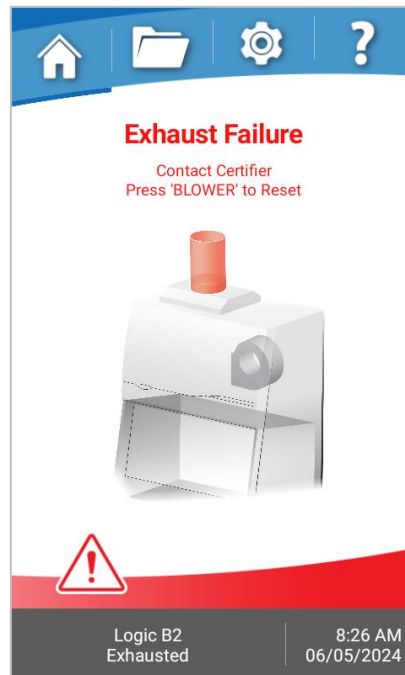

7: Using Your Cell Logic Type B2

This section details the functional features and proper techniques for safely and efficiently using the Cell Logic Type B2 biosafety cabinet.

Feature Overview

Figure 7-1 illustrates key features and components of the product.

Figure 7-1

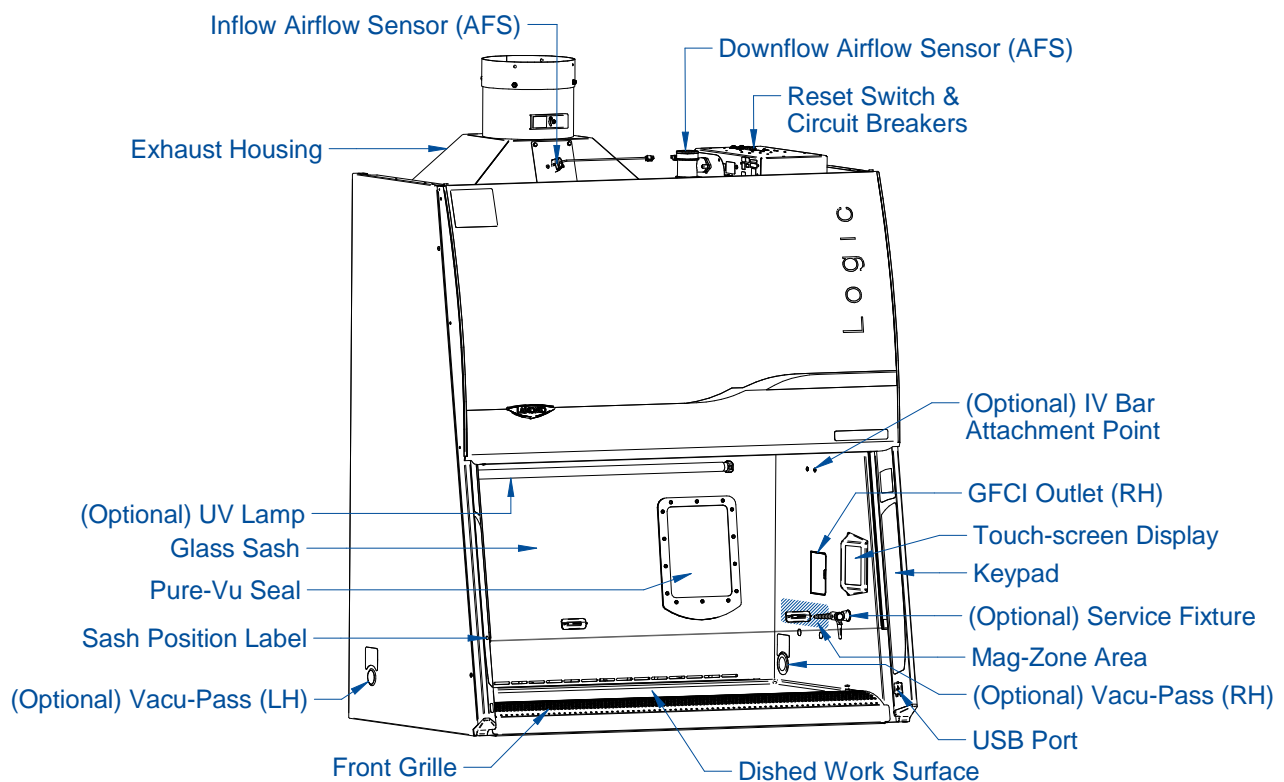

System Reset Switch

The system reset switch removes power from the control board and microprocessor. It is located on the top face of the electrical box on the rear, right side of the product. See Figure 7-2. This switch will NOT remove all electrical power from the product. For service operations, always disconnect the main electrical connection prior to removing service panels.

Figure 7-2

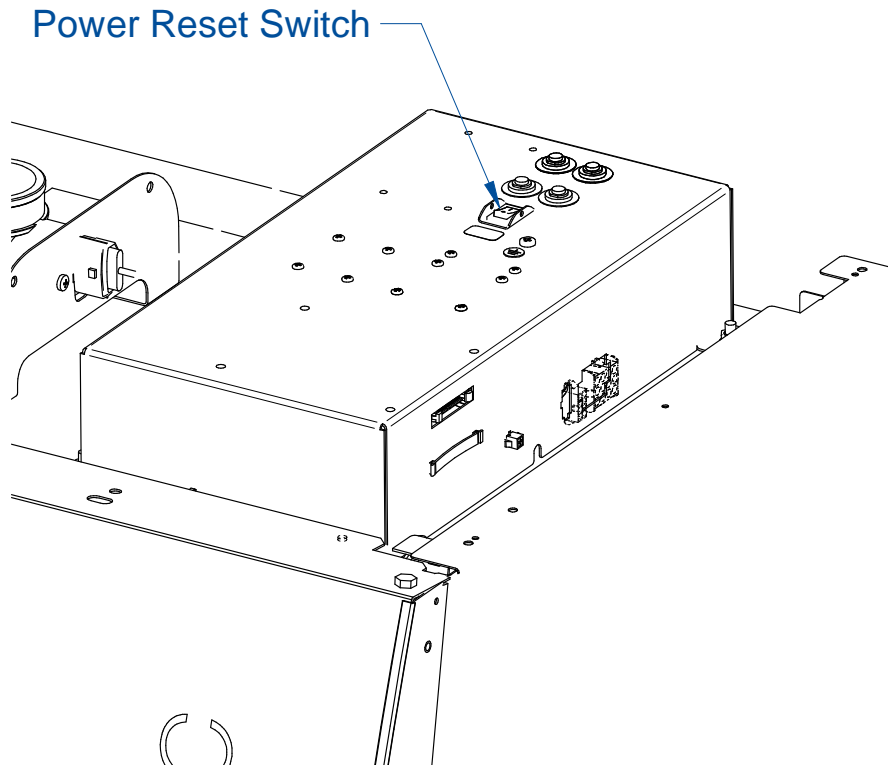

Keypad

The keypad of the cabinet is shown in Figure 7-3. Take a moment to familiarize yourself with the buttons, their locations and functions. Also familiarize yourself with the display located on the right side wall. The display will report system functions, such as filter capacity, timer displays, alarm or error messages, as well as icons that illuminate when cabinet functions such as the light and blower are operational.

[BLOWER] – Starts or stops the cabinet blower. When the blower is in automatic (Smart-Start™) mode, opening the sash from the closed position turns the blower on automatically. Pressing the blower button at any time overrides the automatic operation.

[LIGHT] – Turns the LED lamps on or off. Closing the sash automatically turns the lights off. When the lights are in automatic (Smart-Start) mode, raising the sash turns the lights on automatically. Pressing the light button at any time overrides the automatic operation.

[OUTLETS] – Turns on/off electrical outlets in the work area.

[UV LIGHT] – Turns on/off the UV lamp (when installed). When the UV lamp is in automatic mode, closing the sash turns the UV light on automatically. When the sash is raised, the UV light turns off automatically. Sash must be closed for operation.

[TIMER] – Allows you to control (play, pause, and reset) the optional Timer on the Home Screen.

[OK/MUTE] – Mutes all audible alarms for approximately 5 minutes, unless there is a system error alarm. When in *Certification*, this button is used to select an option.

[UP] and **[DOWN]** – Moves between selectable options or change numerical fields in *Certification*.

[TOUCH] – Turns on/off the touch screen capabilities of the display.

Figure 7-3

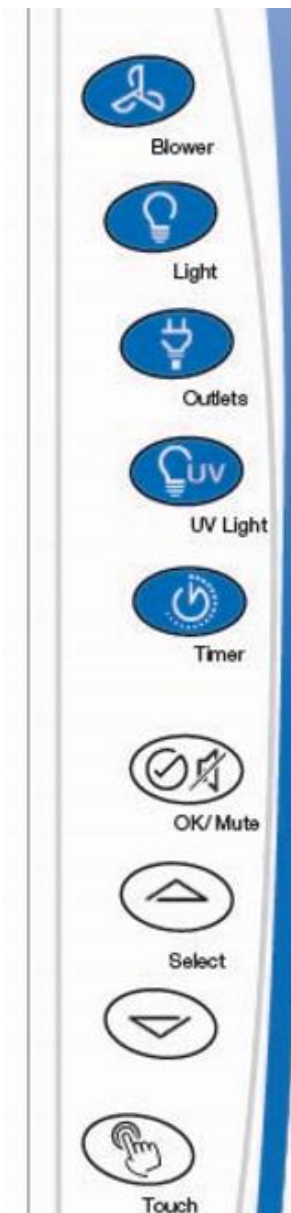

Sash Operation

The counterbalanced, anti-racking sash mechanism requires only a few pounds of force to move the sash up or down. You can open or close the sash smoothly with one or two hands positioned on either handle.

The sash position alarm and safety interlock system senses the sash position and acts appropriately. An audible sash sound will occur when the interlock system senses the sash is at operating height. The cabinet has been programmed to operate at an 8-inch (203 mm) sash opening. When the Blower is ON, moving the sash above or below its operating height will activate the audible and visual alarms. The audible alarm can be temporarily muted for approximately five minutes by pressing the **[OK/MUTE]** button on the Keypad. Moving the sash back to its operating position will reset the alarm. The safety interlock system senses when the sash is closed and allows the optional UV lamp to operate only when the sash is closed, to protect the operator from irradiation.

Blower Operation

The Cell Logic Type B2 biosafety cabinet can be configured to automatically turn on the internal blower via Smart-Start. If this feature is enabled, raising the sash from closed to operating height will automatically turn on the blower. If this feature is not enabled, raise the sash to operating height, and press **[BLOWER]**. Either method will start the blower, and the *Airflow Status* will read *Wait* for approximately 1 minute.

If the facility's remote blower, or exhaust system, connected to the cabinet is not pulling the required volume of exhaust air through the exhaust housing, the internal blower will not start. If the building exhaust system does not reach the required minimum volume of airflow within 60 seconds of pressing **[BLOWER]**, an exhaust alarm will occur.

Light Operation

The Cell Logic Type B2 biosafety cabinet provides dual LED lamps for illuminating the work surface. The cabinet can be configured to automatically turn on the LED lighting via Smart-Start. If this feature is enabled, raising the sash from closed to operating height will automatically turn on the LED lighting. If this feature is not enabled, raise the sash to operating height, and press **[LIGHT]**. Either method will illuminate the LED lighting.

Outlet Operation

The Cell Logic Type B2 biosafety cabinet provides two GFIC outlets with a maximum total amperage draw of 5A (100-115v models) or 3A (230v models). Power to the outlets can be activated or deactivated from the Keypad. To activate or deactivate power to the outlets, press **[OUTLET]**.

Vacu-Pass™ Cord & Cable Portal (optional)

The Vacu-Pass allows for passage of a cord, cable, or tube from within the product. The pass-through provides a sealed plug, and the plug housing is maintained under negative pressure to safely pass cords through the right side wall of the product. Not all models are configured with Vacu-Pass ports, if your model does not contain this option, this section may be skipped.



Some Vacu-Pass components and the cord passing through it may become contaminated during use of the cabinet. Ensure all potentially contaminated components are surface decontaminated before handling or removal from the cabinet.

1. Remove the grommet from the liner side wall. Remove the pre-cut plug from the body of the portal by either pressing it through from the outside, or by carefully inserting a spatula or similar device between the sealing plug and the body of the portal, and prying the plug out.
2. If running the cord or cable through the portal on the side panel, remove the portal cap. If needed, carefully insert a spatula or similar device under the perimeter of the portal cap to pry it out. Pass the cord or cable through the side panel portal to the pre-cut plug.
3. If running the cord or cable up or down under the side panel, leave the portal cap installed. Pass the cord or cable behind the paneling as needed to the pre-cut plug.
4. Pass the cord or cable through one of the pre-cut plug holes, then through the grommet, as shown in Figure 7-4.

Note: Select a pre-cut plug hole that is slightly smaller than the cord or cable, to create a proper seal. The pre-cut plug has a core piece that must be removed before inserting the cord.

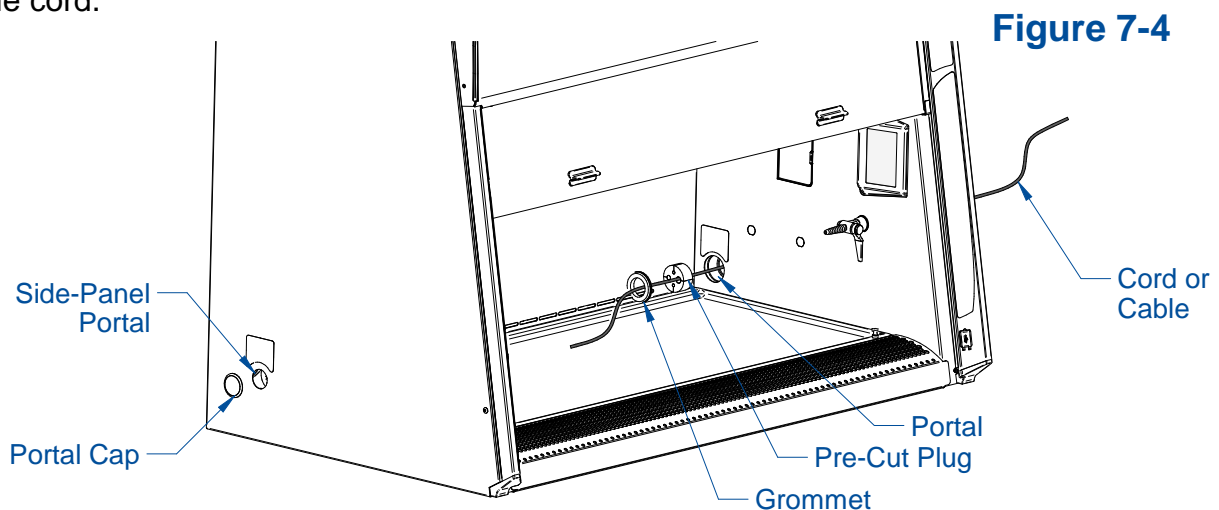

5. Position the cord or cable as it will be used in the cabinet, and then push the plug back into the body of the portal until it seats in the portal. Reinstall the grommet.

Working in the Cabinet

Working in the Cell Logic Type B2 biosafety cabinet requires preparation, planning, and an understanding of aseptic technique to work safely. The steps below represent the minimum requirements before, during, and after working in a biosafety cabinet. Consult your Health & Safety department for additional SOP requirements.

Planning

1. Thoroughly understand procedures and equipment required before beginning work.
2. Arrange for minimal disruptions, such as room traffic or entry into the room while the cabinet is in use.

Cabinet Start-up

1. Turn off UV light (if included on your cabinet).
2. Slowly raise the sash until the bottom of the sash aligns with the sash indicator decal located on the left side of the work area.
3. Turn on the light and cabinet blower if the automatic features have not been enabled.
4. Check the air grilles for obstructions.
5. Allow the cabinet to operate until the **Airflow Status** on the *Home Screen* says 'OK'

Figure 7-5

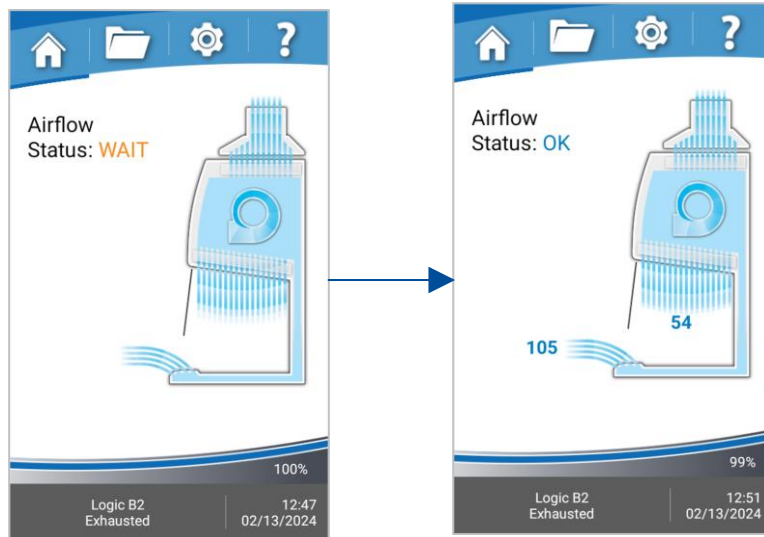

6. Wash hands and arms thoroughly with germicidal soap.
7. Wear appropriate personnel protective equipment (PPE).

Wipe Down

1. Raise the sash to its full open position (approximately 22.5 inches or 571 mm). Mute the alarm by pressing **[OK/MUTE]**.
2. Wipe down the interior surfaces of the cabinet with 70% ethanol, or a suitable disinfectant, and allow to dry.

Loading Materials and Equipment

1. Only load the materials required for the procedure. Do not overload the cabinet.
2. Do not obstruct the front, side, or rear return air grilles.
3. Large objects should not be placed close together.
4. Slowly close the sash until it is in the correct operating position.
5. After loading the cabinet, wait two to three minutes to purge airborne contaminants from the work area.

Work Techniques

- Keep all materials at least 4 inches (100 mm) inside from the sash, and perform all contaminated operations as far to the rear of the work area as possible.
- Segregate all clean and contaminated materials in the work area.
- Arrange items to minimize movement of contaminated materials into clean areas.
- Keep all discarded contaminated material to the rear of the work area.
- Avoid moving materials or the operator's hands and arms through the front access opening during use.
- Avoid the use of an open flame. Use disposable labware or an electric incinerator as alternatives.
- Use proper aseptic technique.
- Avoid techniques or procedures that disrupt the airflow patterns of the cabinet.
- If there is a spill or splatter during use, all objects in the cabinet should be surface decontaminated before removal. Thoroughly disinfect the working area of the cabinet **WHILE IT IS STILL IN OPERATION**, to prevent the release of contaminants from the cabinet.

Final Purging

- Upon completion of work, the cabinet should be allowed to operate for two to three minutes undisturbed, to purge airborne contaminants from the work area.

Unloading Materials and Equipment

- Objects in contact with contaminated material should be surface decontaminated before removal from the cabinet.
- All open trays or containers should be covered prior to removal from the cabinet.

Wipe Down

1. Wipe down the interior surfaces of the cabinet with a suitable disinfectant, or 70% ethanol, and allowed to dry.

2. Periodically lift the work surface and wipe down the area beneath it.
3. Inspect and clean the towel catch located at the rear of the work area, beneath the work surface.
4. Dispose of rubber gloves appropriately, and have lab coat laundered properly.
5. Wash hands and arms thoroughly with germicidal soap.

Shutdown

- Lower the sash and turn off the light and cabinet blower. Activate the UV light, if installed and required.

8: Maintaining Your Cell Logic Type B2

This section details normal maintenance required for optimal operation of the Cell Logic Type B2 biosafety cabinet. This section does not cover service operations beyond normal maintenance, nor does it cover annual airflow certification procedures. These advanced sections are found in the Logic Technical Manual.

Maintenance Safety Precautions

The following tools and supplies are required to maintain the equipment:



- #2 Phillips Screwdriver
- 70% alcohol solution (or other approved surface disinfectant)
- Paper Towels



The following safety precautions must be followed by all personnel maintaining the equipment.

- Wear safety glasses, and/or additional eye and face protection as required by your Health & Safety Department.
- Wear gloves, and/or additional skin protection as required by the safety instructions for the specific cleaning/disinfecting chemicals used. Consult your Health & Safety Department for additional skin protection requirements.
- No loose fitting clothes
- Wear close-toed shoes
- Although the service operations detailed in this section do not involve access to areas of the product with moving or electrical parts, should you remove any panels that expose moving or electrical parts, you must follow these instructions before doing so:
 - Disconnect main power cord or electrical service connection
 - Never touch moving parts such as fan blades or blower wheels.
- Never touch the HEPA (or ULPA) filter media. Touching the media will damage it, and result in a failure of the filter to function properly and maintain safe conditions.



Recommended Maintenance Schedule

Table 8-1

Activity	Maintenance Frequency		
	Weekly	Monthly	Annually
Disinfect interior surfaces (with suitable chemical disinfectant)	•	•	•
Wipe down interior surfaces after contact time elapsed with 70% alcohol solution	•	•	•
Clean sash glass and UV lamp with suitable glass cleaner	•	•	•
Operate cabinet blower, noting Filter Life percentage in log	•	•	•
Using 70% alcohol solution, wipe down cabinet exterior		•	•
Disinfect and lift work surface. Surface disinfect the area beneath with suitable chemical disinfectant		•	•
Wipe down area beneath work surface after contact time elapsed with 70% alcohol solution		•	•
Check all service valves (if equipped) for proper operation		•	•
Check the UV Lamp Hour meter, noting in log (if equipped)		•	•
Inspect/replace the supply pre-filter on top of the cabinet			•
Have the cabinet recertified by a qualified technician			•

Service Operations

The operations in this section provide instructions to maintain the Cell Logic Type B2 for normal consumable replacement, and access to parts in accordance with the Recommended Maintenance Schedule. This section does not cover service operations beyond normal maintenance, nor does it cover annual airflow certification procedures. These advanced sections are found in the Logic Technical Manual.

Resetting a Circuit Breaker

Should an over current situation arise during normal operation, the circuit breakers located on the top side of the top electrical box will trip, protecting the cabinet from damage.

The Cell Logic Type B2 biosafety cabinet offers internal outlets to power small devices inside the cabinet. The internal outlets are protected by one circuit breaker (two circuit breakers on 230v models), and the cabinet electronics are protected by a different circuit breaker (two different circuit breakers on 230v models). This allows the cabinet to continue to operate, providing protection to the product and user, should a device connected to an internal outlet experience an over current situation.

If the internal outlets do not have power when the Outlet icon is displayed on the Home Screen, reset the appropriate circuit breaker(s) as shown in Figure 8-1. The outlet circuit breaker(s) are in the Right-Hand Position(s).

If the cabinet does not have power when the System Reset Switch (Figure 7-2) is on, reset the appropriate circuit breaker(s) as shown in Figure 8-1. The cabinet circuit breaker(s) are in the Left-Hand Position(s).

The thrown circuit breaker will be easy to identify, as the white barrel will be extended further than the other circuit breaker(s). To reset, simply push it in.

**Cabinet Circuit Breakers
(Left-Hand Position)**

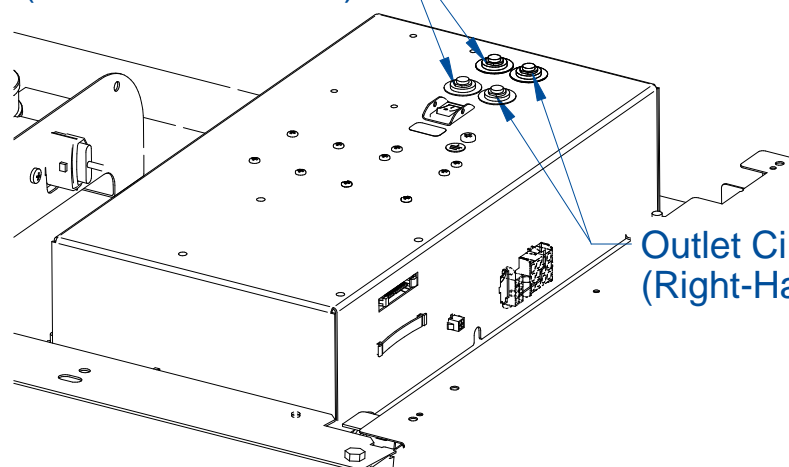

Figure 8-1

**Outlet Circuit Breakers
(Right-Hand Position)**

Cleaning Beneath Dished Work Surface (Temp-Zone™ Only)

To lift or remove the dished work surface, reference Figure 7-1 for part identification and follow these steps.

1. Turn the cabinet blower on.
2. Lift the front edge of the work surface up by grasping the knob at either front corner.
3. If removal of the work surface is not necessary, skip to Step 4. To remove the work surface, pull the work surface straight out, letting the rear edge rest on the center support underneath the work surface.



If removing the dished work surface from the cabinet, the work surface must be thoroughly decontaminated before removing it from the cabinet.

If removing the work surface support bracket/prop rod, compress the sides of the support bracket and lift up off the drain pan pins. Reference Figure 8-2.

If reinstalling the work surface support bracket/prop rod, ensure the arrow etched on the part (Reference Figure 8-2) is always facing towards the front of the cabinet. There are two sets of holes on the work surface support. When reinstalling the support, use the back set if there are service fixtures installed in the side walls of your cabinet. If there are no service fixtures, the front set of holes can be used. Reinstall by compressing the base of the support on either side and sliding down on the drain pan pins.

Figure 8-2

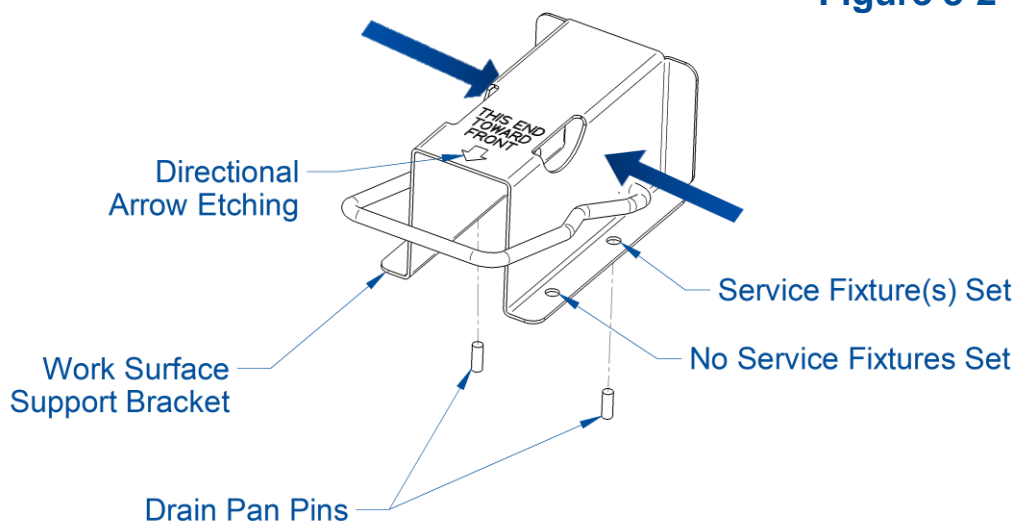

To reinstall the dished work surface, rest the bottom of the work surface on the center support while pushing it back into the cabinet. Be sure to engage the tabs on the back corners of the work surface with the slots on the rear wall of the work area.

4. With the work surface front lifted, locate the wire-formed prop rod, and rotate it up to rest against the back flange of the work surface support bracket. Reference Figure 8-3.
5. Carefully lower the work surface onto the prop rod and release when stable. Do not release the work surface if the prop rod is not fully in place against the support bracket.

Figure 8-3

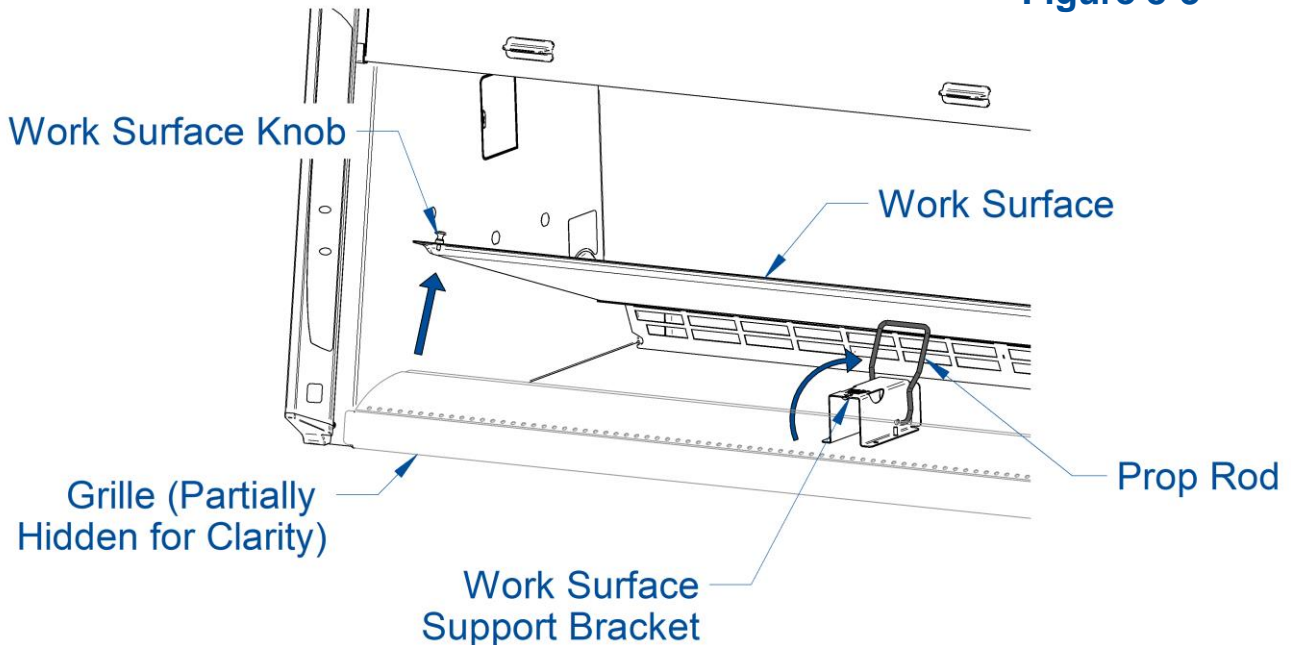

The dished work surface on a Temp-Zone model can also be secured in an elevated position via the Easy-Clean™ prop rod system. Reference Figure 4-10.

Cleaning Beneath Dished Work Surface (Scope-Ready™ Only)

To remove the dished work surface, reference Figure 7-1 for part identification and follow these steps.

1. Turn the cabinet blower on.
2. Lift the front edge of the work surface up by grasping the knob at either front corner.
3. To remove the work surface, pull the work surface straight out, letting the rear edge rest on the center support underneath the work surface.



If removing the dished work surface from the cabinet, the work surface must be thoroughly decontaminated before removing it from the cabinet.

To reinstall the dished work surface, rest the bottom of the work surface on the center support while pushing it back into the cabinet. Be sure to engage the tabs on the back corners of the work surface with the slots on the rear wall of the work area.

Front Grille Removal

Before beginning, the dished work surface must be securely lifted or removed, as described previously. Reference Figure 7-1 for parts identification.

1. If not already on, turn the cabinet blower on.
2. Grasp the front grille with two hands, one on the inside edge and one on the outside edge. Pull the front grille up, while also rotating the top slightly inward.



Note: It may be difficult to raise the front grille at first. If so, move to one end of the front grille, and follow step #2 while also rotating the grille up on that end. Once one end has raised slightly, then move back to the middle and continue to lift it up.



If removing the front grille from the cabinet, the front grille must be thoroughly decontaminated before removing it from the cabinet.

Front Panel Removal

Removal of the front panel is only necessary to change the LED lamps.



Tools Required:

- #2 Phillips Screwdriver



It is recommended to utilize at least two (2) persons to remove the front panel, particularly for a 6-ft model. The front panel is heavy. Take care to use safe lifting practices, and to set the panel where it cannot fall over while uninstalled from the cabinet.



Before removing the dress panel, remove all electrical power to the cabinet by disconnecting the power cord from the cabinet.

1. Locate and remove the two Phillips screws that secure the front panel as shown in Figure 8-4. They are located on the bottom corners of the front dress panel.
2. Swing the bottom of the dress panel out to clear the LED lamps and then lift the front dress panel straight up and away from the cabinet.

Figure 8-4

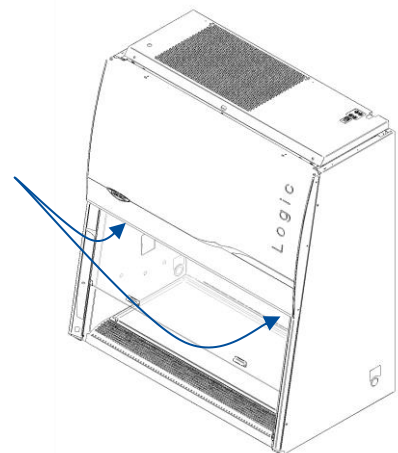

To reinstall the panel, reverse these steps, ensuring that the plastic pins in the top corners of the front dress panel are properly engaged in the top of each corner post.

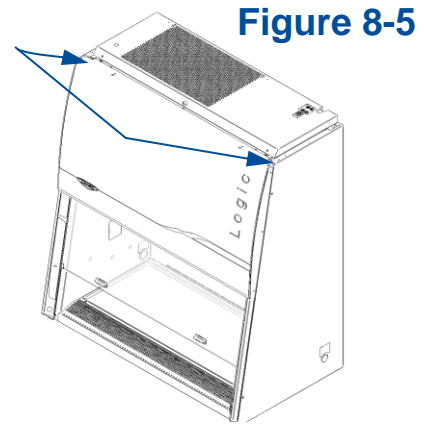

Changing the LED Lamps



Before proceeding, make sure all electrical power has been removed from the cabinet by disconnecting the main electrical connection, which is the power cord.



This product uses only LED direct drive lighting. Do NOT install fluorescent bulbs.

1. Remove the dress panel as noted in Figure 8-4.
2. Locate the Left End Cap that aligns both LED lamps (Figure 8-6), remove the Left End Cap by pulling it away from the lamp ends.

Figure 8-6

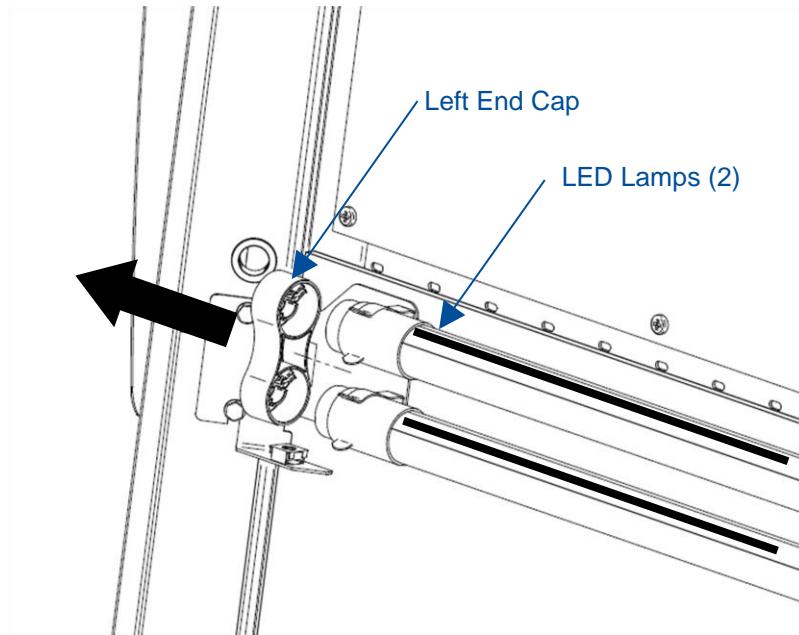

3. Remove both Socket Caps (on the right end of each LED lamp) by pulling each Socket Cap straight off the right end of the lamp one at a time (Figure 8-7).

Figure 8-7

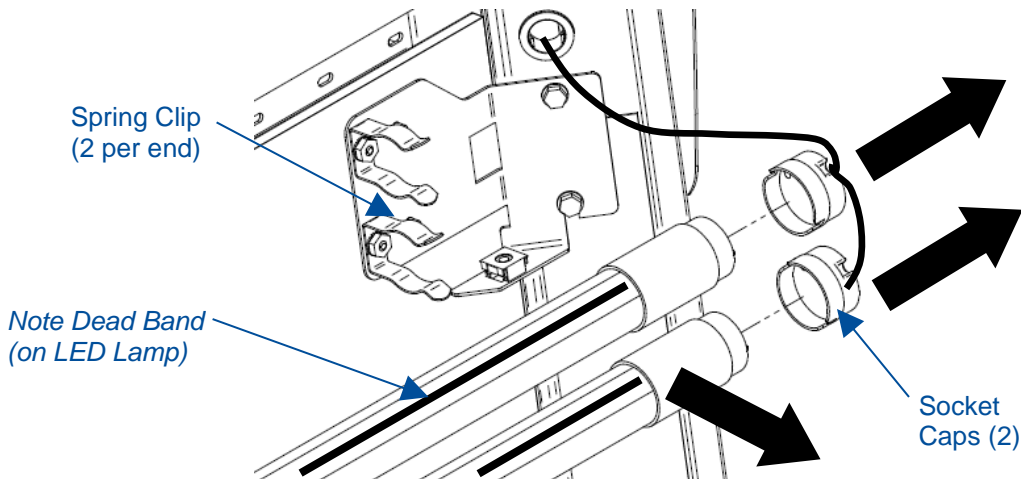

4. Pull each LED Lamp straight toward you to release the lamp from the two Spring Clips holding it in place (Figure 8-7). Note the rotational position of the old LED lamps (there is a dead band stripe that will need to be oriented the same when reinstalling the new LED Lamps).
5. Install the new LED Lamps by reversing the removal procedure. Take care to look at both ends of the new LED Lamps. One end is labeled with a '+' & '-' and 'L' & 'N' (Figure 8-8). This end of the new LED Lamp must go to the right, and is inserted into the Socket Cap.

Figure 8-8

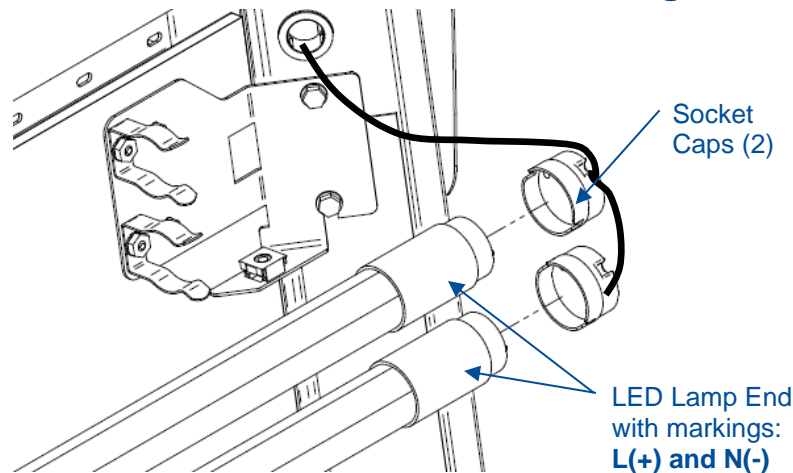

6. When reinstalling the Left End Cap, the pins on each LED Lamp must align rotationally with the Left End Cap. This ensures the dead band stripe is positioned correctly for maximum cabinet lighting.

Changing the Optional UV Lamp

The UV Lamp is an optional feature and may not be found on all models.



THE UV LAMP IN THIS PRODUCT CONTAINS MERCURY

Manage in accordance with local disposal laws. DO NOT place lamps in trash. Dispose as a hazardous waste. For information regarding safe handling, recycling and disposal, consult www.lamprecycle.org

CETTE LAMPE (UV) DANS CE PRODUIT CONTIENT DU MERCURE

Éliminez ou recyclez conformément aux lois applicables. Pour de l'information concernant des pratiques de manipulation sécuritaires et l'élimination sécuritaire et le recyclage, veuillez consulter www.lamprecycle.org



For optimum performance, the UV lamp should be changed as indicated by the UV lamp hour meter.



The UV lamp and the work area of the cabinet must be thoroughly decontaminated before removing the lamp.

1. Start the cabinet blower and let it operate for 5 minutes.
2. Raise the sash to its full open position.
3. Thoroughly surface decontaminate the UV lamp and the work area of the cabinet.
4. Unplug the cabinet or turn off the System Reset Switch, located on the top of the cabinet.
5. Remove the UV lamp by rotating it 90 degrees and pulling it straight towards you and out of its sockets.
6. Install new lamp by reversing the removal procedure.

Towel Catch Removal

To remove the Towel Catch and Pre-Filters for periodic cleaning/replacement, follow these steps.



The Towel Catch, Pre-Filters and the work area of the cabinet must be thoroughly decontaminated before removing the Towel Catch or Pre-Filters.

1. Remove the work surface as described above. The work surface **MUST** be removed before the towel catch will be freed for removal.

2. Remove the towel catch by pivoting the bottom out toward you, as shown in Figure 8-9; it is spring loaded, and you will feel some resistance. Note the orientation of the towel catch during removal.
3. Surface decontaminate the towel catch before removing it completely from the biosafety cabinet.
4. If equipped with pre-filters, inspect them. Disinfect, clean or replace as necessary. Surface decontaminate the pre-filter(s) before removing them completely from the biosafety cabinet.
5. Reinstall the towel catch by sliding it back into position, ensuring that the DOP Sampling Line (the clear tube with an orange cap) either passes through a hole in the towel catch, or rests behind the towel catch, allowing the towel catch to contact the rear wall of the cabinet.

Figure 8-9

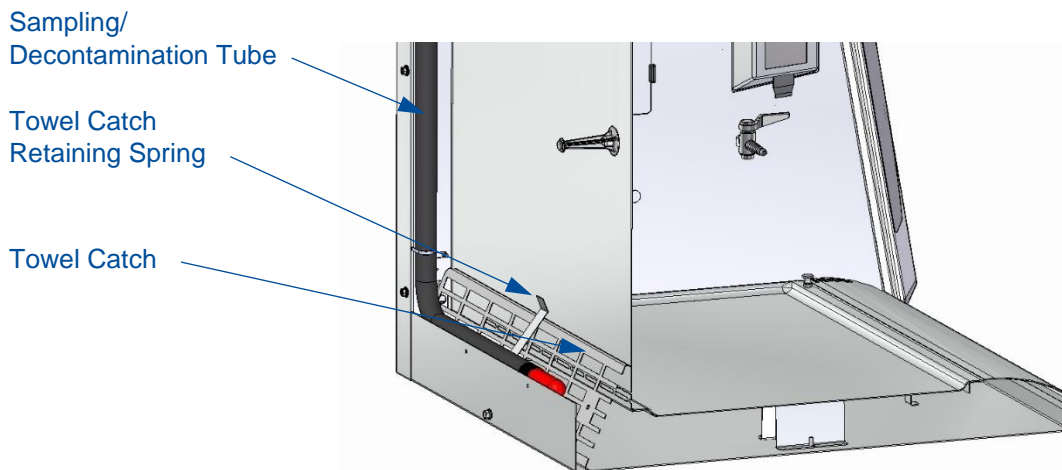

Note: Upper and lower towel catch flanges point to the front of the cabinet, and the bottom of the towel catch rests against the back wall.

Storage

If the cabinet is to be left unused for more than one month, it should be prepared for storage. Follow the instructions below.



The cabinet should not be stored in areas of excess humidity or temperature extremes (see *Environmental Conditions* in [Appendix C](#) for more details). If the cabinet is moved during storage, it must be recertified before use.

1. Close the sash completely and seal the bottom edge with plastic sheeting.

2. Seal the exhaust outlet with plastic sheeting.
3. Unplug the cabinet.
4. Ensure that the cabinet will not be moved or disturbed while being stored.

9: Accessories

This section details the available field-installable accessories and approved modifications for your Cell Logic Type B2 biosafety cabinet.

IV Bar

The IV Bar can be field installed on any size Cell Logic B2 biosafety cabinet. The bar allows for easy hanging of IV bags used inside the biosafety cabinet. Catalog numbers are listed in Table 9-1 below.

Table 9-1

Cabinet Width (Feet)	Catalog Number
4'	3288901
6'	3288903

Stand-Still™ Isolation Platform

Required for supporting microscopes on Cell Logic models with Scope-Ready package. The Stand-Still Isolation Platform promotes proper airflow through the cabinet and underneath the microscope, and reduces vibrations threefold.

Table 9-2

Description	Catalog Number
Stand-Still Platform, 12.0" x 18.75" (30.5 x 47.6 cm)	4028200
XL Stand-Still Platform, 14.0" x 22.75" (35.6 x 57.8 cm)	4028100*

*Requires use of Pure-Vu XL Seal 4027810 or 4027811

Telescoping Base Stands (Non-Welded)

These stands are included with some product models, or available separately. The base stand catalog numbers are listed in Table 9-3 below. An optional caster wheel kit is available for converting leveling feet to casters (catalog number 5190100).

Table 9-3

Cabinet Width (Feet)	Base Stand with Leveling Feet	Base Stand with Casters
4'	5171400	5171410
6'	5171600	5171610

Telescoping Base Stands (Welded)

These stands are fully welded. The base stand catalog numbers are listed in Table 9-4 below. An optional caster wheel kit is available for converting leveling feet to casters (catalog number 5190100).

Table 9-4

Cabinet Width (Feet)	Base Stand with Leveling Feet	Base Stand with Casters
4'	5173400	5173410
6'	5173600	5173610

Electric Hydraulic Lift Base Stands (with Leveling Feet)

These base stands offer infinitely adjustable height between 27.7 and 39.4 inches (702 – 1000 mm), providing a biosafety cabinet work surface height of 30.5 to 42.2 inches (775 – 1071 mm). The height is adjusted by an electric pump that drives the hydraulic legs of the stand. The hydraulic stands are equipped with fixed leveling feet. Catalog numbers are listed in Table 9-5 below.

Table 9-5

Cabinet Width (Feet)	Stand (115v)	Stand (230v)				
		North America	North America	Europe (Schuko)	China / Australia	UK
4'	5180400	5180410	5180430	5180440	5180450	5180470
6'	5180600	5180610	5180630	5180640	5180650	5180670



Note – Make sure service and exhaust connections to the product are properly prepared to allow for the raising or lowering of the product with these stands.

Electric Hydraulic Lift Base Stands (with Casters)

These base stands offer infinitely adjustable height between 28.2 and 39.9 inches (715 – 1012 mm), providing a biosafety cabinet work surface height of 31.0 to 42.7 inches (787– 1084 mm). The height is adjusted by an electric pump that drives the hydraulic legs of the stand. The hydraulic stands are equipped with locking casters. Catalog numbers are listed in Table 9-6 below.

Table 9-6

Cabinet Width (Feet)	Stand (115v)	Stand (230v)				
		North America	North America	Europe (Schuko)	China / Australia	UK
4'	5181400	5181410	5181430	5181440	5181450	5181470
6'	5181600	5181610	5181630	5181640	5181650	5181670



Note – Make sure service and exhaust connections to the product are properly prepared to allow for the raising or lowering of the product with these stands.

Pure-VU™ Seals

Each Cell Logic with Scope-Ready package comes with two clear blank seals one standard height seal (Catalog Number 4027800) and one XL height seal (Catalog Number 4027810). The Punch Kit (4027801) is also included with each Cell Logic with Scope-Ready package. Additional pre-punched seals are listed below:

Table 9-7

Nominal Eyepiece Height	Catalog Number
13.0" (33.0 cm)	4027813
14.0" (35.6 cm)	4027814
15.0" (38.1 cm)	4027815
16.0" (40.6 cm)	4027816
17.0" (43.2 cm)	4027817
16.0" +/- 2.0" (40.6 cm +/- 5.1 cm)*	4027811*

*Pure-Vu XL Seal with pre-punched optics holes

For additional accessories, check Labconco.com or reference the latest version of the Logic Brochure.

10: Troubleshooting

This section details common troubleshooting for your biosafety cabinet.

Blower and Lights not working

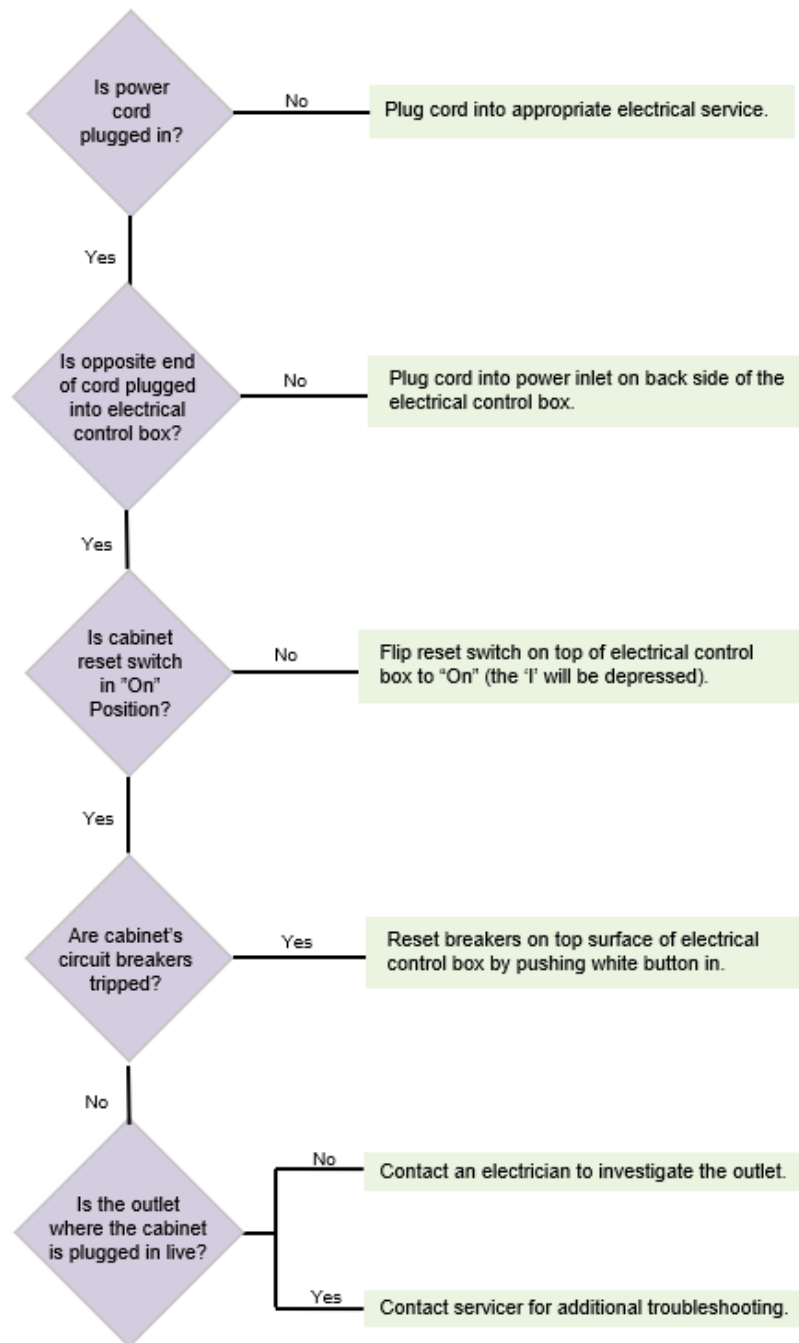

Blower only will not start

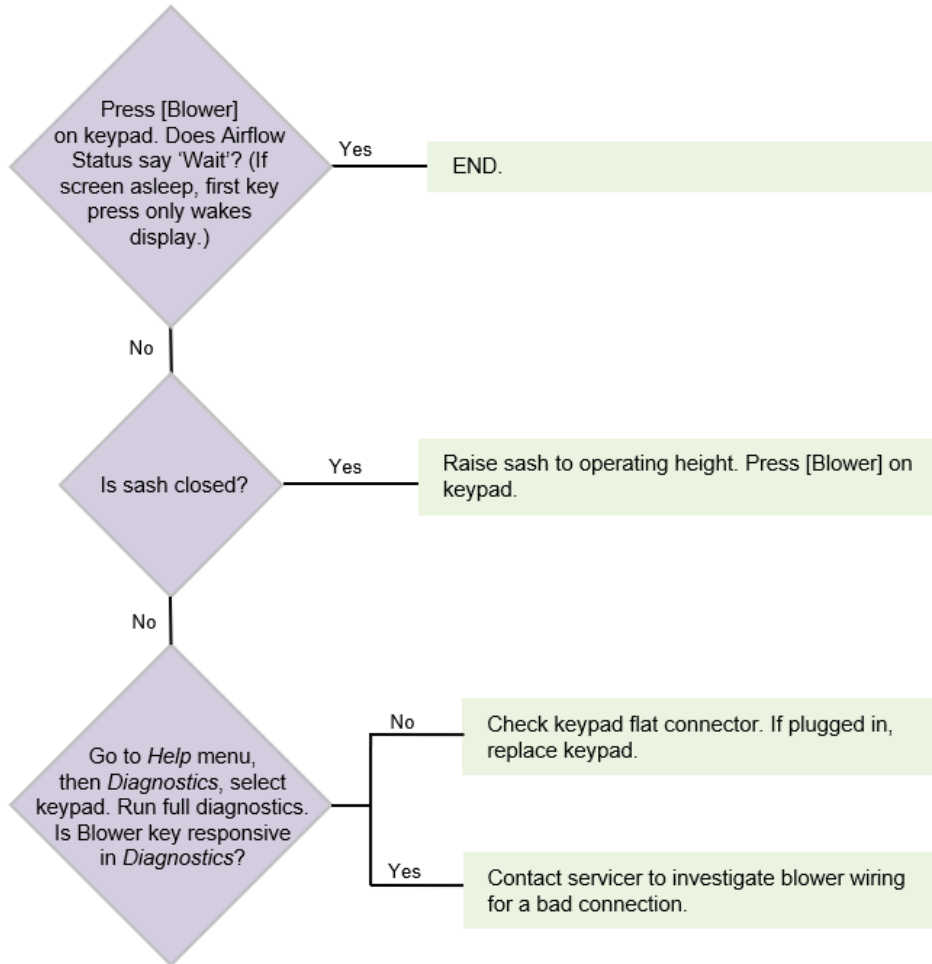

Lights only will not illuminate

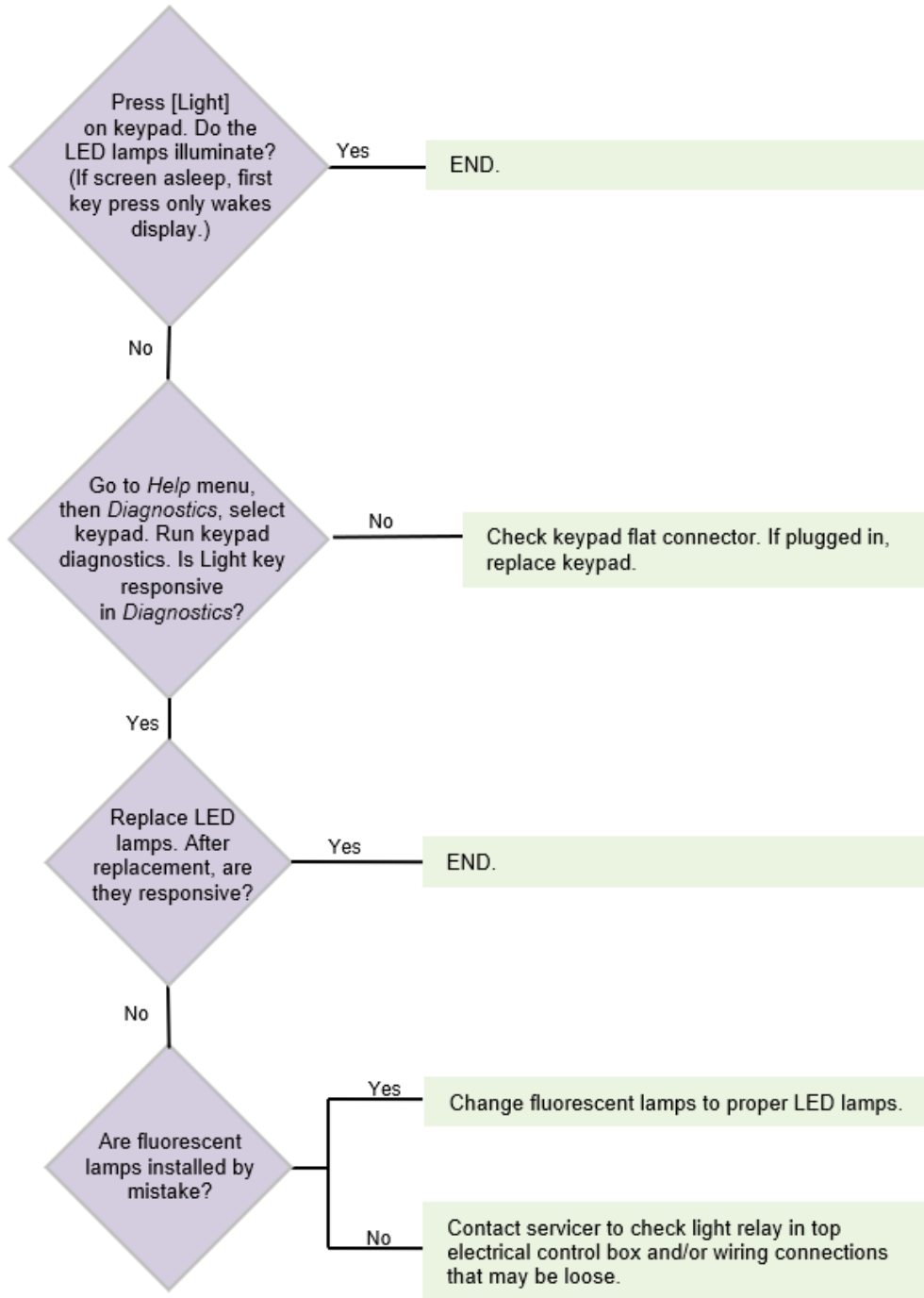

UV Light will not illuminate

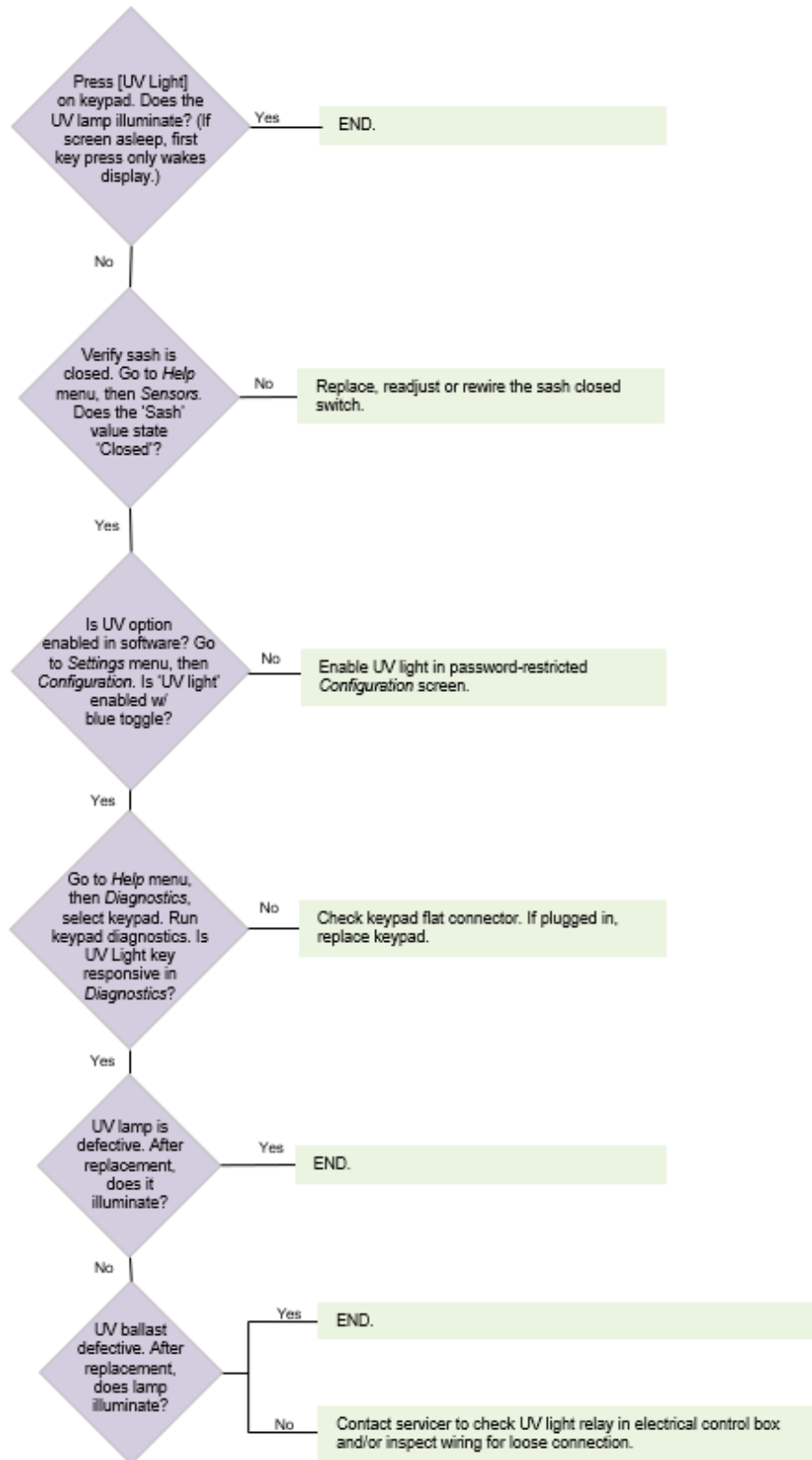

Airflow Alert activating

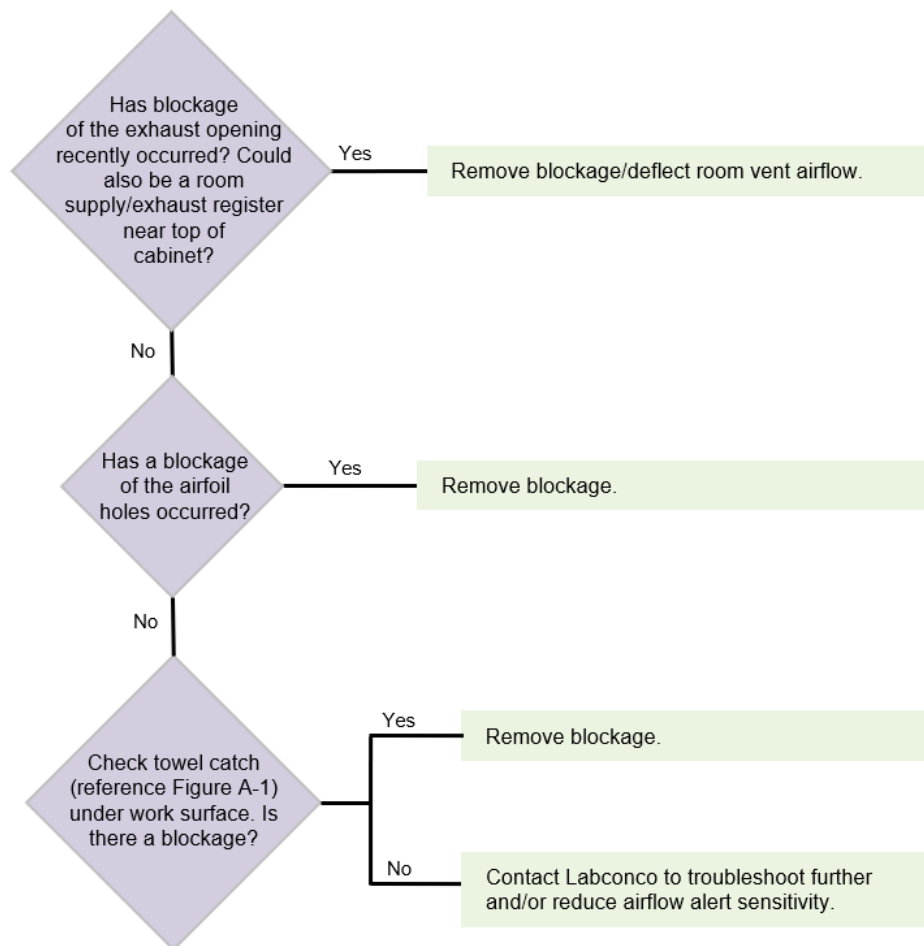

Filter Life Gauge not at 100% when new

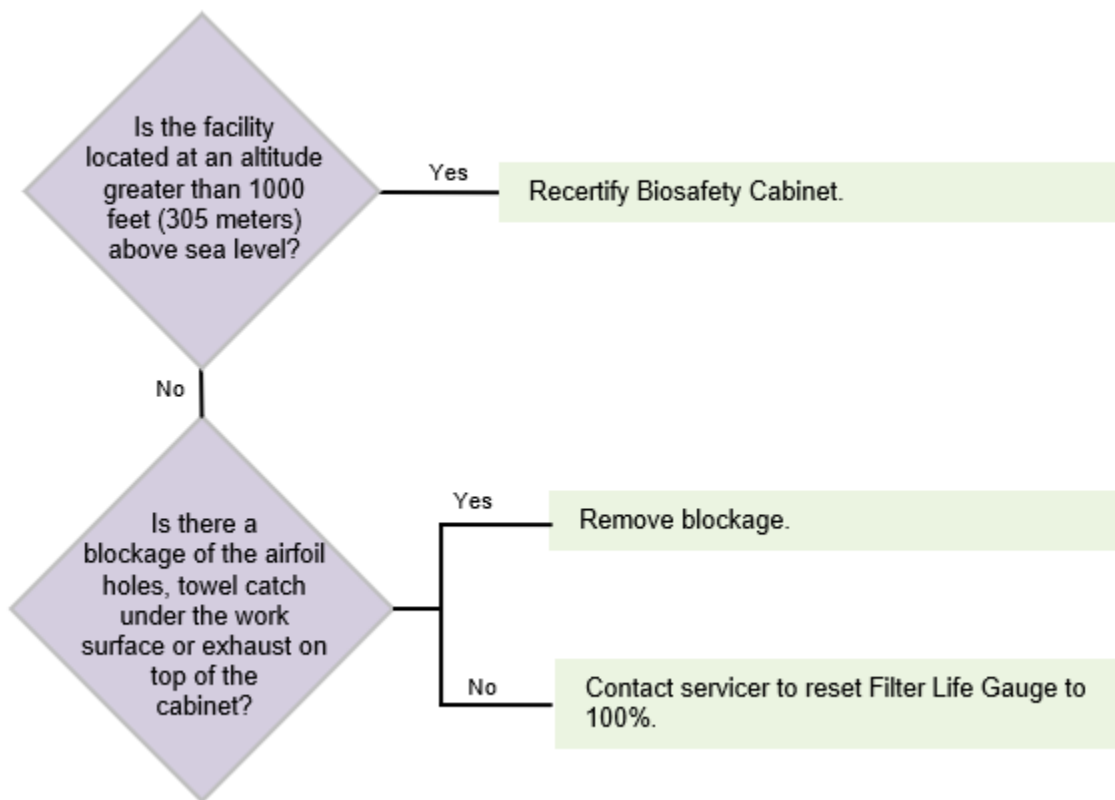

Contamination in the work area

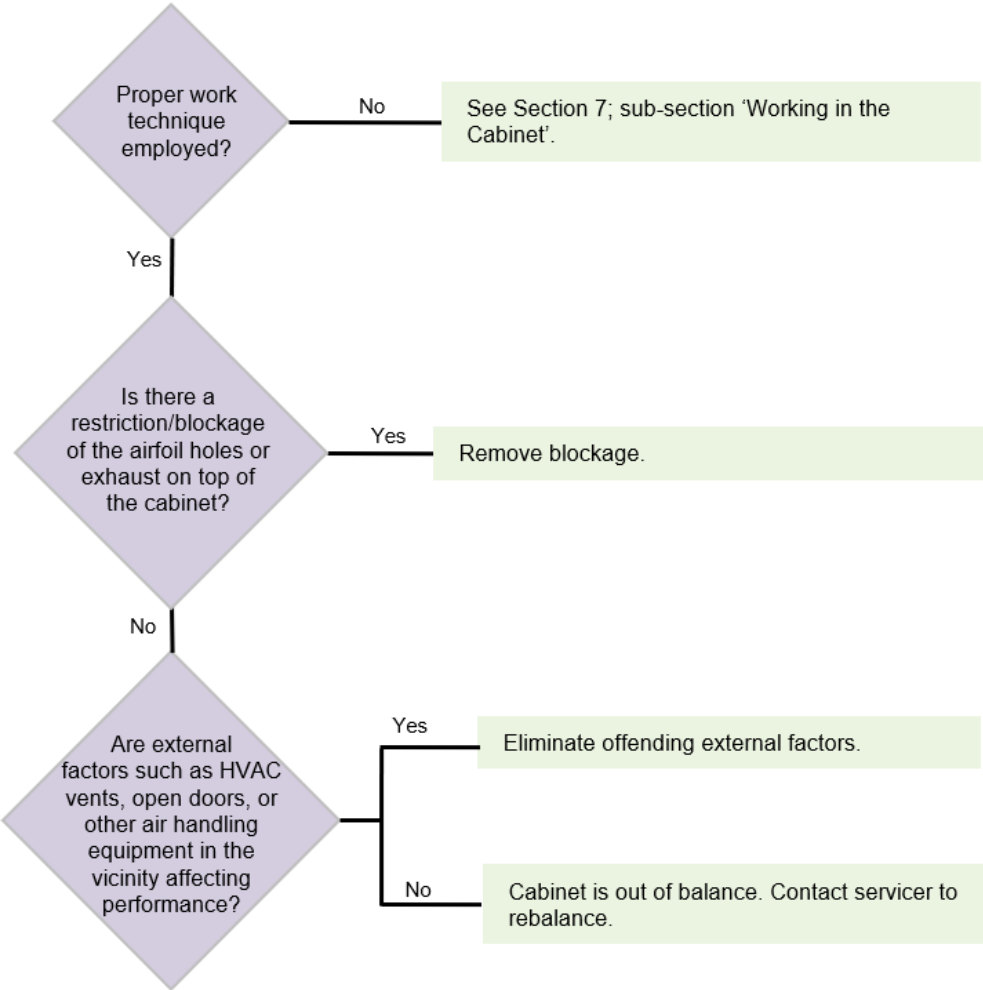

Exhaust Alarm activates 60 seconds after turning blower ON

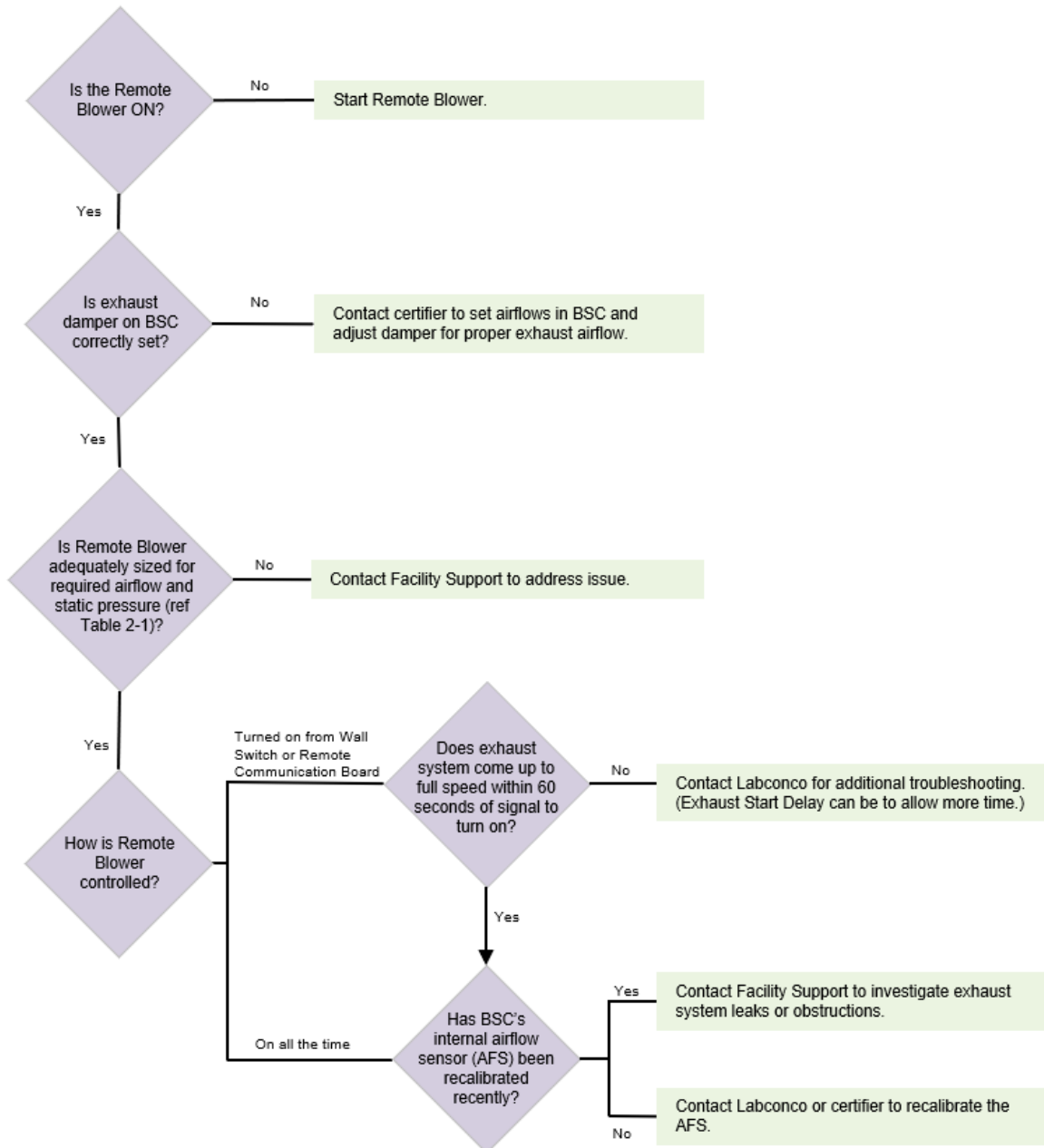

Appendix A: Parts List

Table A-1 and Figure A-1 indicate the location and catalog numbers for the following service, and replacement accessory components.

Table A-1

Item	Quantity Required	Catalog Number	Description
1	1	3838501	Exhaust HEPA Filter 4 Foot Model
	1	3838503	Exhaust HEPA Filter 6 Foot Model
2	1	3838411	Supply HEPA Filter 4 Foot Model
	1	3838413	Supply HEPA Filter 6 Foot Model
3	2	1297504	Lamp, LED, 4 Foot Model
	2	1297506	Lamp, LED, 6 Foot Model
4	1	1271300	Lamp, UV (models with UV light only)
5	1	3850500	Prefilter for 4 Foot B2 Model
	1	3850501	Prefilter for 6 Foot B2 Model



This product uses only LED direct drive lighting. Do NOT install fluorescent bulbs.

Figure A-1

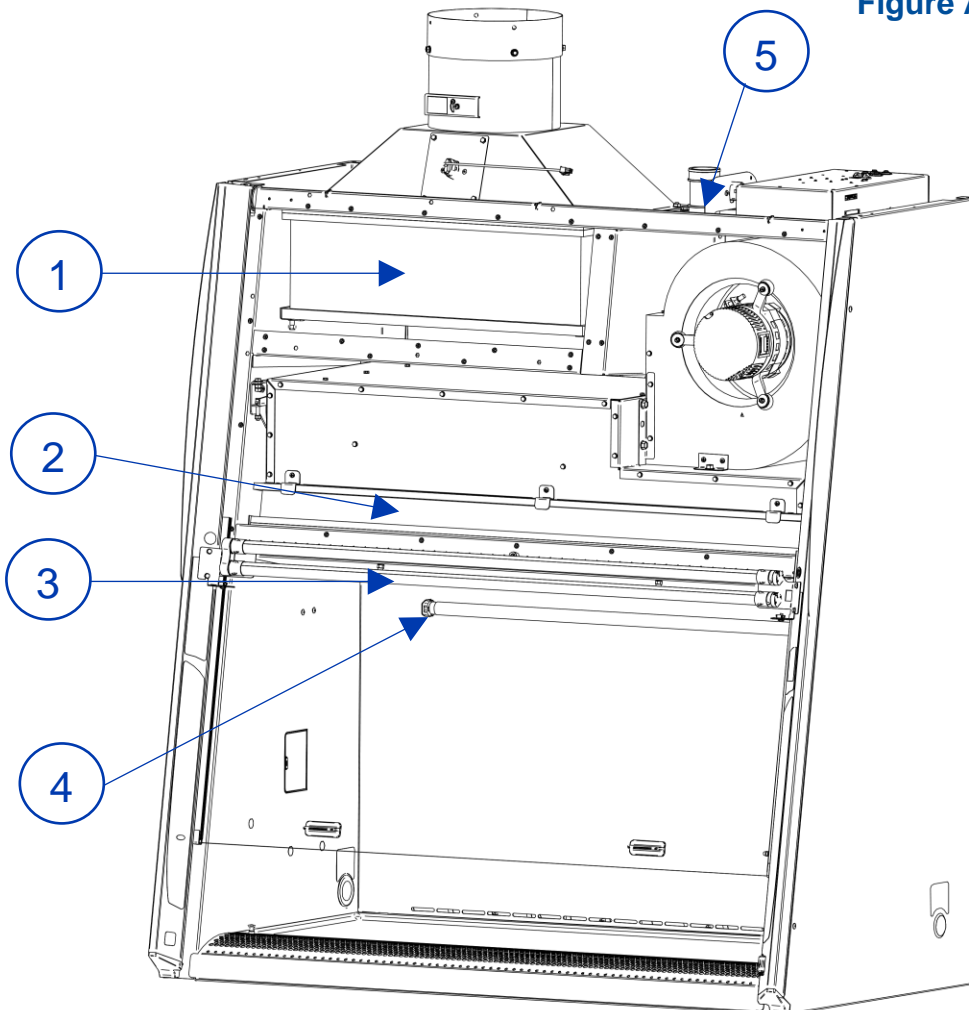

Appendix B: Dimensions

Table B-1 and Figure B-1 indicate the product dimensions. All dimensions shown in inches (centimeters).

Table B-1

Width	A	B	C	Width	A	B	C
4'	48.5 (123.2)	54.4 (138.2)	17.2 (50.5)	6'	72.5 (184.2)	78.4 (199.1)	28.2 (83.6)

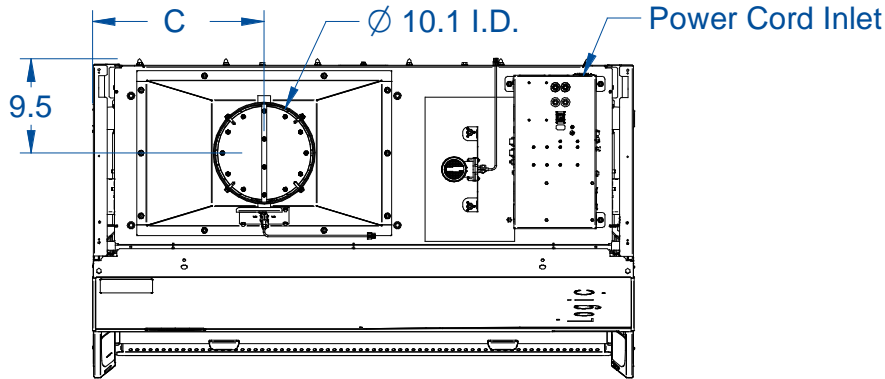
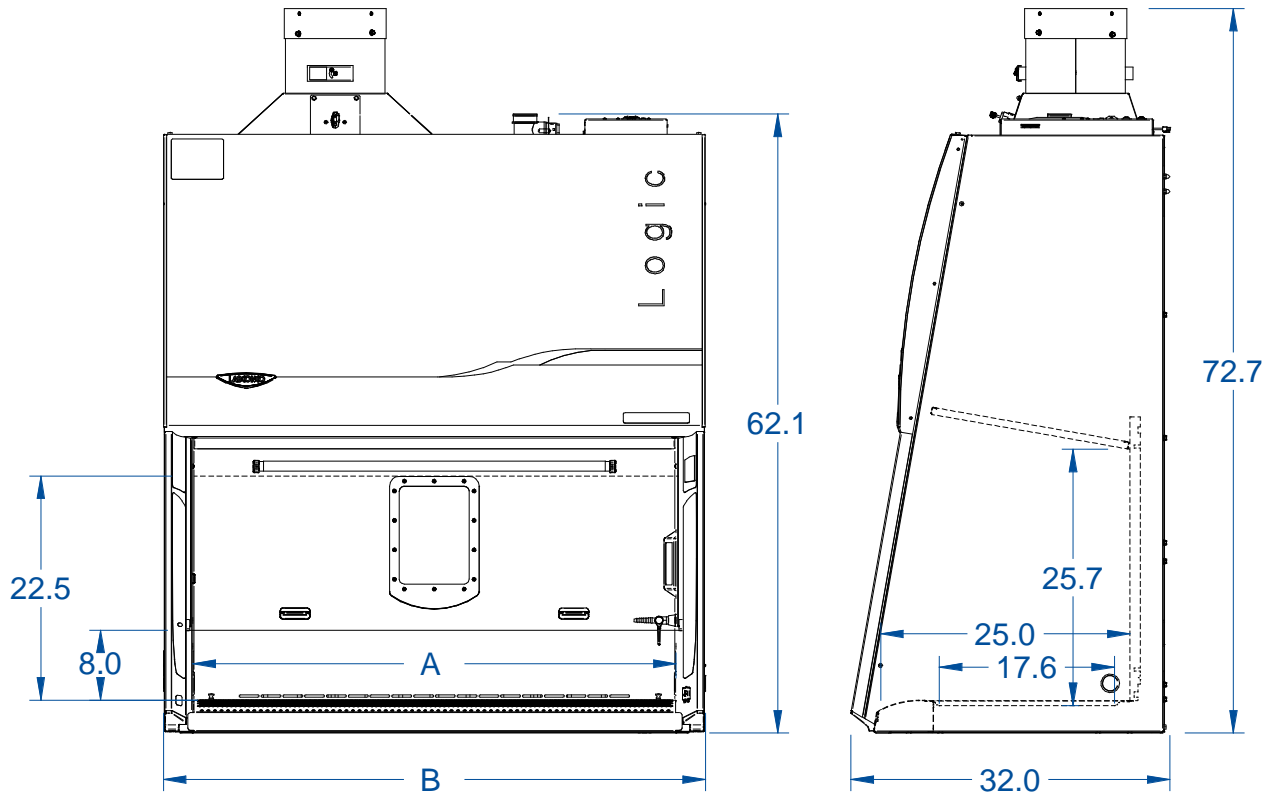

Figure B-1



Appendix C: Specifications

Power Data

Table C-1

Width	Catalog Number	Normal Operating Power (Watts) ¹
4'	3x348xxx2	105 W
6'	3x368xxx2	360 W

¹ Values are for new product with clean filters (light and blower on), and may vary +/- 10%

Motor Specifications

Table C-2

Product Size	Electrical Requirements
All Cabinets, all Voltages	1/2 H.P. Electronically Commutated Motor (ECM) 120-277 VAC – 50/60 Hz, Full Torque – 42 Oz.-Ft (3.56 N-M) 7.7 Full Load Amps @115VAC 4.3 Full Load Amps @230VAC Automatic Thermal Protection

Environmental Conditions

- Indoor use only
- Ambient temperature range: 41° to 104°F (5° to 40°C)
- Maximum relative humidity: 80% for temperatures up to 88°F (31°C), decreasing linearly to 50% relative humidity at 104°F (40°C)
- Main supply voltage fluctuations not to exceed $\pm 10\%$ of the nominal voltage
- Transient overvoltages according to Installation Categories II (Overvoltage Categories per IEC 1010). Temporary voltage spikes on the AC input line that may be as high as 1500V for 115V models and 2500V for 230V models are allowed
- Used in an environment of Pollution degrees 2 (i.e., where normally only non-conductive atmospheres are present). Occasionally, however, a temporary conductivity caused by condensation must be expected, in accordance with IEC 664
- Maximum installation altitude: 10,000 ft (3,048 meters)

Appendix D: Quick Chart Reference

Table D-1

Model	3x348_	3x368_
Type	B2	B2
Cabinet Size (Feet)	4'	6'
Sash Opening (Inches)	8	8
Starting Serial Number ¹	2408_	2408
Nominal Avg. Downflow (FPM)	55 +/-5	55 +/-5
Nominal Average Inflow (FPM)	105 +/-5	105 +/-5
Supply HEPA Data		
Labconco Catalog Number	3838411	3838413
Exhaust HEPA Data		
Labconco Catalog Number	3838501	3838503
Concurrent Balance Values²		
Traverse Exhaust Volume (CFM)	818	1382
Differential Pressure (Inches H ₂ O)	1.8	2.5
Motor/Blower Data (2 ea)³		
Motor HP	1/2	1/2
LED Lamp/UV Lamp Data		
LED Lamps (2 each) ⁴	KT-LED 15T8-48GC-840-D	KT-LED 32T8-72GC-840-D
Color (°K)	4000	4000
Lumens	1850	3200
Glass Type	Frosted	Frosted
UV Lamp	G30T8	G30T8

1. The primary serial tag is on the lower right edge of the front dress panel. The secondary serial tag is located on the Rear of the electronics module on the top right side of the cabinet. The first two digits of the serial number are the year of production; the next two are the month. The next 5 digits are the sequence of production, and the letter following the serial number is the revision level of the cabinet.
2. These values equal the Concurrent Balance Values (CVB) published by National Sanitation Foundation International (NSF International).
3. Each motor must be programmed by Labconco for the appropriate width cabinet.
4. THIS PRODUCT USES DIRECT DRIVE T8 LED LAMPS INSTEAD OF FLUORESCENT LAMPS. THERE IS NO BALLAST; LINE VOLTAGE IS SUPPLIED TO THE LAMP SOCKETS.



This product uses only LED direct drive lighting. Do NOT install fluorescent bulbs.

Appendix E: Installation Guide: Pure-Vu™ Seal and Stand-Still™ Isolation Platforms

For proper installation of the Pure-Vu™ Seal and Stand-Still™ Isolation Platforms on the Cell Logic biosafety cabinet with Scope-Ready™ Package, reference the following figures and instructions.

Figure E-1 also shows the proper placement of the Stand-Still Isolation Platform.

Figure E-1



Figure E-2 is an aid to show the Pure-Vu Seal fully installed with the eyepieces extended and sealed. Figure E-2 also shows the microscope moved forward into proper position on the Stand-Still Isolation Platform.

Figure E-2



Stereoscopes with forward extending bases and frequent eyepiece height adjustment typically require the selection of a Pure-Vu XL Seal and Stand-Still XL Isolation Platform. Figures E-3 through E-10 are an aid in setting up the pleated Pure-Vu XL Seal. Figures E-11 and E-12 show typical complete installations of stereo microscopes and proper placement of the Stand-Still XL Isolation Platform. Listed next are instructions for setting up the pleated design of the Pure-Vu XL Seal.

1. Per Figure E-3, with the outer aerodynamic collar removed, place the Pure-Vu XL Seal over the inner aerodynamic mounting collar. Locate the top five holes and secure with transparent tape as shown. Pure-Vu XL Seals allow for eyepiece height flexibility of +/- 2.0" (51 mm).

Figure E-3



2. Per Figure E-4, form the first pleat and secure with transparent tape. The seal shown has pre-cut eyepiece holes (Catalog Number 4027811) and is designed for the upper portion of the glass cutout. This upper portion of the glass cutout is used frequently with stereoscopes. However, should you need a pleat at the middle or lower position of the glass cutout, then the pleat can be moved lower when setting up the Blank Pure-Vu XL Seal (Catalog Number 4027810).

Figure E-4

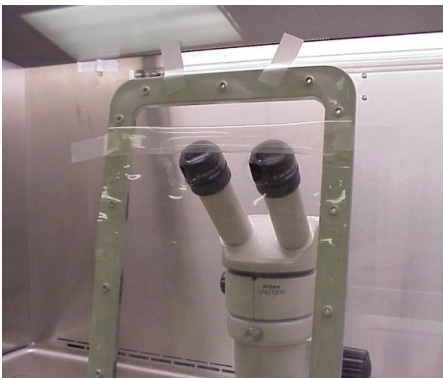

3. Per Figure E-5, form the second pleat and secure with transparent tape.

Figure E-5



4. Per Figure E-6 and Figure 4-8, place the Outer Aerodynamic collar over the Pure-Vu XL Seal and lightly secure in place with the 14 Phillips mounting screws. Do not tighten.

Figure E-6



5. Per Figure E-7, remove the transparent tape and then tighten the 14 Phillips mounting screws.

Figure E-7



6. Per Figure E-8, move the microscope forward through the holes in the Pure-Vu Seal and install each eyepiece. A tight seal should be formed around each eyepiece.

Figure E-8



7. Figure E-9 shows the finished installation.

Figure E-9



8. Per Figure E-10, adjust the scope eyepiece height for proper focus.

Figure E-10

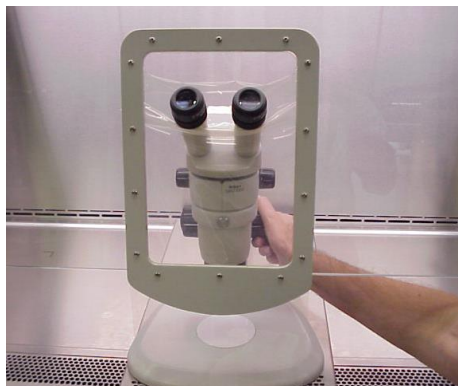

9. Figure E-11 shows the completed installation of the Pure-Vu XL Seal and Stand-Still XL Isolation Platform for one scope manufacturer. The Pure-Vu XL Seals extend 5.5" below the aerodynamic collar.

Figure E-11



10. Figure E-12 shows a different installation of the Pure-Vu XL Seal and Stand-Still XL Isolation Platform for another scope manufacturer.

Figure E-12



11. Refer to [Section 9: Accessories](#) to order Pure-Vu Seals and Stand-Still Isolation Platforms and use [Section 4](#) and [Appendix E](#) as an aid for proper setup.

Pure-Vu™ Template

For the optics cutout locations on various pre-cut Pure-Vu Seals by Catalog Number, see Figure E-13.

Note: Not to scale, see Figure E-14 for a 1:1 scale drawing of these optics hole locations. The 1:1 scale drawing allows you to cut out the desired optics holes in the provided blank Pure-Vu Seal.

Figure E-13

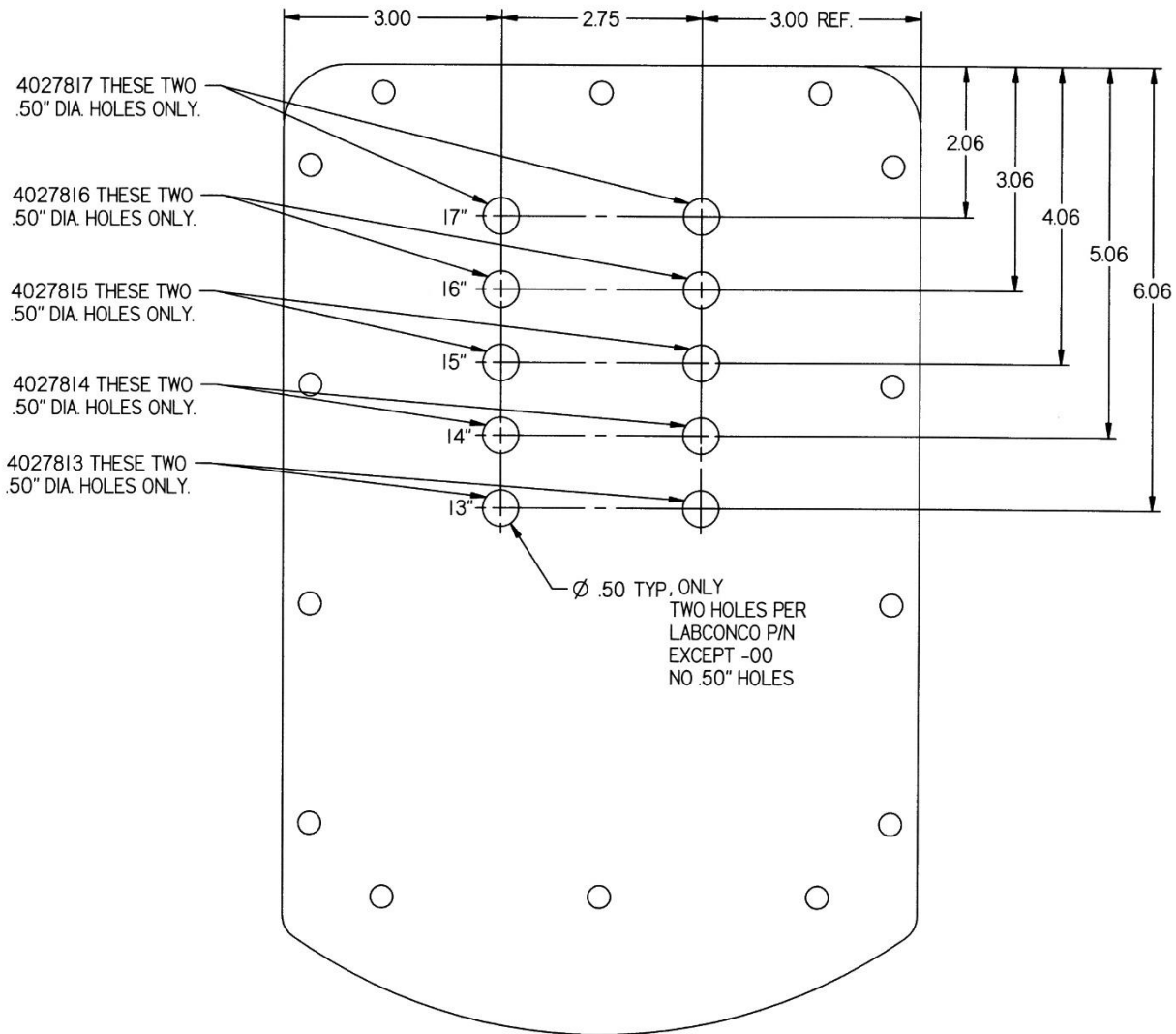
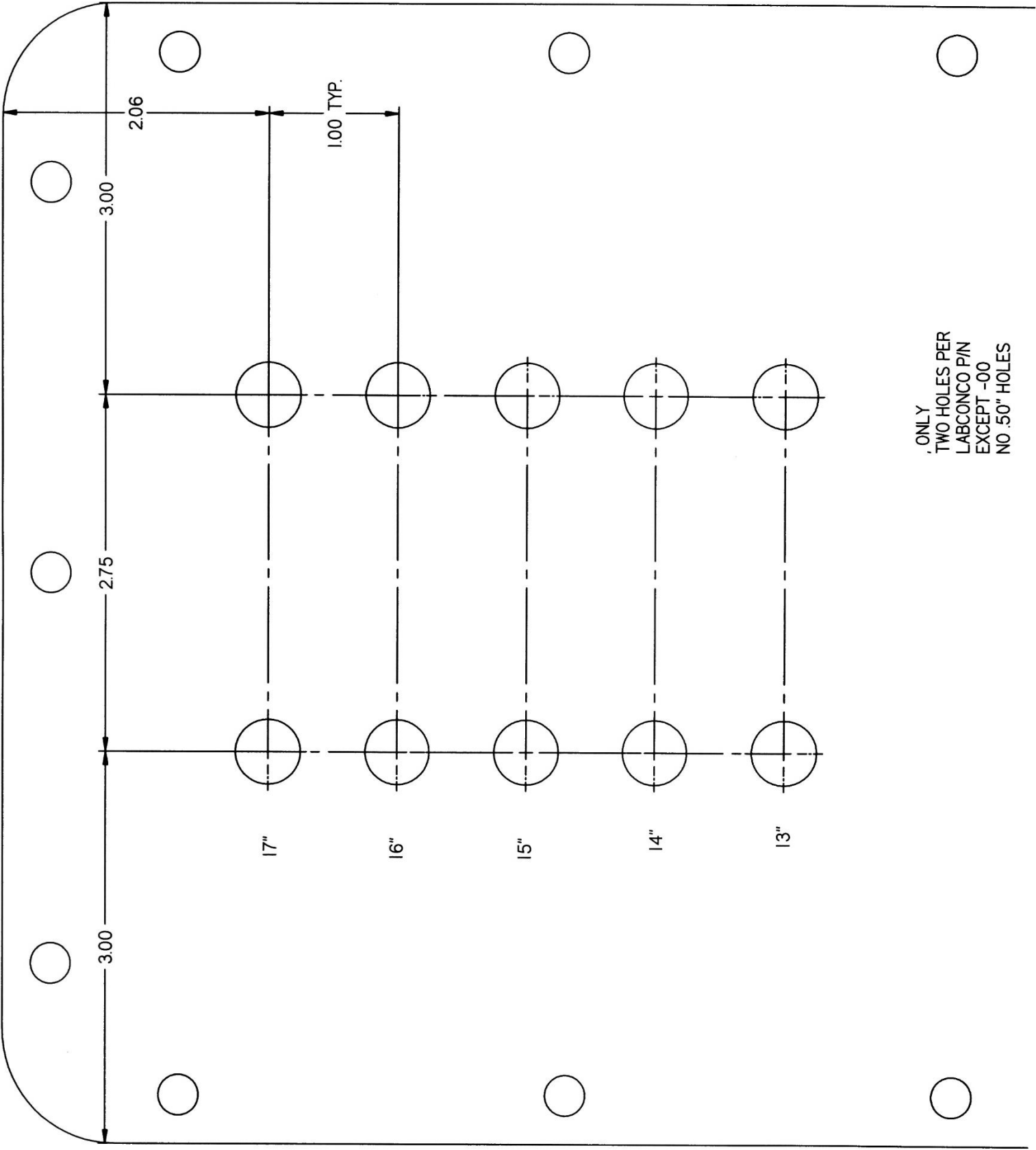

Figure E-14



ONLY
TWO HOLES PER
LABCONCO P/N
EXCEPT -00
NO .50" HOLES